

|      |              |      |
|------|--------------|------|
| MAPX | MODIFICATION | DATE |
|------|--------------|------|

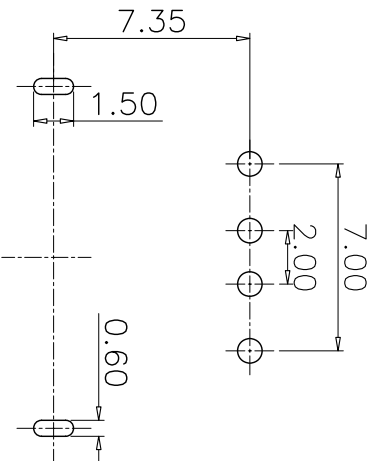

PCB HOLES(THE PATTERN SIDE)  
NOTE:GENERAL TOLERANCE:±0.1mm

- NOTES:
- HOUSING: SEE NOTES, TERMINAL: SEE NOTES, SHELL: SEE NOTES.
- SPECIFICATION:
- ELECTRICAL CHARACTERISTIC:
    - CONTACT RESISTANCE: 30MΩ MAX
    - DIELECTRIC WITHSTANDING VOLTAGE: 500V AC FOR 1MIN
    - INSULATION RESISTANCE: 1000MΩ MIN
  - MECHANICAL CHARACTERISTIC:
    - INSERTION FORCE: 35N(3.57KGF) MAX
    - EXTRACTION FORCE: 10~35N(1.02~3.57KGF) MIN
    - DURABILITY: 1500 CYCLES EXTRACTION FORCE:10~35N 5000 CYCLES MIN
    - 5000 CYCLES EXTRACTION FORCE:3~35N
  - ENVIRONMENTAL:
    - OPERATING TEMPERATURE: -55°C+85°C
  - Contact finish:
    - 01:Selective Gold Flash
    - 02:Selective Gold 3U"
    - 03:Selective Gold 5U"
    - 04:Selective Gold 15U"
    - 05:Selective Gold 30U"

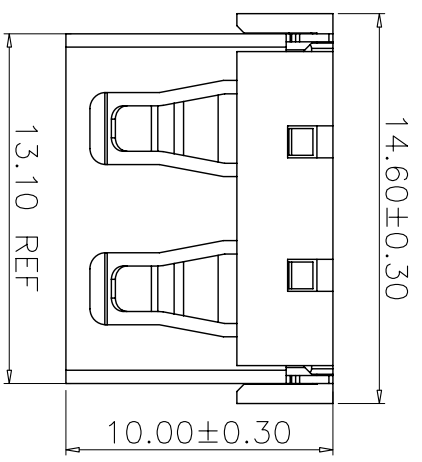
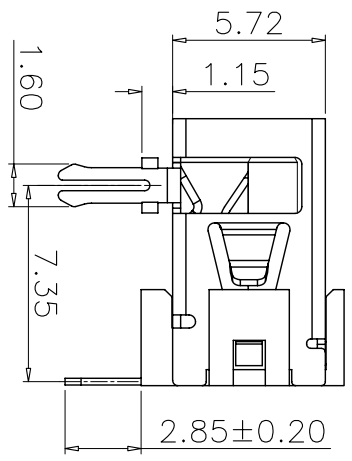
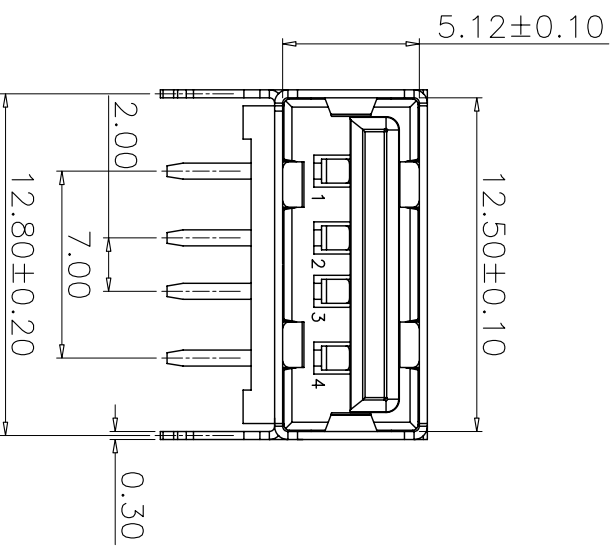

# 深圳市精拓金电子有限公司

|                            |  |            |         |                    |                      |
|----------------------------|--|------------|---------|--------------------|----------------------|
| 产品图                        |  | 制图料号       |         | USB A/F 10.0-B-005 |                      |
| 公差一览表                      |  | UNIT       | DRAWING | Z-Y-B              |                      |
| TOLERANCE UNLESS OTHERWISE |  | MM         | 审核      | 产品名称               | USB A/F 10.0 (前两脚无边) |
| X ±0.15 X ±5.°             |  | 1:1        | 核准      | PRODUCT NO         |                      |
| X ±0.10 X ±2.°             |  | 2010.05.06 | APPD    | 角法                 | 版本                   |
| .XX ±0.05 .XX ±1.°         |  |            |         | VIEW               | VER                  |
| .XXX ±0.03 .XXX ±0.5°      |  |            |         |                    | A0                   |