

MAPX	MODIFICATION	DATE
------	--------------	------

NOTES:
 1. HOUSING: SEE NOTES, UL94V-0.
 TERMINAL: SEE NOTES.
 SHELL: SEE NOTES.
 SPECIFICATION:

1. ELECTRICAL CHARACTERISTIC:
 CONTACT RESISTANCE: 30MΩ MAX
 DIELECTRIC WITHSTANDING VOLTAGE: 500V AC FOR 1MIN
 INSULATION RESISTANCE: 1000MΩ MIN

2. MECHANICAL CHARACTERISTIC:
 INSERTION FORCE: 35N(3.57KGf) MAX
 EXTRACTION FORCE: 10~35N(1.02~3.57KGf)MIN
 DURABILITY: 1500 CYCLES EXTRACTION FORCE: 10~35N
 5000 CYCLES MIN

3. ENVIRONMENTAL:
 OPERATING TEMPERATURE: -55 °C+85 °C

4. Contact finish:
 01: Selective Gold Flash
 02: Selective Gold 3U"
 03: Selective Gold 5U"
 04: Selective Gold 15U"
 05: Selective Gold 30U"

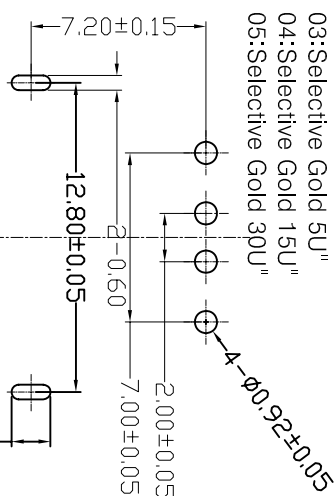

FRONT EDGE OF CONNECTOR
 PCB LAYOUT (T=1.60mm)

深圳市精拓金电子有限公司

PRODUCT CHART DWG		公差一览表		单位		制图		制图料号	
TOLERANCE UNLESS OTHERWISE	±5°	MM	DRAWING	Z-Y-B	PRODUCT PART NO	JTY-USB-10.6-001			
X ±0.25	X ±2°	比例	SCALE	1:1	产品名称	USB A/I 封闭式90度 反向成品			
X ±0.20	X ±1°	日期	DATE	2013.10.24	审核	APRD	版本	VER	AD
XX ±0.15	XX ±0.5°	XXX ±0.10	XXX ±0.5°						