

MAPX	MODIFICATION	DATE

NOTES:
 1. HOUSING: SEE NOTES, TERMINAL: SEE NOTES, SHELL: SEE NOTES.
 SPECIFICATION:

1. ELECTRICAL CHARACTERISTIC:
 CONTACT RESISTANCE: 30MΩ MAX
 DIELECTRIC WITHSTANDING VOLTAGE: 500V AC FOR 1MIN
 INSULATION RESISTANCE: 1000MΩ MIN
 2. MECHANICAL CHARACTERISTIC:
 INSERTION FORCE: 35N(3.57KG) MAX
 EXTRACTION FORCE: 10~35N(1.02~3.57KG) MIN
 DURABILITY: 1500 CYCLES EXTRACTION FORCE: 10~35N
 5000 CYCLES MIN
 5000 CYCLES EXTRACTION FORCE: 3~35N

3. ENVIRONMENTAL:
 OPERATING TEMPERATURE: -55°C+85°C

4. Contact finish:
 01: Selective Gold Flash
 02: Selective Gold 3U"
 03: Selective Gold 5U"
 04: Selective Gold 15U"
 05: Selective Gold 30U"

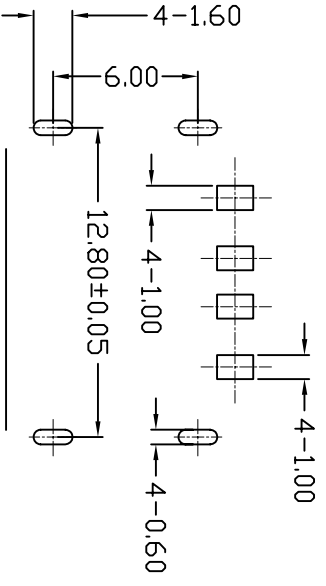

FRONT EDGE OF CONNECTOR
 PCB LAYOUT (T=1.60mm)

深圳市精拓金电子有限公司

公差一览表		制图		制图料号	
TOLERANCE UNLESS OTHERWISE	UNITS	DRAWING	Z-Y-B	PRODUCT PART NO.	JTY-USB-10.6-002
X ±0.15	X	±5°	审核	产品名称	USB A/F 10.6无边四脚鱼叉(方弹)
X ±0.10	X	±2°	审核	PRODUCT NO.	
XX ±0.05	XX	±1°	核准	角法	版本
XXX ±0.03	XXX	±0.5°	核准	角法	版本
DATE	2012.09.24	DATE	核准	角法	版本