

正向10.0全贴/6.50

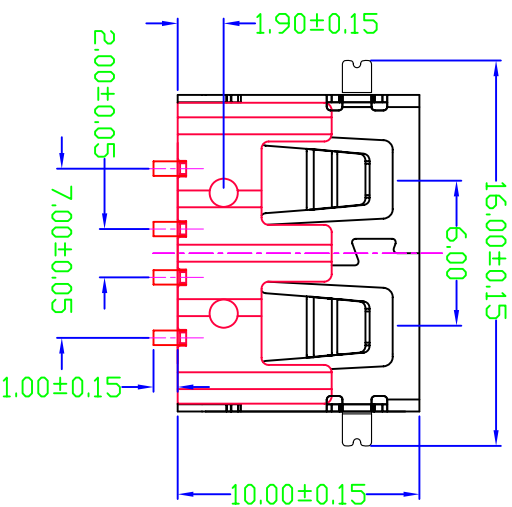

- NOTES:
- 1.HOUSING: SEE NOTES, UL94V-0 .
TERMINAL: SEE NOTES.
SHELL: SEE NOTES.
 - SPECIFICATION:
 - 1.ELECTRICAL CHARACTERISTIC:
CONTACT RESISTANCE: 30MΩ MAX
DIELECTRIC WITHSTANDING VOLTAGE: 500V AC FOR 1MIN
INSULATION RESISTANCE: 1000MΩ MIN
 - 2.MECHANICAL CHARACTERISTIC:
INSERTION FORCE: 35N(3.57KGF) MAX
EXTRACTION FORCE: 10~35N(1.02~3.57KGF)/MIN
DURABILITY: 1500 CYCLES EXTRACTION FORCE:10~35N
5000 CYCLES MIN
 - 3.ENVIRONMENTAL:
OPERATING TEMPERATURE: -55°C+85°C
 - 4.Contact finish:
01: Selective Gold Flash
02: Selective Gold 3U"
03: Selective Gold 5U"
04: Selective Gold 15U"
05: Selective Gold 30U"

FRONT EDGE OF CONNECTOR
PCB LAYOUT

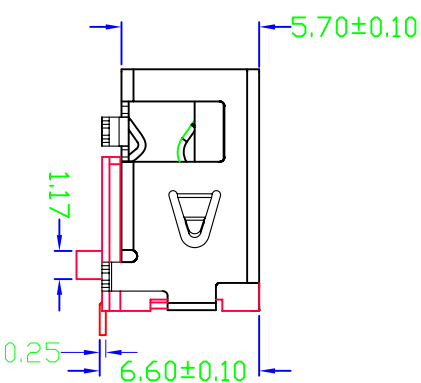
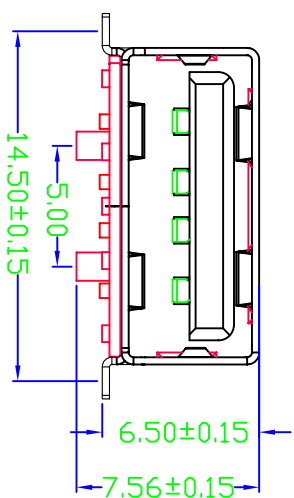
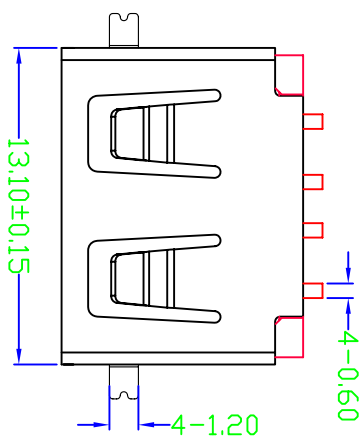
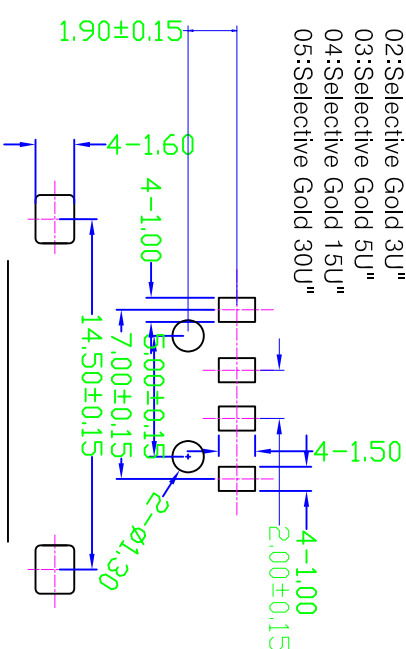

产品图
PRODUCT CHART DWG

深圳市精拓金电子有限公司

公差一览表		单位		制图		制图料号	
TOLERANCE	UNLESS OTHERWISE	UNITS	MM	DRAWING	Z-Y-B	PRODUCT PART NO.	JTY-1(USB-10.0)/SMT-002
X	±0.25	X	±5°	审核		产品名称	USB A/F 10.0无边全贴6.5 (方排)
X	±0.20	X	±2°	CHKD		PRODUCT NO.	
XX	±0.15	XX	±1°	核准		角法	版本
XXX	±0.10	XXX	±0.5°	APPR		VIEW	AD
		日期	2015/04/24				

