

MAPX	MODIFICATION	DATE
------	--------------	------

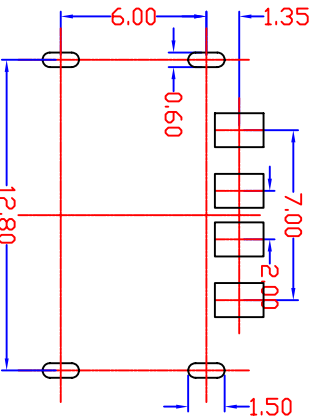
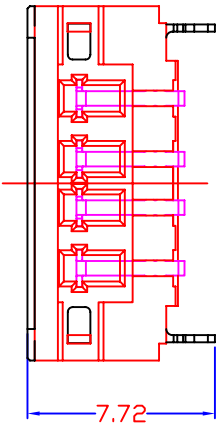
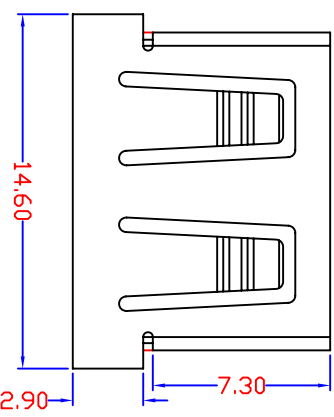
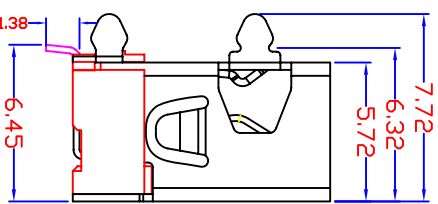
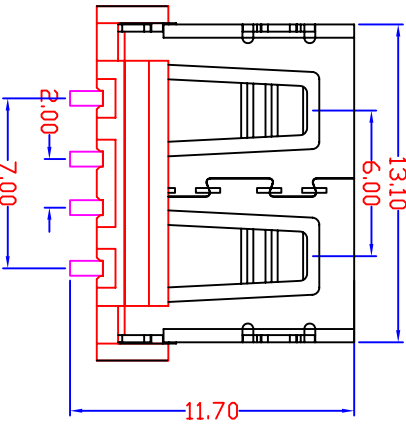
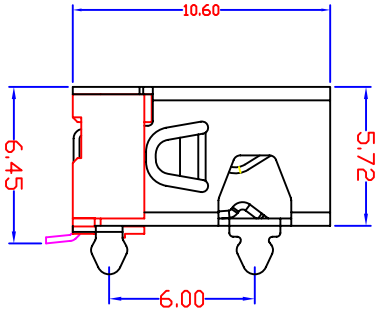
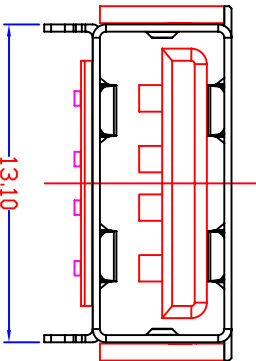

**Specification:**

**1. Electrical Characteristics:**  
 Dielectric Withstanding Voltage: AC 500V/1MINUTE.  
 Insulation Resistance: 1000 MΩ/Min.  
 Contact Resistance: 30 mΩ Max.

**2. Mechanical Characteristics:**  
 INSERTION FORCE: 30N(3.06kgf) MAX  
 EXTRACTION FORCE: 10~30N(1.02~3.06Kgf)  
 Durability: 1500cycles, EXTRACTION FORCE: 10~30N(1.02~3.06Kgf)

**3. Material:**  
 Terminal: Phosphor Bronze, C5191R-H T=0.25  
 Plating: Gold 0.76 um Min plating over 1.27 um Min Nickel underplate, 2.54 um Min Sn selective plating on solder tail;  
 Shell: Phosphor Bronze, C5191R-H T=0.30mm  
 Plating: Nickel underplate 2.54 um Min;  
 Housing: 无卤LCP Black; UL94V-0

**4. Environmental:**  
 Operating Temperature: 0°C to +85°C.

产品图  
PRODUCT CHART DWG

深圳市精拓金电子有限公司

公差一览表		单位	制图	Z-Y-B	制图料号
TOLERANCE UNLESS OTHERWISE	UNITS	MM	DRAWING		PRODUCT PART NO.
X ±0.15	X	±5°	审核	1:1	产品名称
X ±0.10	X	±2°	CHD	DATE	PRODUCT NO.
XX ±0.05	XX	±1°	批准	20110902	USB A/F 90° SWT 短体
XXX ±0.03	XXX	±0.5°	APPD		角法
					版本
					VER
					AD