

## Large Current Positive Voltage Regulators

### ■ GENERAL DESCRIPTION

The XC6203 series are highly precise, low power consumption, 3 terminal positive voltage regulators manufactured using CMOS and laser trimming technologies.

The series provides large currents with a significantly small dropout voltage.

The XC6203P consists of a driver transistor, a current limiter, a precision reference voltage and an error amplifier. The XC6203E is also available but without the current limiter function. Output voltage is selectable in 0.1V increments between a voltage of 1.8V and 6.0V.

SOT-23, SOT-89, SOT-223 package are available.

### ■ APPLICATIONS

- Magnetic disk drive
- Note PCs / Tabet PCs
- Digital still cameras / Camcorders
- Digital audio equipments
- Reference voltage sources
- Multi-function power supplies

### ■ FEATURES

- Maximum Output Current** : 400mA (3.3V)
- Maximum Operating Voltage** : 8.0V
- Output Voltage Range** : 1.8V ~ 6.0V  
(selectable in 0.1V increments)
- Highly Accurate** :  $\pm 2\%$
- Low Power Consumption** :  $8.0 \mu A$  (TYP.)
- Line Regulation** :  $0.2\% / V$  (TYP.)
- Output Voltage Temperature Characteristics**  
:  $\pm 100\text{ppm}/^\circ\text{C}$  (TYP.)
- Dropout Voltage** : 150mV @ 100mA,  
300mV @ 200mA
- Operating Ambient Temperature** :  $-40^\circ\text{C} \sim 85^\circ\text{C}$
- Packages** : SOT-23, SOT-89,  
SOT-223
- Environmentally Friendly** : EU RoHS Compliant, Pb Free

### ■ TYPICAL APPLICATION CIRCUIT

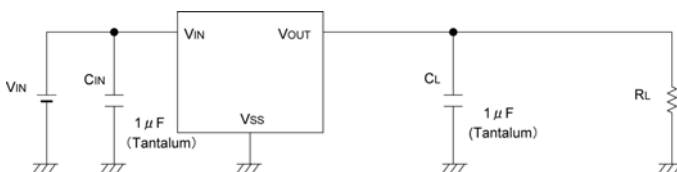

### ■ TYPICAL PERFORMANCE CHARACTERISTICS

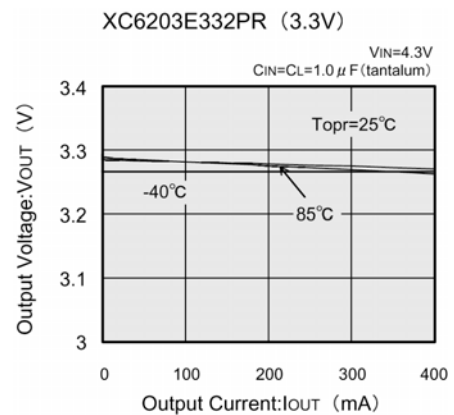

## PIN CONFIGURATION

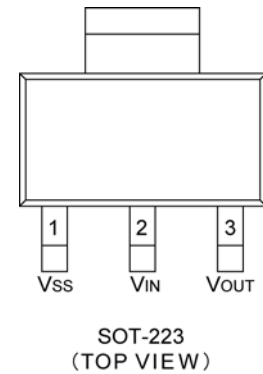
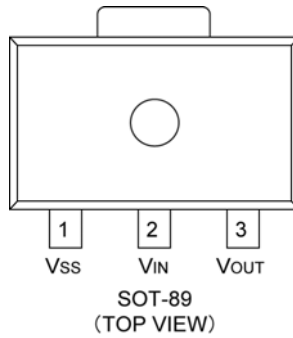
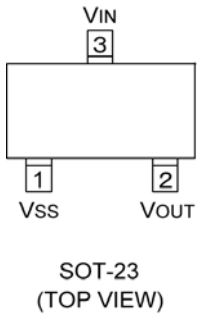

## PIN ASSIGNMENT

PIN NUMBER		PIN NAME	FUNCTIONS
SOT-23	SOT-89/SOT-223		
1	1	VSS	Ground
3	2	VIN	Power Input
2	3	VOUT	Output

## PRODUCT CLASSIFICATION

### Ordering Information

XC6203 ①②③④⑤⑥-⑦<sup>(\*)</sup>

DESIGNATOR	ITEM	SYMBOL	DESCRIPTION
①	Type of Regulator	P	Current limiter circuit built-in
		E	No current limiter circuit built-in
②③	Output Voltage	18~	e.g. 1.8V → ③=1, ④=8
④	Output Accuracy	2	±2% Output voltage is {x.x0V} (the 2 <sup>nd</sup> decimal place is "0")
		A	±2% Output voltage is {x.x5V} (the 2 <sup>nd</sup> decimal place is "5")
⑤⑥-⑦ <sup>(*)</sup>	Packages (Order Unit)	MR	SOT-23 (3,000/Reel)
		MR-G	SOT-23 (3,000/Reel)
		PR	SOT-89 (1,000/Reel)
		PR-G	SOT-89 (1,000/Reel)
		FR	SOT-223 (1,000/Reel)
		FR-G	SOT-223 (1,000/Reel)

<sup>(\*)</sup> The "-G" suffix denotes Halogen and Antimony free as well as being fully EU RoHS compliant.

## ■ BLOCK DIAGRAMS

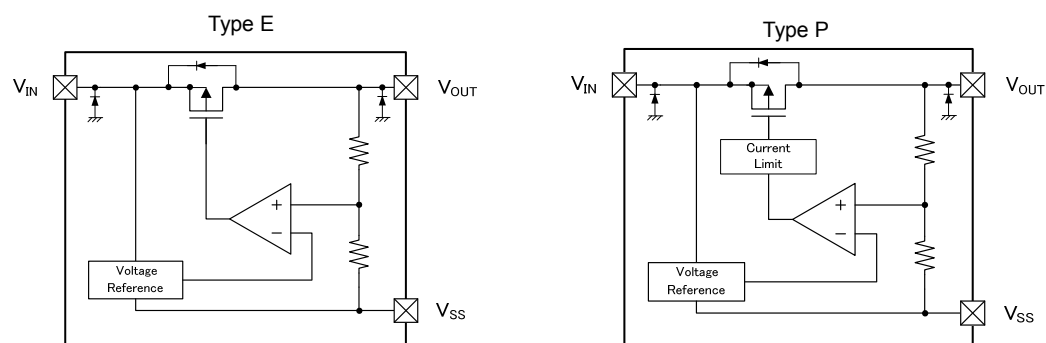

\* Diodes inside the circuits are ESD protection diodes and parasitic diodes.

## ■ ABSOLUTE MAXIMUM RATINGS

$T_a = 25^\circ\text{C}$

PARAMETER	SYMBOL	RATINGS	UNITS	
Input Voltage	$V_{IN}$	-0.3~+12.0	V	
Output Current	$I_{OUT}$	600 <sup>(*1)</sup>	mA	
Output Voltage	$V_{OUT}$	-0.3~ $V_{IN}+0.3$	V	
Power Dissipation	SOT-23	Pd	250	mW
			500(PCB mounted) <sup>(*2)</sup>	
			500	
			1000(PCB mounted) <sup>(*2)</sup>	
			1500(PCB mounted) <sup>(*2)</sup>	
Operating Ambient Temperature	$T_{opr}$	-40~+85	$^\circ\text{C}$	
Storage Temperature	$T_{stg}$	-55~+125	$^\circ\text{C}$	

\*1:  $I_{OUT} \leq Pd / (V_{IN} - V_{OUT})$

\*2 These values are example data which is taken with the PCB mounted. Please refer to pages 20 to 22 for details.

## ELECTRICAL CHARACTERISTICS

XC6203 Series Type E

Ta=25°C

PARAMETER	SYMBOL	CONDITIONS	MIN.	TYP.	MAX.	UNITS	CIRCUIT
Output Voltage	$V_{OUT(E)}$ <sup>(2)</sup>	$I_{OUT}=40mA$ $1.8V \leq V_{OUT(T)}$	$\times 0.98$	$V_{OUT(T)}$ <sup>(3)</sup>	$\times 1.02$	V	②
Maximum Output Current	$I_{OUTMAX}$	$V_{OUT} \geq E-1$ <sup>(4)</sup>	$E-2$ <sup>(4)</sup>	-	-	mA	②
Load Regulation	$\Delta V_{OUT}$	$1.8V \leq V_{OUT(T)}$ $1mA \leq I_{OUT} \leq 150mA$	-	40	100	mV	②
Dropout Voltage 1	$V_{dif1}$ <sup>(5)</sup>	$I_{OUT}=100mA$	-	$E-3$ <sup>(4)</sup>		mV	②
Dropout Voltage 2	$V_{dif2}$ <sup>(5)</sup>	$I_{OUT}=200mA$	-	$E-4$ <sup>(4)</sup>		mV	
Supply Current	$I_{DD}$		-	$E-5$ <sup>(4)</sup>		$\mu A$	①
Line Regulation	$\frac{\Delta V_{OUT}}{(\Delta V_{IN} \cdot V_{OUT})}$	$1.8V \leq V_{OUT(T)}$ , $V_{OUT(T)}+1.0V \leq V_{IN} \leq 8.0V$ , $I_{OUT}=40mA$	-	0.2	0.3	%/V	②
Input Voltage	$V_{IN}$		-	-	8.0	V	②
Output Voltage Temperature Characteristics	$\frac{\Delta V_{OUT}}{(\Delta T_{opr} \cdot V_{OUT})}$	$I_{OUT}=40mA$ $-40^{\circ}C \leq T_{opr} \leq 85^{\circ}C$	-	$\pm 100$	-	ppm/°C	②

\*1: Unless otherwise stated,  $V_{IN}=V_{OUT(T)}+1.0V$

\*2:  $V_{OUT(E)}$ : Effective output voltage

\*3:  $V_{OUT(T)}$ : Nominal output voltage.

\*4: Please refer to the table E-1, E-2, E-3, E-4, E-5.

\*5:  $V_{dif} = \{V_{IN1} - V_{OUT1}\}$

$V_{IN1}$ : The input voltage when  $V_{OUT1}$  appears as input voltage is gradually decreased.

$V_{OUT1}$ : A voltage equal to 98% of the output voltage when " $V_{OUT(T)} + 1.0V$ " is input.

## ■ ELECTRICAL CHARACTERISTICS (Continued)

XC6203 Series Type P

Ta=25°C

PARAMETER	SYMBOL	CONDITIONS	MIN.	TYP.	MAX.	UNITS	CIRCUIT
Output Voltage	$V_{OUT(E)}^{(*)2}$	$I_{OUT}=40mA$   $1.8V \leq V_{OUT(T)}$	$\times 0.98$	$V_{OUT(T)}^{(*)3}$	$\times 1.02$	V	②
Maximum Output Current	$I_{OUTMAX}$	$V_{OUT} \geq E-1^{(*)4}$	$E-2^{(*)4}$	-	-	mA	②
Load Regulation	$\Delta V_{OUT}$	$1.8V \leq V_{OUT(T)}$ $1mA \leq I_{OUT} \leq 200mA$	-	40	100	mV	②
Dropout Voltage 1	$V_{dif1}^{(*)5}$	$I_{OUT}=100mA$	-	$E-3^{(*)4}$		mV	②
Dropout Voltage 2	$V_{dif2}^{(*)5}$	$I_{OUT}=200mA$	-	$E-4^{(*)4}$		mV	
Supply Current	$I_{DD}$		-	$E-5^{(*)4}$		$\mu A$	①
Line Regulation	$\frac{\Delta V_{OUT}}{(\Delta V_{IN} \cdot V_{OUT})}$	$1.8V \leq V_{OUT(T)}$ $V_{OUT(T)} + 1.0V \leq V_{IN} \leq 8.0V$ $I_{OUT}=40mA$	-	0.2	0.3	%/V	②
Input Voltage	$V_{IN}$		-	-	8.0	V	②
Output Voltage Temperature Characteristics	$\frac{\Delta V_{OUT}}{(\Delta T_{opr} \cdot V_{OUT})}$	$I_{OUT}=40mA$ $-40^{\circ}C \leq T_{opr} \leq 85^{\circ}C$	-	$\pm 100$	-	ppm/°C	②
Short-Circuit Current	$I_{SHORT}$	$V_{OUT}=V_{SS}$	-	60	-	mA	②

\*1: Unless otherwise stated,  $V_{IN}=V_{OUT(T)}+1.0V$

\*2:  $V_{OUT(E)}$ : Effective output voltage

\*3:  $V_{OUT(T)}$ : Nominal output voltage.

\*4: Please refer to the table E-1, E-2, E-3, E-4, E-5.

\*5:  $V_{dif} = \{V_{IN1} - V_{OUT1}\}$

$V_{IN1}$ : The input voltage when  $V_{OUT1}$  appears as input voltage is gradually decreased.

$V_{OUT1}$ : A voltage equal to 98% of the output voltage when " $V_{OUT(T)} + 1.0V$ " is input.

## ■ ELECTRICAL CHARACTERISTICS (Continued)

NOMINAL OUTPUT VOLTAGE	E-1	E-2	E-3		E-4		E-5	
	MAXIMUM OUTPUT VOLTAGE		DROPOUT VOLTAGE1		DROPOUT VOLTAGE2		SUPPLY CURRENT	
	V <sub>OUT2</sub> (V)	I <sub>OUTMAX</sub> (mA)	V <sub>diff1</sub> (mV)		V <sub>diff2</sub> (mV)		I <sub>SS</sub> (μA)	
V <sub>OUT(T)</sub>	-	MIN.	TYP.	MAX.	TYP.	MAX.	TYP.	MAX.
1.8	V <sub>OUT(E)</sub> × 0.9	400	200	300	400	600	8.0	16.0
1.9								
2.0								
2.1								
2.2								
2.3								
2.4	V <sub>OUT(E)</sub> × 0.93		170	250	320	500		
2.5								
2.6								
2.7								
2.8								
2.85								
2.9	V <sub>OUT(E)</sub> × 0.96	150	220	300	420	10.0	20.0	
3.0								
3.1								
3.2								
3.3								
3.4								
3.5								
3.6								
3.7								
3.8								
3.9								
4.0								
4.1								
4.2								
4.3								
4.4								
4.5								
4.6								
4.7								
4.8								
4.9								
5.0								
5.1								
5.2								
5.3								
5.4								
5.5								

\*) The symbol is as same as that in the chart of electrical characteristics.

■ ELECTRICAL CHARACTERISTICS (Continued)

NOMINAL OUTPUT VOLTAGE	E-1	E-2	E-3		E-4		E-5	
	MAXIMUM OUTPUT VOLTAGE		DROPOUT VOLTAGE1		DROPOUT VOLTAGE2		SUPPLY CURRENT	
	$V_{OUT2}$ (V)	$I_{OUTMAX}$ (mA)	$V_{dif1}$ (mV)		$V_{dif2}$ (mV)		$I_{SS}$ ( $\mu$ A)	
$V_{OUT(T)}$	-	MIN.	TYP.	MAX.	TYP.	MAX.	TYP.	MAX.
5.6	$V_{OUT(E)} \times 0.96$	400	100	180	200	320	10.0	20.0
5.7								
5.8								
5.9								
6.0								

\*) The symbol is as same as that in the chart of electrical characteristics.

## TYPICAL APPLICATION CIRCUIT

1) CIRCUIT①

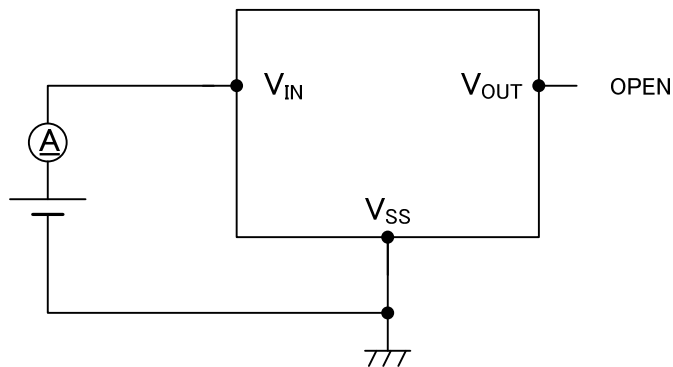

2) CIRCUIT②

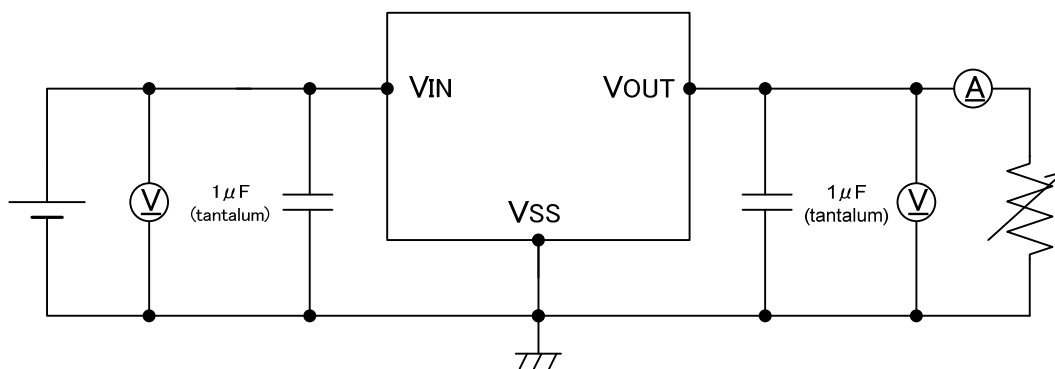

## NOTES ON USE

1. For temporary, transitional voltage drop or voltage rising phenomenon, the IC is liable to malfunction should the ratings be exceeded.
2. Where wiring impedance is high, operations may become unstable due to noise and/or phase lag depending on output current. Please keep the resistance low for the  $V_{BIAS}$ ,  $V_{IN}$  and  $V_{SS}$  wiring in particular.
3. Please wire the  $C_{IN}$  and  $C_L$  as close to the IC as possible.
4. Capacitances of these capacitors ( $C_{IN}$ ,  $C_L$ ) are decreased by the influences of bias voltage and ambient temperature. Care shall be taken for capacitor selection to ensure stability of phase compensation from the point of ESR influence.
5. When it is used in a quite small input / output dropout voltage, output may go into unstable operation. Please test it thoroughly before using it in production.
6. Torex places an importance on improving our products and their reliability. We request that users incorporate fail-safe designs and post-aging protection treatment when using Torex products in their systems.



## ■ TYPICAL PERFORMANCE CHARACTERISTICS

### ● XC6203E182PR

(1) Output Voltage vs. Output Current

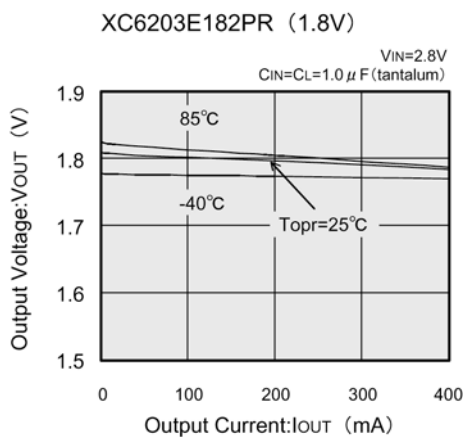

(2) Output Voltage vs. Input Voltage

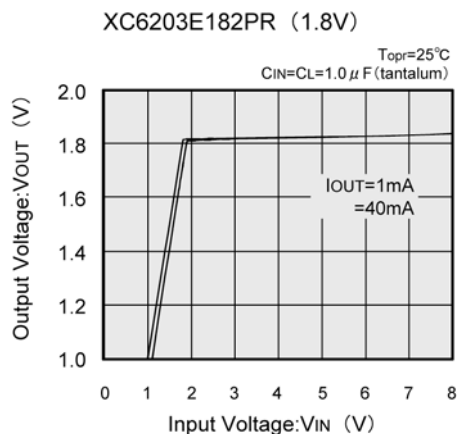

(3) Dropout Voltage vs. Output Current

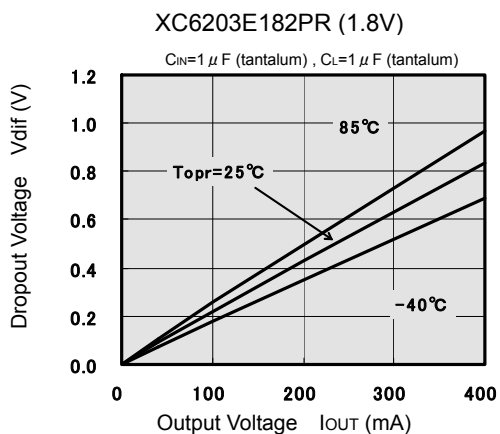

(4) Supply Current vs. Input Voltage

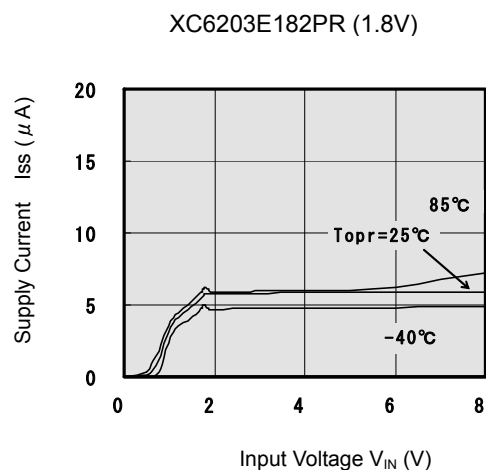

(5) Output Voltage vs. Ambient Temperature

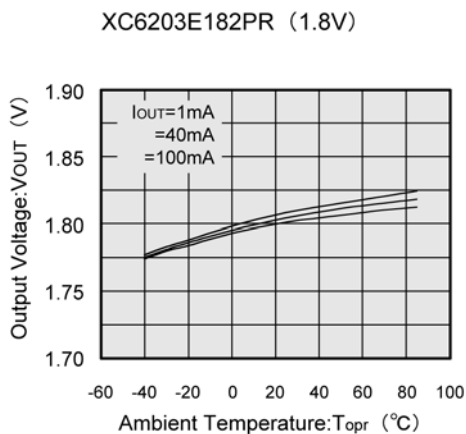

(6) Supply Current vs. Ambient Temperature

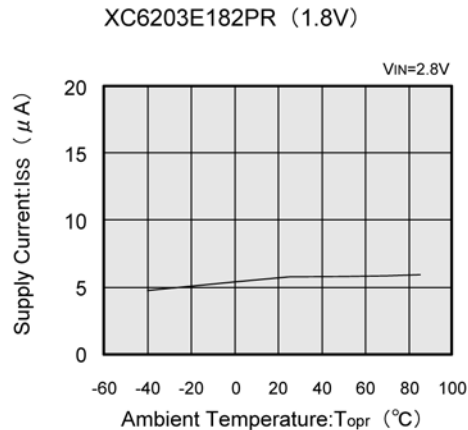

## TYPICAL PERFORMANCE CHARACTERISTICS (Continued)

### ●XC6203E182PR (Continued)

#### (7) Input Transient Response

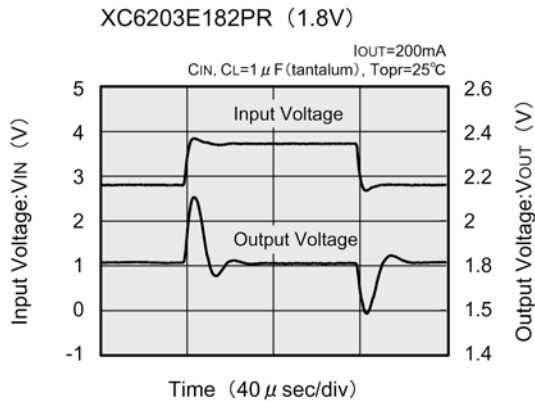

#### (8) Load Transient Response

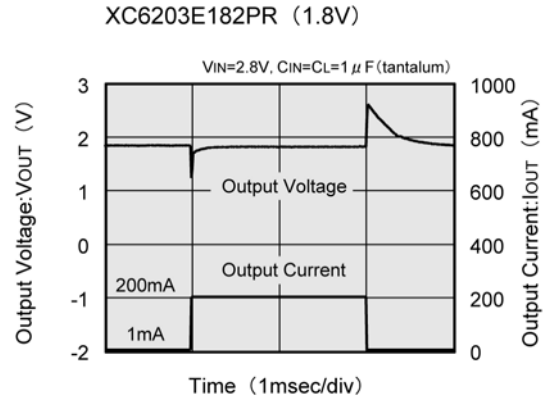
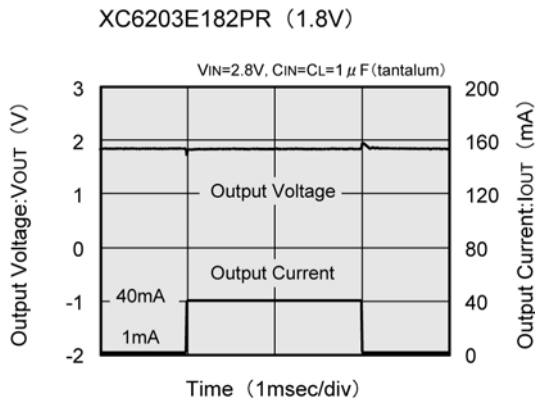

#### (9) Ripple Rejection Rate

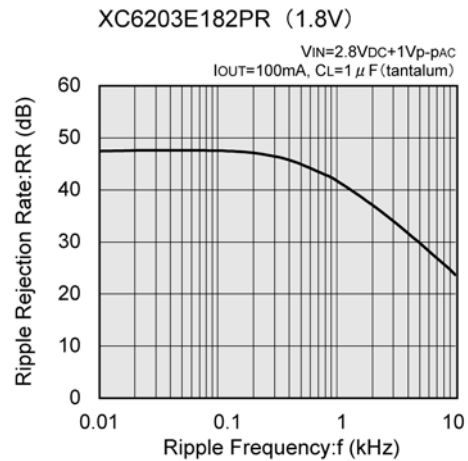
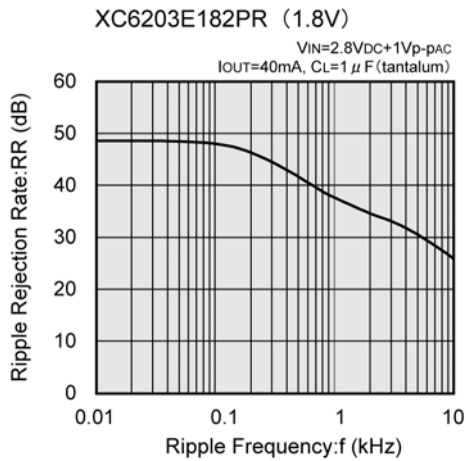

## ■ TYPICAL PERFORMANCE CHARACTERISTICS (Continued)

● XC6203E252PR

(1) Output Voltage vs. Output Current

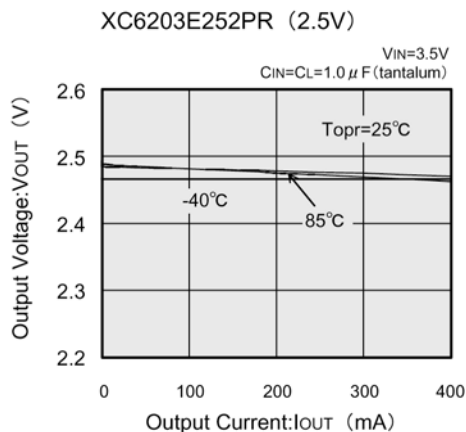

(2) Output Voltage vs. Input Voltage

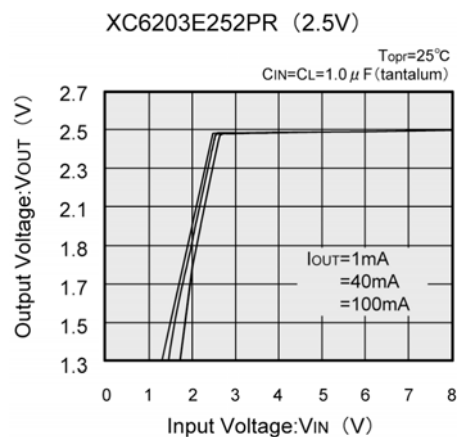

(3) Dropout Voltage vs. Output Current

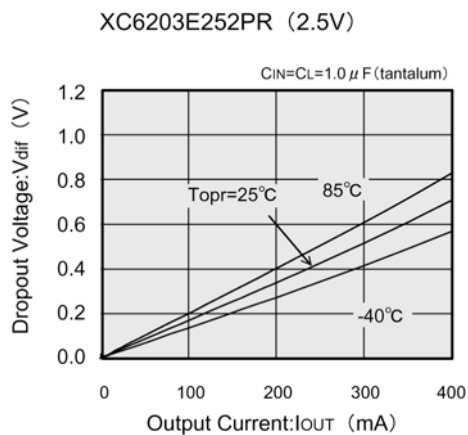

(4) Supply Current vs. Input Voltage

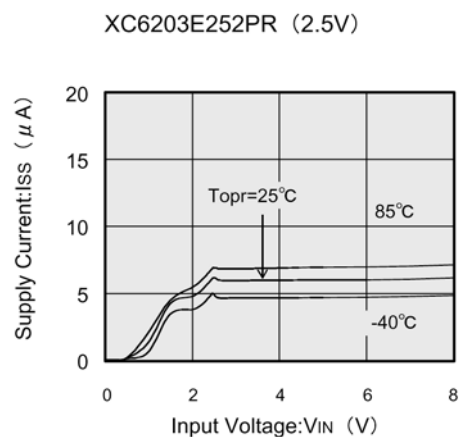

(5) Output Voltage vs. Ambient Temperature

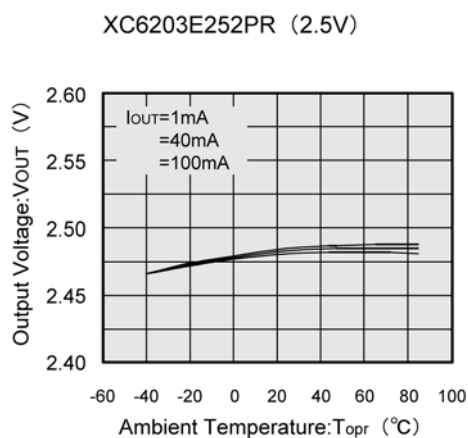

(6) Supply Current vs. Ambient Temperature

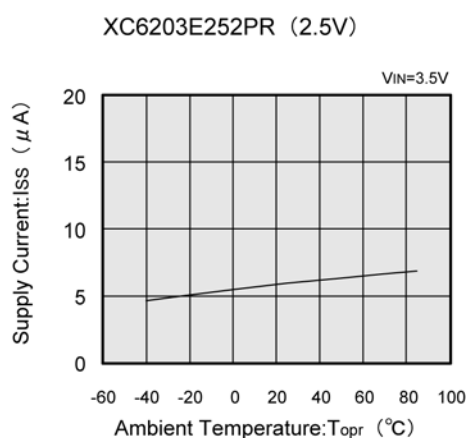

## TYPICAL PERFORMANCE CHARACTERISTICS (Continued)

### ●XC6203E252PR (Continued)

#### (7) Input Transient Response

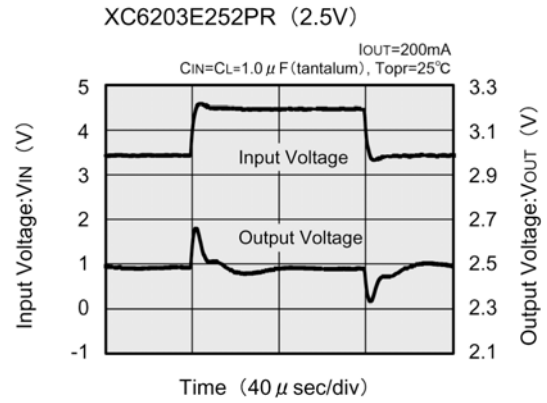
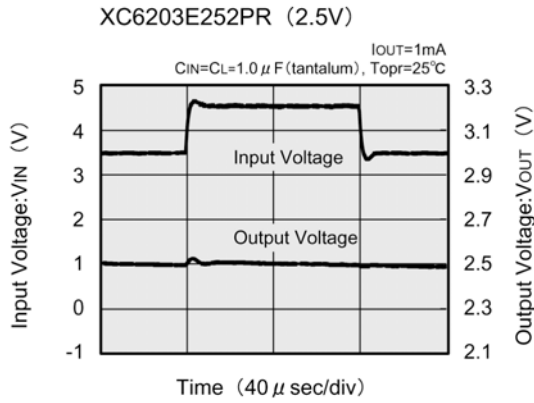

#### (8) Load Transient Response

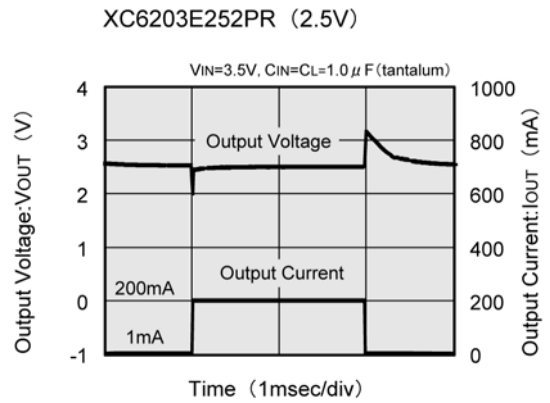
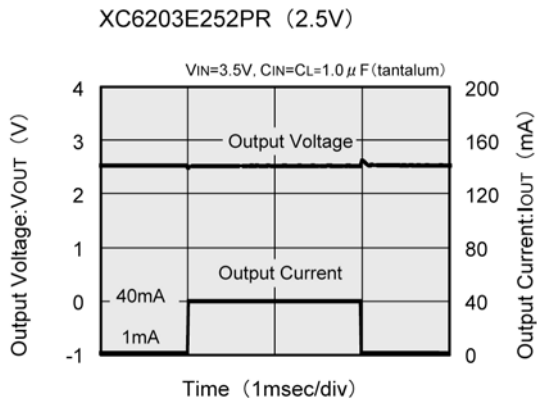

#### (9) Ripple Rejection Rate

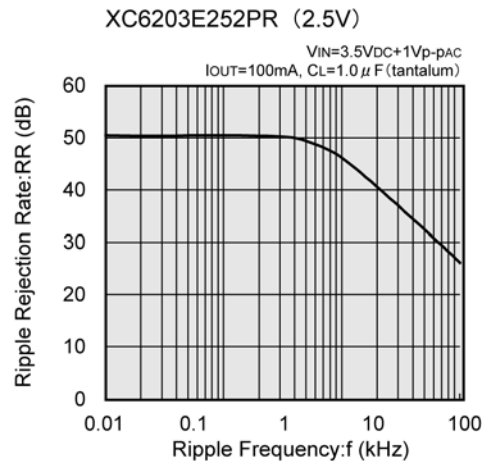
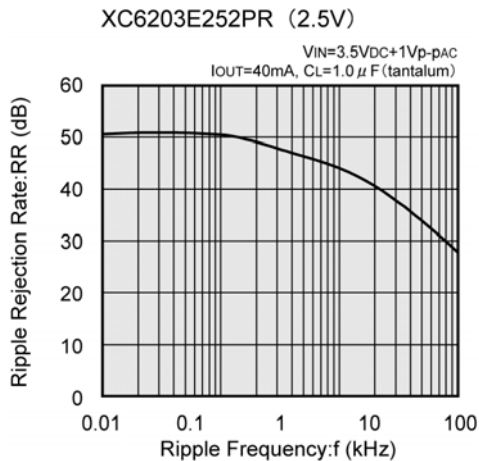

## ■ TYPICAL PERFORMANCE CHARACTERISTICS (Continued)

● XC6203E332PR

(1) Output Voltage vs. Output Current

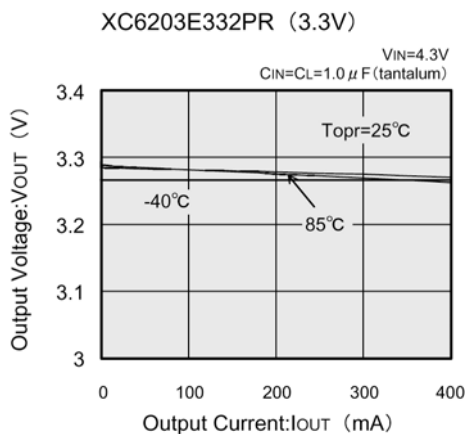

(2) Output Voltage vs. Input Voltage

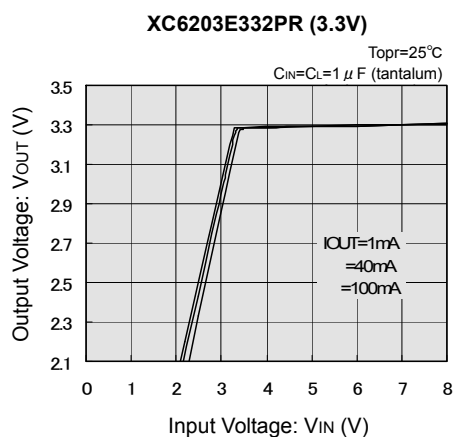

(3) Dropout Voltage vs. Output Current

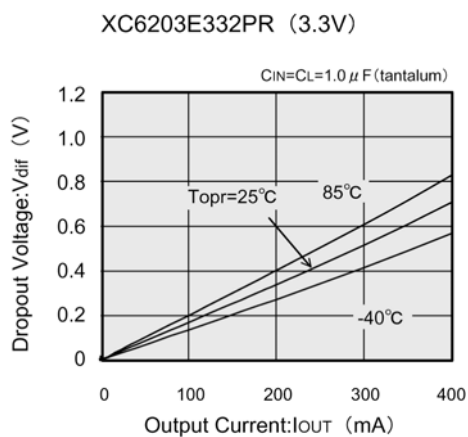

(4) Supply Current vs. Input Voltage

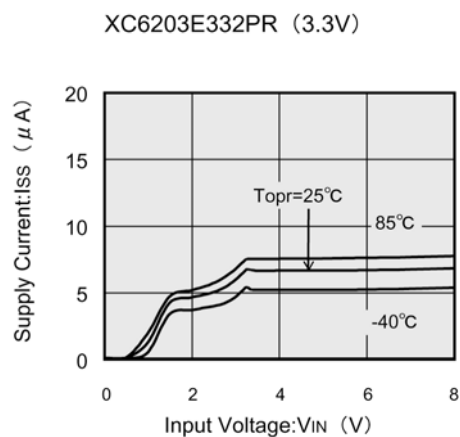

(5) Output Voltage vs. Ambient Temperature

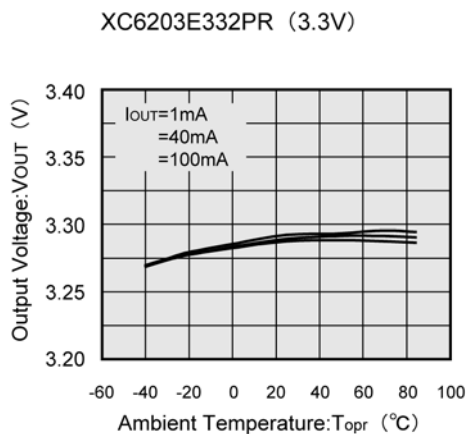

(6) Supply Current vs. Ambient Temperature

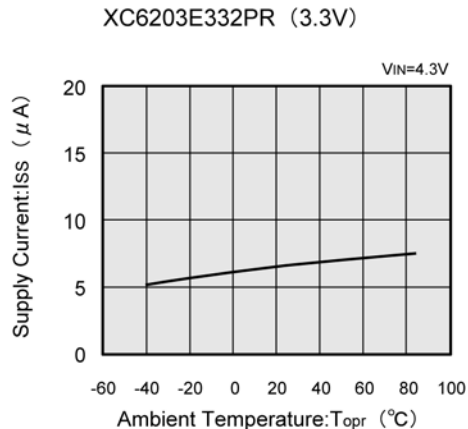

## TYPICAL PERFORMANCE CHARACTERISTICS (Continued)

### ●XC6203E332PR (Continued)

#### (7) Input Transient Response

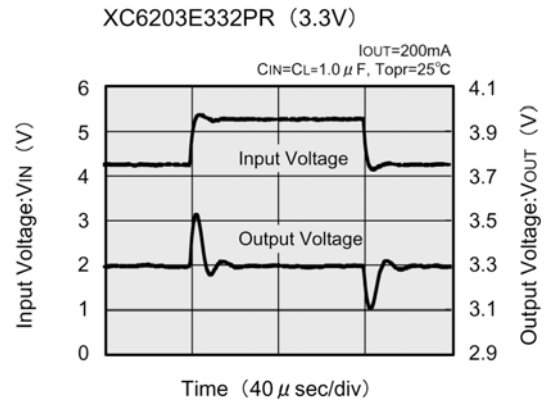
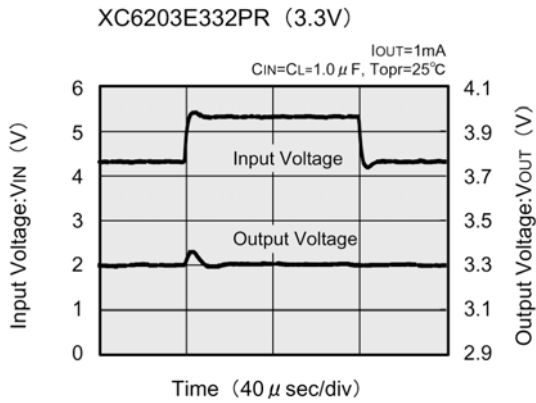

#### (8) Load Transient Response

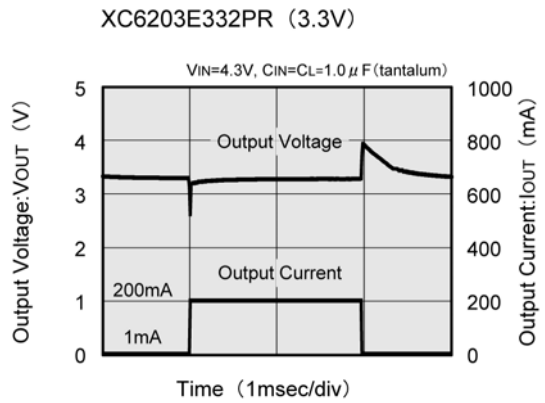
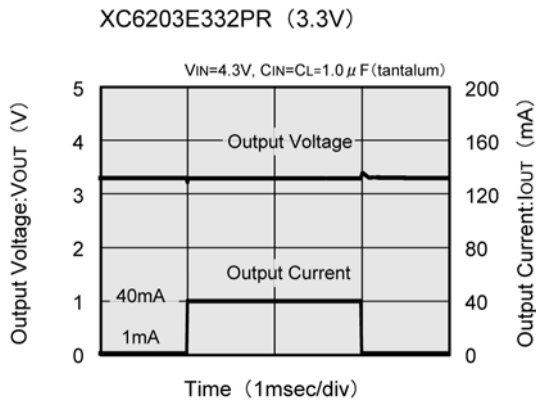

#### (9) Ripple Rejection Rate

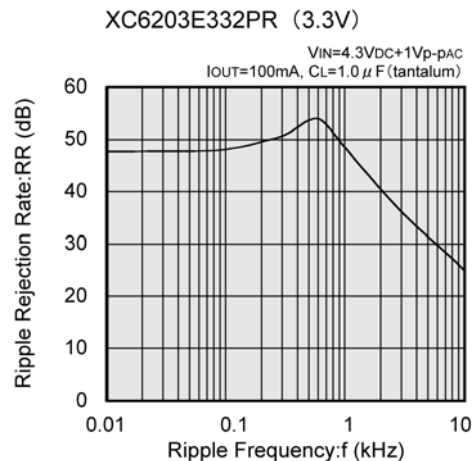
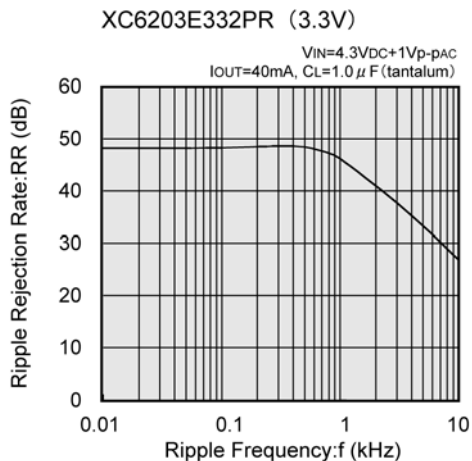

## ■ TYPICAL PERFORMANCE CHARACTERISTICS (Continued)

● XC6203E502PR

(1) Output Voltage vs. Output Current

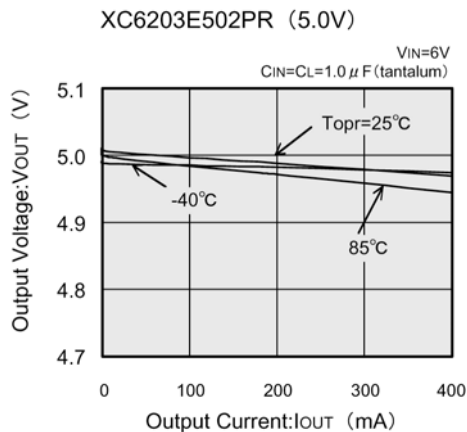

(2) Output Voltage vs. Input Voltage

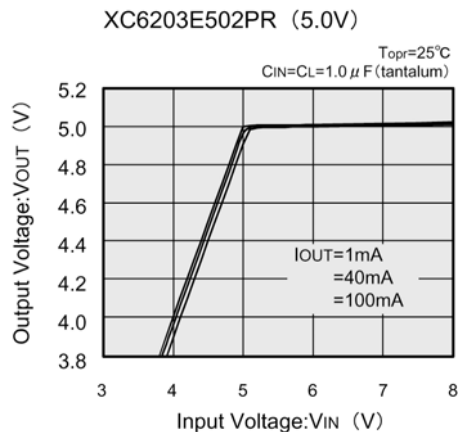

(3) Dropout Voltage vs. Output Current

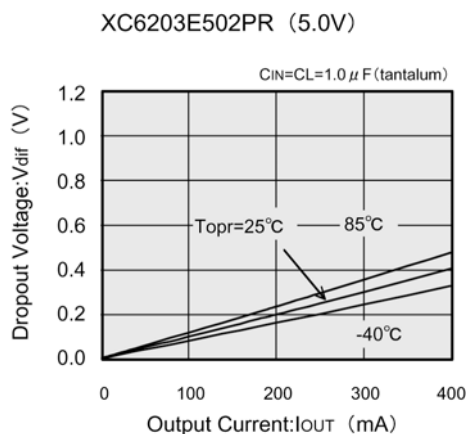

(4) Supply Current vs. Input Voltage

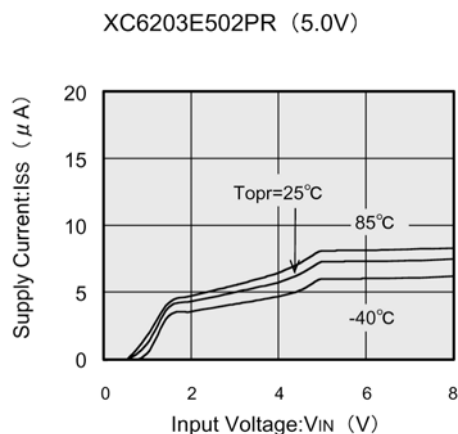

(5) Output Voltage vs. Ambient Temperature

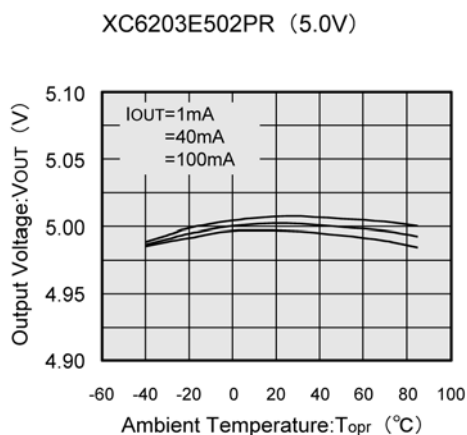

(6) Supply Current vs. Ambient Temperature

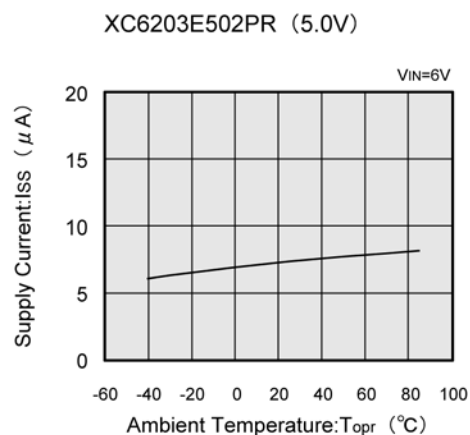

## TYPICAL PERFORMANCE CHARACTERISTICS (Continued)

### ●XC6203E502PR (Continued)

#### (7) Input Transient Response

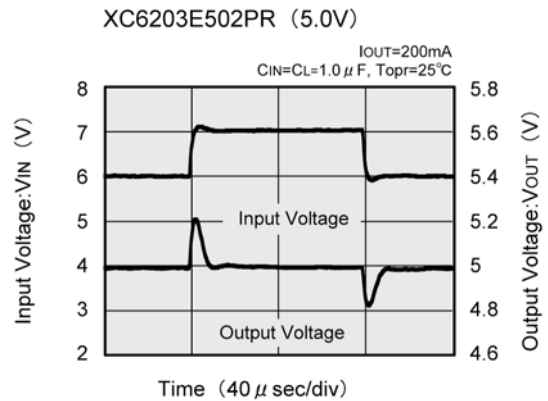
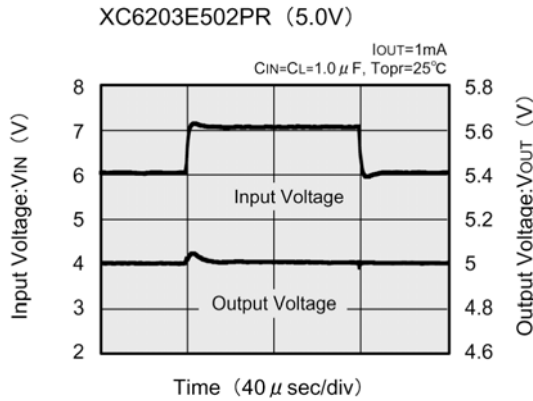

#### (8) Load Transient Response

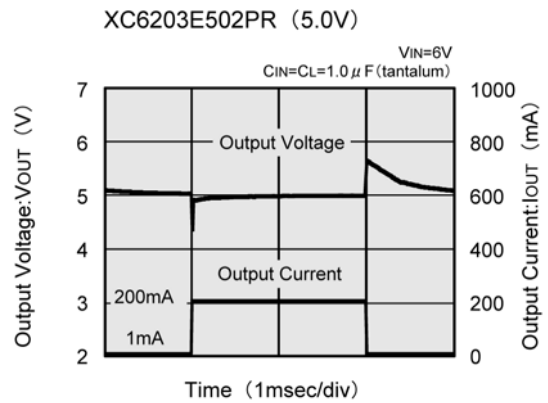
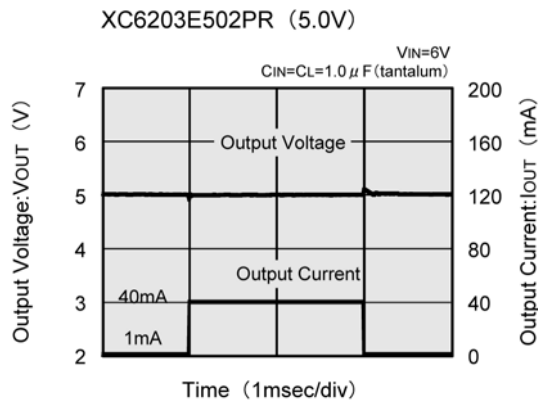

#### (9) Ripple Rejection Rate

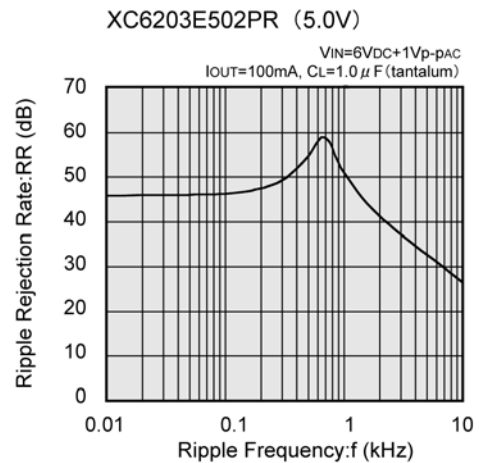
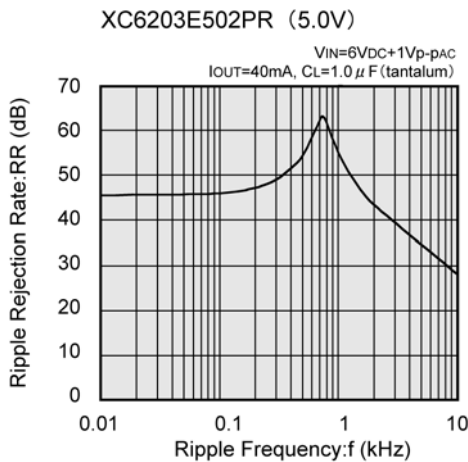



■ TYPICAL PERFORMANCE CHARACTERISTICS (Continued)

(10) Output Voltage vs. Output Current

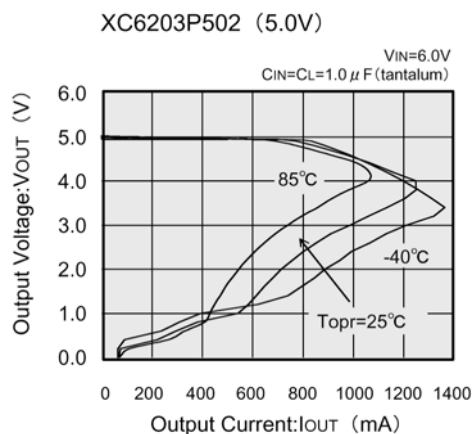
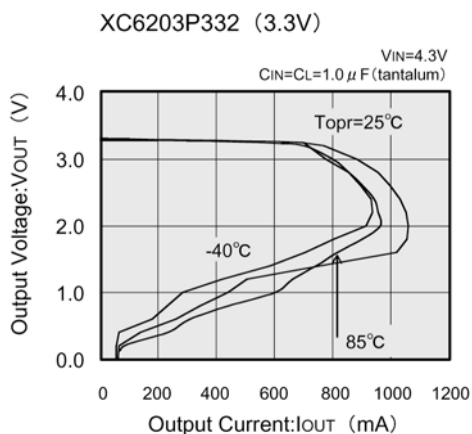
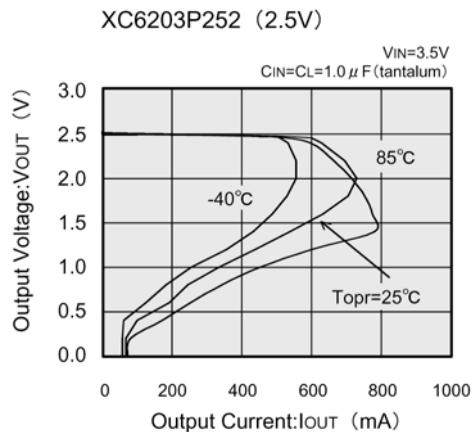
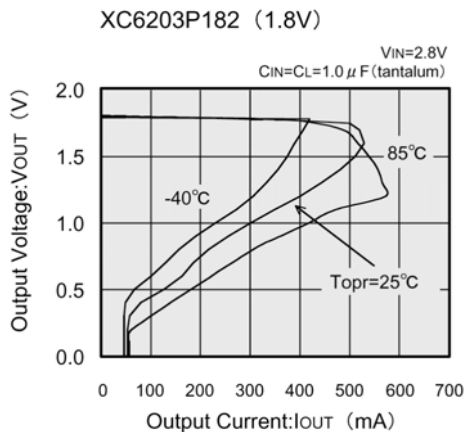

## PACKAGING INFORMATION

### ● SOT-89

(unit : mm)

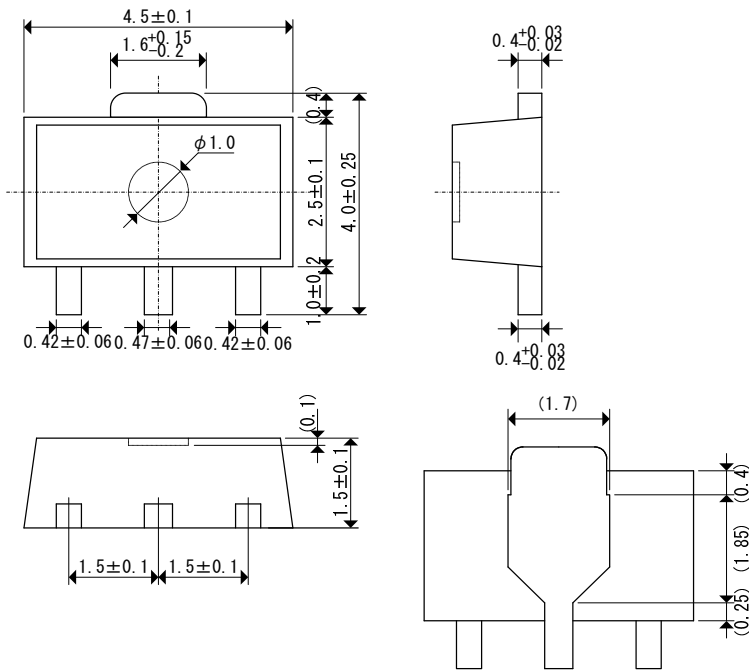

### ● SOT-23

(unit : mm)

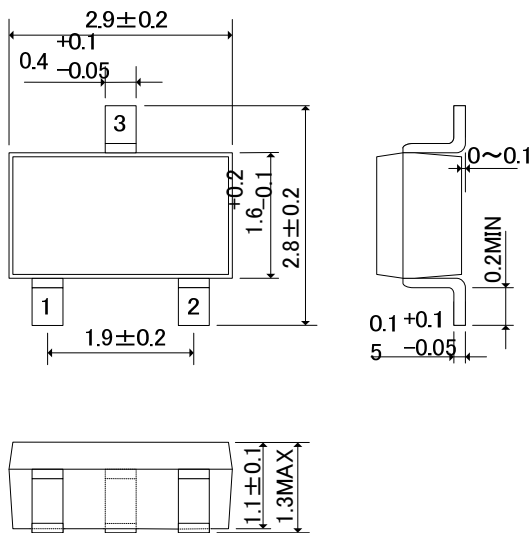

■ PACKAGING INFORMATION (Continued)

● SOT-223

(unit : mm)

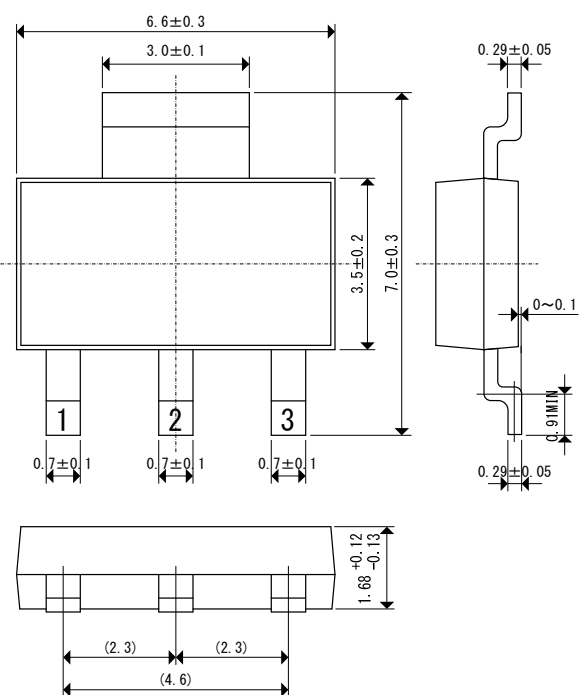

## PACKAGING INFORMATION (Continued)

### ●SOT-23 Power Dissipation

Power dissipation data for the SOT-23 is shown in this page.  
The value of power dissipation varies with the mount board conditions.  
Please use this data as the reference data taken in the following.

#### 1. Measurement Condition

- Condition : Mount on a board
- Ambient : Natural convection
- Soldering : Lead (Pb) free
- Board : Dimensions 40×40mm (1600mm<sup>2</sup> in one side)
- Copper (Cu) traces occupy 50% of the board area
- In top and back faces
- Package heat-sink is tied to the copper traces
- (Board of SOT-26 is used)
- Material : Glass Epoxy (FR-4)
- Thickness : 1.6mm
- Through-hole : 4 x 0.8 Diameter

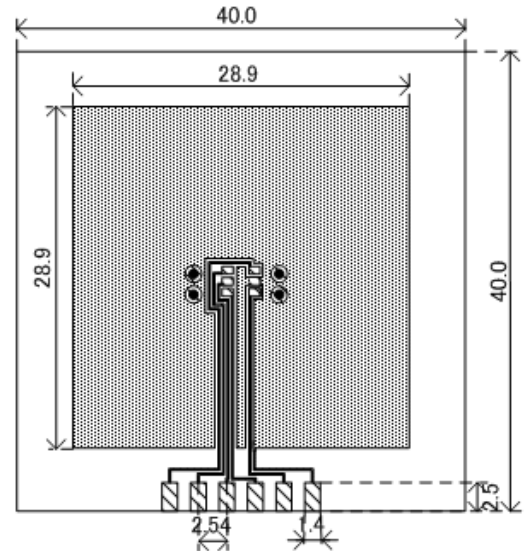

Evaluation Board (Unit: mm)

#### 2. Power Dissipation vs. Ambient Temperature

Board Mount (  $T_{jmax}=125^{\circ}C$  )

Ambient Temperature ( $^{\circ}C$ )	Power Dissipation Pd (mW)	Thermal Resistance ( $^{\circ}C/W$ )
25	500	200.00
85	200	

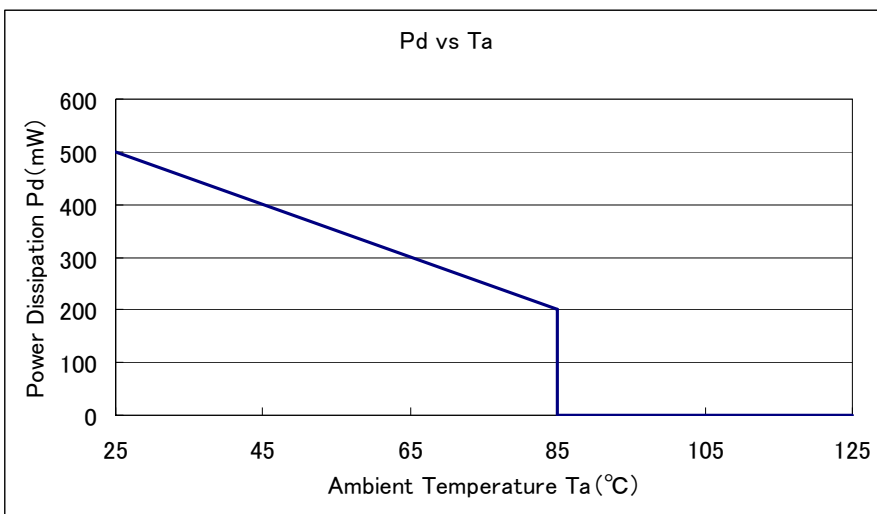

## ■ PACKAGING INFORMATION (Continued)

### ● SOT-89 Power Dissipation

Power dissipation data for the SOT-89 is shown in this page.  
The value of power dissipation varies with the mount board conditions.  
Please use this data as the reference data taken in the following.

#### 1. Measurement Condition

- Condition : Mount on a board
- Ambient : Natural convection
- Soldering : Lead (Pb) free
- Board : Dimensions 40×40mm (1600mm<sup>2</sup> in one side)
- Copper (Cu) traces occupy 50% of the board area
- In top and back faces
- Package heat-sink is tied to the copper traces
- Material : Glass Epoxy (FR-4)
- Thickness : 1.6mm
- Through-hole : 5 x 0.8 Diameter

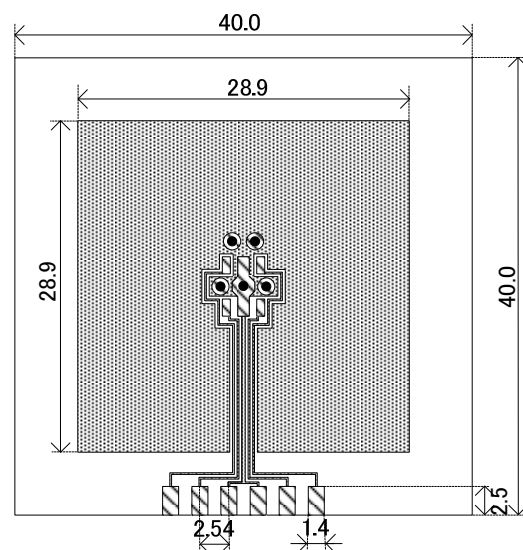

Evaluation Board (Unit: mm)

#### 2. Power Dissipation vs. Ambient Temperature

Board Mount (  $T_{jmax}=125^{\circ}\text{C}$  )

Ambient Temperature (°C)	Power Dissipation Pd (mW)	Thermal Resistance (°C/W)
25	1000	100.00
85	400	

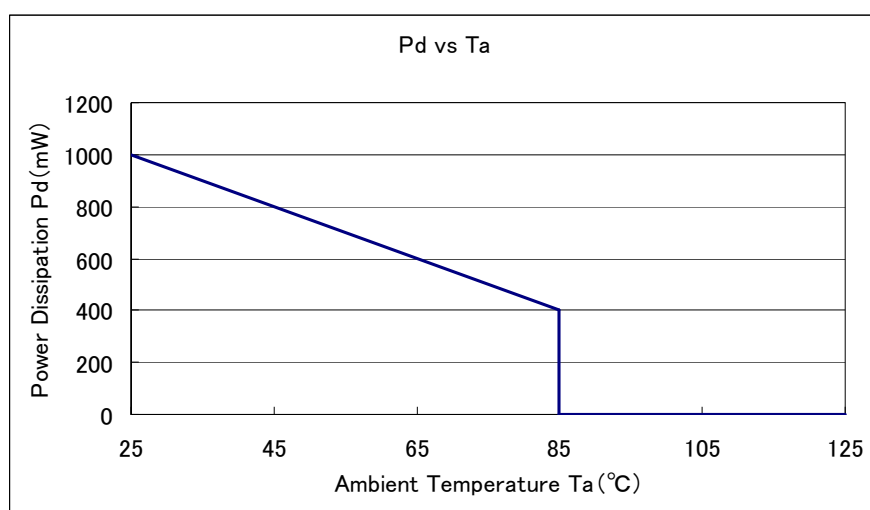

## ■ PACKAGING INFORMATION (Continued)

### ● SOT-223 Power Dissipation

Power dissipation data for the SOT-223 is shown in this page.  
The value of power dissipation varies with the mount board conditions.  
Please use this data as the reference data taken in the following condition.

#### 1. Measurement Condition

- Condition: Mount on a board
- Ambient: Natural convection
- Soldering: Lead (Pb) free
- Board: Dimensions 40 x 40 mm (1600 mm<sup>2</sup> in one side)  
Copper (Cu) traces occupy 50% of the board area  
In top and back faces  
Package heat-sink is tied to the copper traces
- Material: Glass Epoxy (FR-4)
- Thickness: 1.6 mm
- Through-hole: 4 x 0.8 Diameter

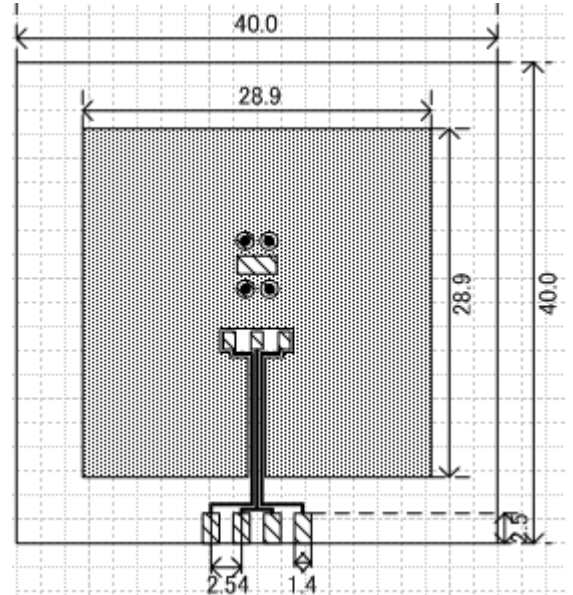

Evaluation Board (Unit: mm)

#### 2. Power Dissipation vs. Ambient Temperature

Board Mount ( $T_j \text{ max} = 125^\circ\text{C}$ )

Ambient Temperature (°C)	Power Dissipation Pd (mW)	Thermal Resistance (°C/W)
25	1500	66.67
85	600	

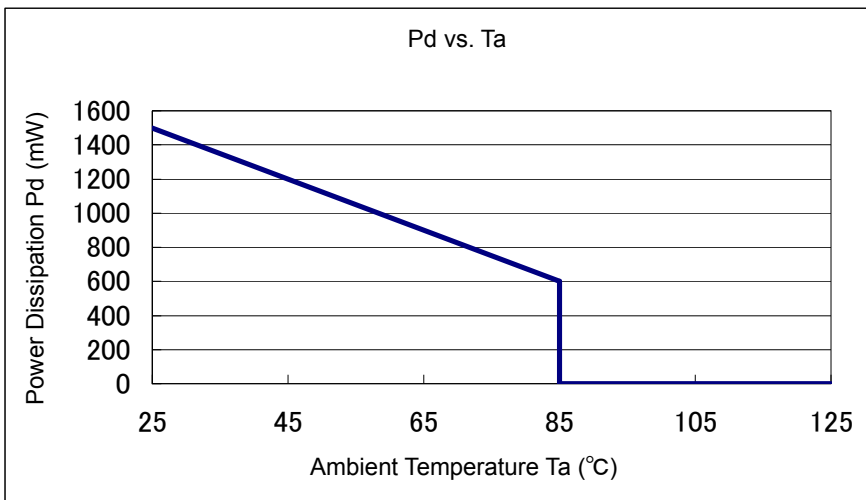

## MARKING RULE

### ● SOT-23, SOT-89, SOT-223

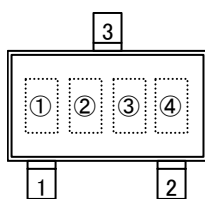

SOT-23  
(TOP VIEW)

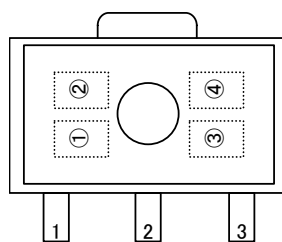

SOT-89  
(TOP VIEW)

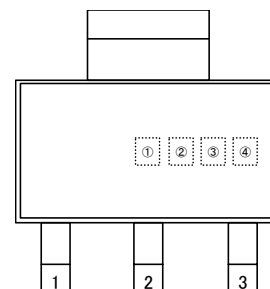

SOT-223  
(TOP VIEW)

① represents product series

MARK	PRODUCT SERIES
3	XC6203xxxx

② represents type of regulator

MARK			PRODUCT SERIES
VOLTAGE=0.1~3.0V	VOLTAGE=3.1~6.0V	VOLTAGE=2.85V	
5	6	7	XC6203Pxxxx
2	3	4	XC6203Exxxxx

③ represents output voltage

MARK	OUTPUT VOLTAGE (V)			MARK	OUTPUT VOLTAGE (V)		
0	—	3.1	—	F	—	4.6	—
1	—	3.2	—	H	—	4.7	—
2	—	3.3	—	K	1.8	4.8	—
3	—	3.4	—	L	1.9	4.9	—
4	—	3.5	—	M	2.0	5.0	—
5	—	3.6	—	N	2.1	5.1	—
6	—	3.7	—	P	2.2	5.2	—
7	—	3.8	—	R	2.3	5.3	—
8	—	3.9	—	S	2.4	5.4	—
9	—	4.0	—	T	2.5	5.5	—
A	—	4.1	—	U	2.6	5.6	—
B	—	4.2	—	V	2.7	5.7	—
C	—	4.3	—	X	2.8	5.8	2.85
D	—	4.4	—	Y	2.9	5.9	—
E	—	4.5	—	Z	3.0	6.0	—

④ represents production lot number

0~9, A to Z or inverted characters of 0 to 9 and A to Z repeated (G, I, J, O, Q, W excluded)

1. The product and product specifications contained herein are subject to change without notice to improve performance characteristics. Consult us, or our representatives before use, to confirm that the information in this datasheet is up to date.
2. The information in this datasheet is intended to illustrate the operation and characteristics of our products. We neither make warranties or representations with respect to the accuracy or completeness of the information contained in this datasheet nor grant any license to any intellectual property rights of ours or any third party concerning with the information in this datasheet.
3. Applicable export control laws and regulations should be complied and the procedures required by such laws and regulations should also be followed, when the product or any information contained in this datasheet is exported.
4. The product is neither intended nor warranted for use in equipment of systems which require extremely high levels of quality and/or reliability and/or a malfunction or failure which may cause loss of human life, bodily injury, serious property damage including but not limited to devices or equipment used in 1) nuclear facilities, 2) aerospace industry, 3) medical facilities, 4) automobile industry and other transportation industry and 5) safety devices and safety equipment to control combustions and explosions. Do not use the product for the above use unless agreed by us in writing in advance.
5. Although we make continuous efforts to improve the quality and reliability of our products; nevertheless Semiconductors are likely to fail with a certain probability. So in order to prevent personal injury and/or property damage resulting from such failure, customers are required to incorporate adequate safety measures in their designs, such as system fail safes, redundancy and fire prevention features.
6. Our products are not designed to be Radiation-resistant.
7. Please use the product listed in this datasheet within the specified ranges.
8. We assume no responsibility for damage or loss due to abnormal use.
9. All rights reserved. No part of this datasheet may be copied or reproduced unless agreed by Torex Semiconductor Ltd in writing in advance.

TOREX SEMICONDUCTOR LTD.