



**Robert Bosch Power Tools GmbH**  
70538 Stuttgart  
GERMANY

[www.bosch-pt.com](http://www.bosch-pt.com)

**1 609 92A 3L4** (2014.11) AS / 7 XXX



1 609 92A 3L4

## TBM 3500 Professional



cn 正本使用说明书



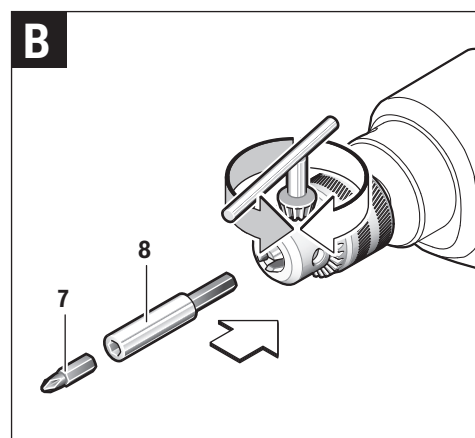
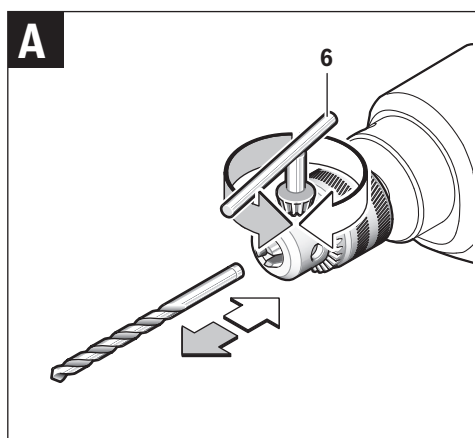
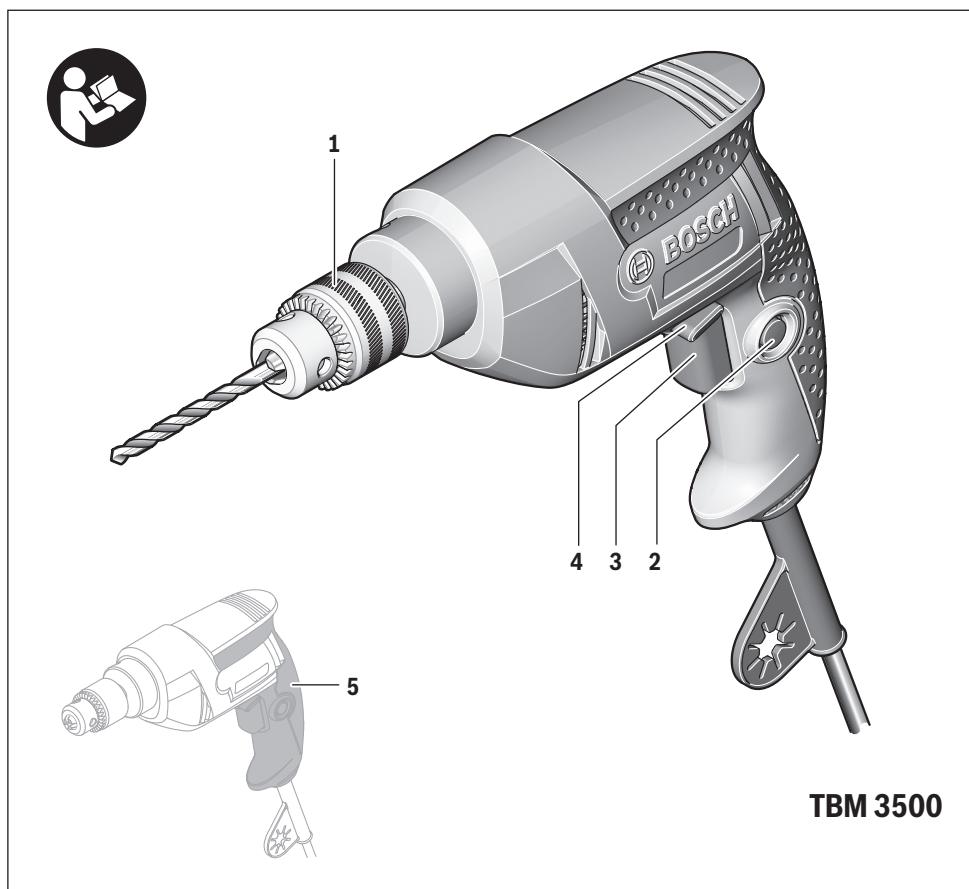

## 中文

### 安全规章

#### 电动工具通用安全警告

**警告！** 阅读所有警告和所有说明！不遵照以下警告和说明会导致电击、着火和/或严重伤害。

保存所有警告和说明书以备查阅。

在所有下列的警告中术语“电动工具”指市电驱动（有线）电动工具或电池驱动（无线）电动工具。

#### 工作场地的安全

- ▶ **保持工作场地清洁和明亮。** 混乱和黑暗的场地会引发事故。
- ▶ **不要在易爆环境，如有易燃液体、气体或粉尘的环境下操作电动工具。** 电动工具产生的火花会点燃粉尘或气体。
- ▶ **让儿童和旁观者离开后操作电动工具。** 注意力不集中会使操作者失去对工具的控制。

#### 电气安全

- ▶ **电动工具插头必须与插座相配。** 绝不能以任何方式改装插头。需接地的电动工具不能使用任何转换插头。未经改装的插头和相配的插座将减少电击危险。
- ▶ **避免人体接触接地表面，如管道、散热片和冰箱。** 如果你身体接地会增加电击危险。
- ▶ **不得将电动工具暴露在雨中或潮湿环境中。** 水进入电动工具将增加电击危险。
- ▶ **不得滥用电线。** 绝不能用电线搬运、拉动电动工具或拔出其插头。使电线远离热源、油、锐边或运动部件。受损或缠绕的软线会增加电击危险。
- ▶ **当在户外使用电动工具时，使用适合户外使用的外接软线。** 适合户外使用的软线将减少电击危险。
- ▶ **如果在潮湿环境下操作电动工具是不可避免的，应使用剩余电流动作保护器（RCD）。** 使用 RCD 可减少电击危险。

#### 人身安全

- ▶ **保持警觉，当操作电动工具时关注所从事的操作并保持清醒。** 当你感到疲倦，或在有药物、酒精或治疗反应时，不要操作电动工具。在操作电动工具时瞬间的疏忽会导致严重人身伤害。
- ▶ **使用个人防护装置。始终佩戴护目镜。** 安全装置，诸如适当条件下使用防尘面具、防滑安全鞋、安全帽、听力防护等装置能减少人身伤害。
- ▶ **防止意外起动。** 确保开关在连接电源和/或电池盒、拿起或搬运工具时处于关断位置。手指放在已接通电源的开关上或开关处于接通时插入插头可能会导致危险。

- ▶ **在电动工具接通之前，拿掉所有调节钥匙或扳手。** 遗留在电动工具旋转零件上的扳手或钥匙会导致人身伤害。
- ▶ **手不要伸展得太长。时刻注意立足点和身体平衡。** 这样在意外情况下能很好地控制电动工具。
- ▶ **着装适当。不要穿宽松衣服或佩戴饰品。让衣服、手套和头发远离运动部件。** 宽松衣服、佩饰或长发可能会卷入运动部件中。
- ▶ **如果提供了与排屑、集尘设备连接用的装置，要确保他们连接完好且使用得当。** 使用这些装置可减少尘屑引起的危险。

#### 电动工具使用和注意事项

- ▶ **不要滥用电动工具，根据用途使用适当的电动工具。** 选用适当设计的电动工具会使你工作更有效、更安全。
- ▶ **如果开关不能接通或关断工具电源，则不能使用该电动工具。** 不能用开关来控制的电动工具是危险的且必须进行修理。
- ▶ **在进行任何调节、更换附件或贮存电动工具之前，必须从电源上拔掉插头和/或使电池盒与工具脱开。** 这种防护性措施将减少工具意外起动的危险。
- ▶ **将闲置不用的电动工具贮存在儿童所及范围之外，并且不要让不熟悉电动工具或对这些说明不了解的人操作电动工具。** 电动工具在未经培训的用户手中是危险的。
- ▶ **保养电动工具。检查运动件是否调整到位或卡住，检查零件破损情况和影响电动工具运行的其他状况。如有损坏，电动工具应在使用前修理好。** 许多事故由维护不良的电动工具引发。
- ▶ **保持切削刀具锋利和清洁。** 保养良好的有锋利切削刃的刀具不易卡住而且容易控制。
- ▶ **按照使用说明书，考虑作业条件和进行的作业来使用电动工具、附件和工具的刀头等。** 将电动工具用于那些与其用途不符的操作可能会导致危险。

#### 维修

- ▶ **将你的电动工具送交专业维修人员，使用同样的备件进行修理。** 这样将确保所维修的电动工具的安全性。

#### 针对电钻的安全规章

- ▶ **使用随工具提供的辅助手柄。** 操作失手会引起人身伤害。
- ▶ **当在钻削附件可能触及暗线或其自身软线之处进行操作时，要通过绝缘握持面来握持工具。** 钻削附件碰到带电导线会使工具外露的金属零件带电从而使操作者受到电击。
- ▶ **使用合适的侦测装置侦察隐藏的电线，或者向当地的相关单位寻求支援。** 接触电线可能引起火灾并让操作者触电。损坏了瓦斯管会引起爆炸。凿穿水管不仅会造成严重的财物损失，也可能导致触电。

## 4 | 中文

- ▶ **如果安装在机器上的工具被夹住了，必须马上关闭电动工具并保持镇静。此时机器会产生极高的反应力矩，并进而造成回击。** 安装在机器上的工具容易被夹住如果：
  - 电动工具超荷了，或者
  - 安装在机器上的工具在工件中歪斜了。
- ▶ **务必握紧电动工具。** 在拧紧和放松螺丝时，可能出现短暂的大反击。
- ▶ **固定好工件。** 使用固定装置或老虎钳固定工件，会比用手持握工件更牢固。
- ▶ **等待电动工具完全静止后才能够放下机器。** 机器上的工具可能在工作中被夹住，而令您无法控制电动工具。

## 产品和功率描述



阅读所有的警告提示和指示。如未确实遵循警告提示和指示，可能导致电击，火灾并且 / 其他的严重伤害。

## 按照规定使用机器

本电动工具可以在木材，金属，陶瓷和塑料上钻孔。配备电子调节装置和正 / 逆转开关的机器也可以拧入 / 拧出螺丝或攻丝。

## 插图上的机件

机件的编号和电动工具详解图上的编号一致。

- 1 齿环夹头
- 2 起停开关的锁紧键
- 3 起停开关
- 4 正逆转开关
- 5 手柄（绝缘握柄）
- 6 夹头扳手
- 7 螺丝批嘴\*
- 8 通用批嘴连杆\*

\*图表或说明上提到的附件，并不包含在基本的供货范围中。本公司的附件清单中有完整的附件供应项目。

## 技术数据

电钻		TBM 3500
物品代码		3 601 AA9 0..
额定输入功率	瓦	350
输出功率	瓦	160
无负载转速	次 / 分	0 - 2800
额定转速	次 / 分	0 - 2000
转速控制装置		●
正 / 逆转功能		●

本说明书提供的参数是以 230 V 为依据，于低电压地区，此数据有可能不同。

电钻		TBM 3500
夹头的夹紧范围	毫米	1 - 10
最大钻孔直径		
- 钢	毫米	10
- 木材	毫米	20
- 铝	毫米	13
重量符合 EPTA-Procedure 01:2014	公斤	1,2
绝缘等级		□/II

本说明书提供的参数是以 230 V 为依据，于低电压地区，此数据有可能不同。

## 安装

## 更换工具（参考插图 A）

- ▶ **维修电动工具或换装零、配件之前，务必从插座上拔出插头。**

转动齿环夹头 1 至能够装入工具为止，安装好工具。把夹头扳手 6 插入夹头 1 上的收紧孔中，并正确地夹紧工具。

## 起子机的工具（参考插图 B）

以螺丝批嘴 7 作业时，一定要使用通用批嘴连杆 8。只能选用能够配合螺丝头的螺丝批嘴。

## 更换夹头

如果电动工具没有主轴锁定功能，必须把机器交给经过授权的博世电动工具顾客服务处更换夹头。

**使用约 25 - 30 牛顿米的拉紧扭力拧紧夹头。**



## 吸锯尘 / 吸锯屑

- ▶ 含铅的颜料以及某些木材、矿物和金属的加工废尘有害健康。机器操作者或者工地附近的人如果接触、吸入这些废尘，可能会有过敏反应或者感染呼吸道疾病。

某些尘埃（例如加工橡木或山毛榉的废尘）可能致癌，特别是和处理木材的添加剂（例如木材的防腐剂等）结合之后。只有经过专业训练的人才能够加工含石棉的物料。

- 工作场所要保持空气流通。
- 最好佩戴 P2 滤网等级的口罩。

请留心并遵守贵国和加工物料有关的法规。

- ▶ **避免让工作场所堆积过多的尘垢。** 尘埃容易被点燃。

## 操作

### 操作机器

- ▶ **注意电源的电压！** 电源的电压必须和电动工具铭牌上标示的电压一致。

### 改变转向

- ▶ **在电动工具完全静止时才可以**使用正逆转开关 4。

使用正逆转开关 4 可以改变机器的转向。如果按住了起停开关 3，则无法改变转向。

**正转：**适用于正常钻和转紧螺丝时，把正逆转开关 4 向左推到底。

**逆转：**适用于放松 / 转出螺丝和螺母，把正逆转开关 4 向右推到底。

### 开动 / 关闭

**操作**电动工具时先按下电动工具的起停开关 3，并持续按着。

按下锁紧键 2 即可**锁定**被按住的起停开关 3。

放开起停开关 3 便可以**关闭**电动工具。

为了节约能源，只在当您使用机器时，才开动电动工具。

### 调整转速

你可以无级式调整转速，把起停开关 3 按得越紧，转速就越快。

轻按起停开关 3 机器以低转速运转。逐渐在开关上加压，转速也会跟着提高。

### 有关操作方式的指点

- ▶ **维修电动工具或换装零、配件之前，务必从插座上拔出插头。**
- ▶ **先关闭电动工具，然后再把工具放置在螺母 / 螺丝上。** 安装在接头上的工具如果仍继续转动，容易从螺丝头上滑开。

### 建议

在机器以低转速长期运作之后，可让机器在空载的状况下，以最高转速旋转 3 分钟，以加速冷却。

在金属上钻孔时只能使用完好，经过研磨的 HSS 钻头（HSS = 高效率高速钢）。在博世的附件产品系列中，有符合 这个品质等级的产品。

把大的、长的螺丝拧入坚硬的物料中之前，必须根据螺纹的中心直径打预钻孔，预钻孔的深度大概为螺丝长度的  $\frac{2}{3}$ 。

## 维修和服务

### 维修和清洁

- ▶ **维修电动工具或换装零、配件之前，务必从插座上拔出插头。**
- ▶ **电动工具和通风间隙都必须保持清洁，这样才能够提高工作品质和安全性。**

如果必须更换连接线，务必把这项工作交给博世或者经授权的博世电动工具顾客服务执行，以避免危害机器的安全性能。

### 顾客服务处和顾客咨询中心

本公司顾客服务处负责回答有关本公司产品的修理、维护和备件的问题。以下的网页中有爆炸图和备件的资料：

[www.bosch-pt.com](http://www.bosch-pt.com)

博世顾客咨询团队非常乐意为您解答有关本公司产品及附件的问题。

询问和订购备件时，务必提供机器铭牌上标示的 10 位数物品代码。

有关保证，维修或更换零件事宜，请向合格的经销商查询。

### 中国大陆

博世电动工具（中国）有限公司

中国 浙江省 杭州市

滨江区滨康路 567 号

邮政编码：310052

免费服务热线：4008268484

传真：(0571) 87774502

电邮：[contact.ptcn@cn.bosch.com](mailto:contact.ptcn@cn.bosch.com)

[www.bosch-pt.com.cn](http://www.bosch-pt.com.cn)

罗伯特·博世有限公司

香港北角英皇道 625 号 21 楼

客户服务热线：+852 2101 0235

传真：+852 2590 9762

电邮：[info@hk.bosch.com](mailto:info@hk.bosch.com)

网站：[www.bosch-pt.com.hk](http://www.bosch-pt.com.hk)

### 制造商地址：

Robert Bosch Power Tools GmbH

罗伯特·博世电动工具有限公司

70538 Stuttgart / GERMANY

70538 斯图加特 / 德国

### 处理废弃物

必须以符合环保的方式，回收再利用损坏的机器、附件和废弃的包装材料。

不可以把电动工具丢入家庭垃圾中！

### 保留修改权。



1 612 025 031

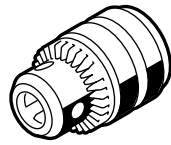

1 608 571 053

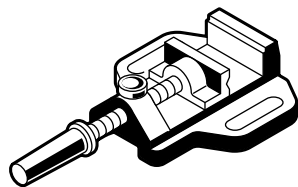

2 608 030 053 (MS 65)  
2 608 030 054 (MS 75)  
2 608 030 055 (MS 80)

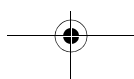
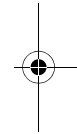
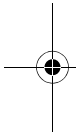



**以下各页勿打印！**

***Following pages  
are NOT for printing!***

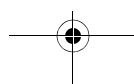
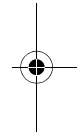
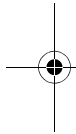

2 | English

## English

### Safety Notes

#### General Power Tool Safety Warnings

**⚠ WARNING** Read all safety warnings and all instructions. Failure to follow the warnings and instructions may result in electric shock, fire and/or serious injury.

**Save all warnings and instructions for future reference.**

The term "power tool" in the warnings refers to your mains-operated (corded) power tool or battery-operated (cordless) power tool.

#### Work area safety

- ▶ **Keep work area clean and well lit.** Cluttered or dark areas invite accidents.
- ▶ **Do not operate power tools in explosive atmospheres, such as in the presence of flammable liquids, gases or dust.** Power tools create sparks which may ignite the dust or fumes.
- ▶ **Keep children and bystanders away while operating a power tool.** Distractions can cause you to lose control.

#### Electrical safety

- ▶ **Power tool plugs must match the outlet. Never modify the plug in any way. Do not use any adapter plugs with earthed (grounded) power tools.** Unmodified plugs and matching outlets will reduce risk of electric shock.
- ▶ **Avoid body contact with earthed or grounded surfaces, such as pipes, radiators, ranges and refrigerators.** There is an increased risk of electric shock if your body is earthed or grounded.
- ▶ **Do not expose power tools to rain or wet conditions.** Water entering a power tool will increase the risk of electric shock.
- ▶ **Do not abuse the cord. Never use the cord for carrying, pulling or unplugging the power tool. Keep cord away from heat, oil, sharp edges and moving parts.** Damaged or entangled cords increase the risk of electric shock.
- ▶ **When operating a power tool outdoors, use an extension cord suitable for outdoor use.** Use of a cord suitable for outdoor use reduces the risk of electric shock.
- ▶ **If operating a power tool in a damp location is unavoidable, use a residual current device (RCD) protected supply.** Use of an RCD reduces the risk of electric shock.

#### Personal safety

- ▶ **Stay alert, watch what you are doing and use common sense when operating a power tool. Do not use a power tool while you are tired or under the influence of drugs, alcohol or medication.** A moment of inattention while operating power tools may result in serious personal injury.
- ▶ **Use personal protective equipment. Always wear eye protection.** Protective equipment such as dust mask, non-skid safety shoes, hard hat, or hearing protection used for appropriate conditions will reduce personal injuries.

- ▶ **Prevent unintentional starting. Ensure the switch is in the off-position before connecting to power source and/or battery pack, picking up or carrying the tool.** Carrying power tools with your finger on the switch or energising power tools that have the switch on invites accidents.
- ▶ **Remove any adjusting key or wrench before turning the power tool on.** A wrench or a key left attached to a rotating part of the power tool may result in personal injury.
- ▶ **Do not overreach. Keep proper footing and balance at all times.** This enables better control of the power tool in unexpected situations.
- ▶ **Dress properly. Do not wear loose clothing or jewellery. Keep your hair, clothing and gloves away from moving parts.** Loose clothes, jewellery or long hair can be caught in moving parts.
- ▶ **If devices are provided for the connection of dust extraction and collection facilities, ensure these are connected and properly used.** Use of dust collection can reduce dust-related hazards.

#### Power tool use and care

- ▶ **Do not force the power tool. Use the correct power tool for your application.** The correct power tool will do the job better and safer at the rate for which it was designed.
- ▶ **Do not use the power tool if the switch does not turn it on and off.** Any power tool that cannot be controlled with the switch is dangerous and must be repaired.
- ▶ **Disconnect the plug from the power source and/or the battery pack from the power tool before making any adjustments, changing accessories, or storing power tools.** Such preventive safety measures reduce the risk of starting the power tool accidentally.
- ▶ **Store idle power tools out of the reach of children and do not allow persons unfamiliar with the power tool or these instructions to operate the power tool.** Power tools are dangerous in the hands of untrained users.
- ▶ **Maintain power tools. Check for misalignment or binding of moving parts, breakage of parts and any other condition that may affect the power tool's operation. If damaged, have the power tool repaired before use.** Many accidents are caused by poorly maintained power tools.
- ▶ **Keep cutting tools sharp and clean.** Properly maintained cutting tools with sharp cutting edges are less likely to bind and are easier to control.
- ▶ **Use the power tool, accessories and tool bits etc. in accordance with these instructions, taking into account the working conditions and the work to be performed.** Use of the power tool for operations different from those intended could result in a hazardous situation.

#### Service

- ▶ **Have your power tool serviced by a qualified repair person using only identical replacement parts.** This will ensure that the safety of the power tool is maintained.



### Safety Warnings for Drills

- ▶ **Use auxiliary handle(s), if supplied with the tool.** Loss of control can cause personal injury.
- ▶ **Hold power tool by insulated gripping surfaces, when performing an operation where the cutting accessory may contact hidden wiring or its own cord.** Cutting accessory contacting a "live" wire may make exposed metal parts of the power tool "live" and could give the operator an electric shock.
- ▶ **Use suitable detectors to determine if utility lines are hidden in the work area or call the local utility company for assistance.** Contact with electric lines can lead to fire and electric shock. Damaging a gas line can lead to explosion. Penetrating a water line causes property damage or may cause an electric shock.
- ▶ **Switch off the power tool immediately when the tool insert jams. Be prepared for high reaction torque that can cause kickback.** The tool insert jams when:
  - the power tool is subject to overload or
  - it becomes wedged in the workpiece.
- ▶ **Hold the machine with a firm grip.** High reaction torque can briefly occur while driving in and loosening screws.
- ▶ **Secure the workpiece.** A workpiece clamped with clamping devices or in a vice is held more secure than by hand.
- ▶ **Always wait until the machine has come to a complete stop before placing it down.** The tool insert can jam and lead to loss of control over the power tool.

**Products sold in GB only:** Your product is fitted with a BS 1363/A approved electric plug with internal fuse (ASTA approved to BS 1362).

If the plug is not suitable for your socket outlets, it should be cut off and an appropriate plug fitted in its place by an authorised customer service agent. The replacement plug should have the same fuse rating as the original plug.

The severed plug must be disposed of to avoid a possible shock hazard and should never be inserted into a mains socket elsewhere.

**Products sold in AUS and NZ only:** Use a residual current device (RCD) with a rated residual current of 30 mA or less.

### Product Description and Specifications



**Read all safety warnings and all instructions.** Failure to follow the warnings and instructions may result in electric shock, fire and/or serious injury.

#### Intended Use

The machine is intended for drilling in wood, metal, ceramic and plastic. Machines with electronic control and right and left rotation are also suitable for screwdriving and tapping.

#### Product Features

The numbering of the product features refers to the illustration of the machine on the graphics page.

- 1 Key type drill chuck
- 2 Lock-on button for On/Off switch

- 3 On/Off switch
- 4 Rotational direction switch
- 5 Handle (insulated gripping surface)
- 6 Chuck key
- 7 Screwdriver bit\*
- 8 Universal bit holder\*

\*Accessories shown or described are not part of the standard delivery scope of the product. A complete overview of accessories can be found in our accessories program.

### Technical Data

Rotary drill	TBM 3500	
Article number		3 601 AA9 0..
Rated power input	W	350
Output power	W	160
No-load speed	min <sup>-1</sup>	0 – 2800
Rated speed	min <sup>-1</sup>	0 – 2000
Speed control		●
Right/left rotation		●
Chuck clamping range	mm	1 – 10
Max. drilling dia.		
– Steel	mm	10
– Wood	mm	20
– Aluminium	mm	13
Weight according to EPTA-Procedure 01:2014	kg	1.2
Protection class		□/II

The values given are valid for a nominal voltage [U] of 230 V. For different voltages and models for specific countries, these values can vary.

### Assembly

#### Changing the Tool (see figure A)

- ▶ **Before any work on the machine itself, pull the mains plug.**

Open the key type drill chuck **1** by turning until the tool can be inserted. Insert the tool.

Insert the chuck key **6** into the corresponding holes of the key type drill chuck **1** and clamp the tool uniformly.

#### Screwdriver Tools (see figure B)

When working with screwdriver bits **7**, a universal bit holder **8** should always be used. Use only screwdriver bits that fit the screw head.

#### Replacing the Drill Chuck

For machines without spindle lock, the drill chuck must be replaced through an authorized after-sales service agent for Bosch power tools.



**The drill chuck must be tightened with a tightening torque of approx. 25 – 30 Nm.**

## 4 | English

**Dust/Chip Extraction**

- ▶ Dusts from materials such as lead-containing coatings, some wood types, minerals and metal can be harmful to one's health. Touching or breathing-in the dusts can cause allergic reactions and/or lead to respiratory infections of the user or bystanders.

Certain dusts, such as oak or beech dust, are considered as carcinogenic, especially in connection with wood-treatment additives (chromate, wood preservative). Materials containing asbestos may only be worked by specialists.

- Provide for good ventilation of the working place.
- It is recommended to wear a P2 filter-class respirator.

Observe the relevant regulations in your country for the materials to be worked.

- ▶ **Prevent dust accumulation at the workplace.** Dusts can easily ignite.

**Operation****Starting Operation**

- ▶ **Observe correct mains voltage! The voltage of the power source must agree with the voltage specified on the nameplate of the machine. Power tools marked with 230 V can also be operated with 220 V.**

**Reversing the rotational direction**

- ▶ **Actuate the rotational direction switch 4 only when the machine is at a standstill.**

The rotational direction switch 4 is used to reverse the rotational direction of the machine. However, this is not possible with the On/Off switch 3 actuated.

**Right Rotation:** For drilling and driving in screws, push the rotational direction switch 4 left to the stop.

**Left Rotation:** For loosening and unscrewing screws and nuts, press the rotational direction switch 4 through to the right stop.

**Switching On and Off**

To **start** the machine, press the On/Off switch 3 and keep it pressed.

To lock the **pressed** On/Off switch 3, press the lock-on button 2.

To **switch off** the machine, release the On/Off switch 3.

To save energy, only switch the power tool on when using it.

**Adjusting the Speed**

The speed of the switched-on power tool can be variably adjusted, depending on how far the On/Off switch 3 is pressed.

Light pressure on the On/Off switch 3 results in a low rotational speed. Further pressure on the switch results in an increase in speed.

**Working Advice**

- ▶ **Before any work on the machine itself, pull the mains plug.**
- ▶ **Apply the power tool to the screw/nut only when it is switched off.** Rotating tool inserts can slip off.

**Tips**

After longer periods of working at low speed, allow the machine to cool down by running it for approx. 3 minutes at maximum speed with no load.

For drilling in metal, use only perfectly sharpened HSS drill bits (HSS = high-speed steel). The appropriate quality is guaranteed by the Bosch accessories program.

Before screwing larger, longer screws into hard materials, it is advisable to predrill a pilot hole with the core diameter of the thread to approx.  $\frac{2}{3}$  of the screw length.

**Maintenance and Service****Maintenance and Cleaning**

- ▶ **Before any work on the machine itself, pull the mains plug.**
- ▶ **For safe and proper working, always keep the machine and ventilation slots clean.**

If the replacement of the supply cord is necessary, this has to be done by Bosch or an authorized Bosch service agent in order to avoid a safety hazard.

**After-sales Service and Application Service**

Our after-sales service responds to your questions concerning maintenance and repair of your product as well as spare parts. Exploded views and information on spare parts can also be found under:

**www.bosch-pt.com**

Bosch's application service team will gladly answer questions concerning our products and their accessories.

In all correspondence and spare parts order, please always include the 10-digit article number given on the type plate of the machine.

**People's Republic of China****China Mainland**

Bosch Power Tools (China) Co., Ltd.

567, Bin Kang Road

Bin Jiang District 310052

Hangzhou, P. R. China

Service Hotline: 4008268484

Fax: (0571) 87774502

E-Mail: contact.ptcn@cn.bosch.com

www.bosch-pt.com.cn

**HK and Macau Special Administrative Regions**

Robert Bosch Hong Kong Co. Ltd.  
21st Floor, 625 King's Road  
North Point, Hong Kong  
Customer Service Hotline: +852 2101 0235  
Fax: +852 2590 9762  
E-Mail: info@hk.bosch.com  
www.bosch-pt.com.hk

**Indonesia**

PT Robert Bosch  
Palma Tower 9<sup>th</sup> & 10<sup>th</sup> Floor  
Jl. Let. Jend. TB Simatupang II S/06  
Jakarta Selatan 12960  
Indonesia  
Tel.: (021) 3005 6565  
Fax: (021) 3005 5801  
E-Mail: boschpowertools@id.bosch.com  
www.bosch-pt.co.id

**Philippines**

Robert Bosch, Inc.  
28th Floor Fort Legend Towers,  
3rd Avenue corner 31st Street,  
Fort Bonifacio Global City,  
1634 Taguig City, Philippines  
Tel.: (02) 8703871  
Fax: (02) 8703870  
matheus.contiero@ph.bosch.com  
www.bosch-pt.com.ph

Bosch Service Center:  
9725-27 Kamagong Street  
San Antonio Village  
Makati City, Philippines  
Tel.: (02) 8999091  
Fax: (02) 8976432  
rosalie.dagdagan@ph.bosch.com

**Malaysia**

Robert Bosch (S.E.A.) Sdn. Bhd.  
No. 8A, Jalan 13/6  
G.P.O. Box 10818  
46200 Petaling Jaya  
Selangor, Malaysia  
Tel.: (03) 79663194  
Fax: (03) 79583838  
cheehoe.on@my.bosch.com  
Toll-Free: 1800 880188  
www.bosch-pt.com.my

**Thailand**

Robert Bosch Ltd.  
Liberty Square Building  
No. 287, 11 Floor  
Silom Road, Bangrak  
Bangkok 10500  
Tel.: 02 6393111, 02 6393118  
Fax: 02 2384783  
Robert Bosch Ltd., P. O. Box 2054  
Bangkok 10501, Thailand  
www.bosch.co.th

Bosch Service – Training Centre  
La Salle Tower Ground Floor Unit No.2  
10/11 La Salle Moo 16  
Srinakharin Road  
Bangkaew, Bang Plee  
Samutprakarn 10540  
Thailand  
Tel.: 02 7587555  
Fax: 02 7587525

**Singapore**

Robert Bosch (SEA) Pte. Ltd.  
11 Bishan Street 21  
Singapore 573943  
Tel.: 6571 2772  
Fax: 6350 5315  
leongheng.leow@sg.bosch.com  
Toll-Free: 1800 3338333  
www.bosch-pt.com.sg

**Vietnam**

Robert Bosch Vietnam Co. Ltd  
10/F, 194 Golden Building  
473 Dien Bien Phu Street  
Ward 25, Binh Thanh District  
84 Ho Chi Minh City  
Vietnam  
Tel.: (08) 6258 3690 ext. 413  
Fax: (08) 6258 3692  
hieu.lagia@vn.bosch.com  
www.bosch-pt.com

**Australia, New Zealand and Pacific Islands**

Robert Bosch Australia Pty. Ltd.  
Power Tools  
Locked Bag 66  
Clayton South VIC 3169  
Customer Contact Center  
Inside Australia:  
Phone: (01300) 307044  
Fax: (01300) 307045  
Inside New Zealand:  
Phone: (0800) 543353  
Fax: (0800) 428570  
Outside AU and NZ:  
Phone: +61 3 95415555  
www.bosch.com.au

**Disposal**

The machine, accessories and packaging should be sorted for environmental-friendly recycling.

Do not dispose of power tools into household waste!

**Subject to change without notice.**