



湖南艾华集团股份有限公司

HUNAN AIHUA GROUP CO., LTD

Tel: (0737)6184466 Fax : (0737)6180493

[Http://www.aihuaglobal.com](http://www.aihuaglobal.com)

SPECIFICATION

Description: Aluminum Electrolytic Capacitors

AISHI P/N: EGH1EM221F12OTGOS0

SERIES: GH

ITEM: 25V220 μ F (Φ 8 \times 12)

Customer P/N:

No.: CRS-JD-1711290

APPROVED BY

Please Return One Copy with Your Approval
承认后请寄回一份

PREPARED BY	CHECKED BY	APPROVED BY
 <p>宋蕾 技术中心</p>	 <p>許雷冰 技术中心</p>	 <p>黃遠彬 技术中心</p>

<i>Starts</i>	<i>File</i>	<i>Description</i>	<i>Component</i>	<i>No./rev</i>
Released	Approval	Sheet-GH	CRS-2010-GH/	01

变更记录

版本	更改原因	更改内容	生效日期
CRS-JD-1711290	新建	新建	2017-11-24

Customer	深圳市仁天芯科技有限公司	SERIES	GH	DATE	2017-11-24
-----------------	--------------	---------------	----	-------------	------------

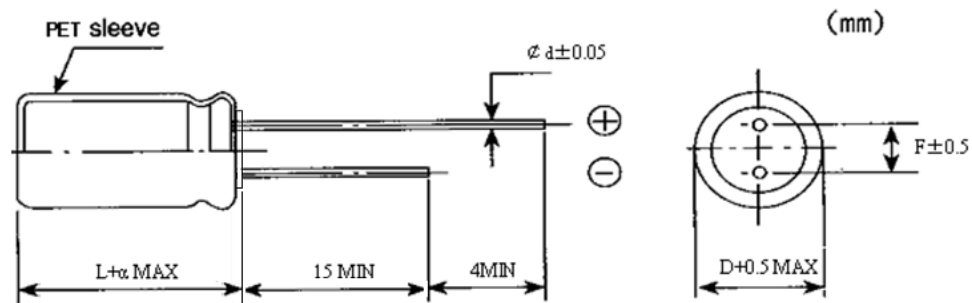

FIG-1

TABLE-1

No.	Customer Part No.	Aishi Part No.	Capacitance (μF)	Tolerance on Rated Capacitance (%)	Rated Voltage (Vdc)	Surge Voltage (Vdc)	Operating Temp. Range (°C)	tanδ (120Hz) (Max)	Leakage Current (μA)(2min.)	Max Ripple Current (mArms) at 105°C 100kHz	ESR (Ω) at 20°C, 100kHz	Endurance at 105°C (Hours)	Dimensions (mm)					Appearance Drawing No.
													Φ	L	α	d	F	
1		EGH1EM221F12OTGOS0	220	±20	25	32	-40~+105	0.18	55	210	0.46	7000	8	12	2	0.6	3.5	FIG-1

注：料号第 15 码“G”表示橡胶塞特殊要求，第 16 码“O”表示 CP 线特殊要求，料号第 17、18 码“S0”表示套管体现容量偏差代码的要求。

Starts	File	Description	Component	No./rev
Released	Approval	Sheet-GH	CRS-2010-GH/ 01	

1 概述 SCOPE

本承认书规定了 GH 系列径向引线引出铝电解电容器的技术规范, 本技术规范条文解释权归本公司所有。

This specification covers “GH series” miniature single-ended aluminum electrolytic capacitors, Aishi reserves the right of final interpretation for this technical specification.

2 参考标准 APPLICABLE SPECIFICATION

本承认书参考 GB/T2693-2001、GB/T5993-2003、GB/17215.211-2006、GB/T2423.32-2008 和 GB/T2423.28-2005 制定。

This approval sheet consulted the institute of GB/T2693-2001 、 GB/T5993-2003 、 GB/17215.211-2006、GB/T2423.32-2008 and GB/T2423.28-2005。

3 基本要求 Basic requirements.

3.1 温度范围 OPERATING TEMPERATURE RANGE

表 1 环境温度范围 (°C)

Table1 Ambient Temperature Range (°C)

No.	条件 Condition	温度 Temperature
1	规定的使用温度 Operating temperature	-40~105
2	极限使用温度 Limiting operating temperature	-55~105
3	贮存温度 Storage temperature	-40~105

3.2 湿度范围 HUMIDITY RANGE

表 2 空气相对湿度

Table 2 Relative Humidity

No.	条件 Condition	湿度 Humidity
1	年平均 annual average	<75%
2	30 个自然日/年 30 natural days / year	95%
3	在其它天偶然出现 By accident on other days	85%

3.3 大气压力 Air pressure

63.0kPa~106.0kPa (海拔 4000m 及以下), 特殊订货要求除外。高海拔地区, 电解电容器满足在海拔 4000m~4700m 正常工作的要求。

63.0kPa~106.0kPa (altitude: ≤4000m), exclude special requirement. For high-altitude areas, aluminum electrolytic capacitors can operate normally even in regions with the altitude of 4000m~4700m.

Name	Approval Sheet-GH				
File No.	GH	Version	01	Page	1
STANDARD MANUAL					

Starts	File	Description	Component	No./rev
Released	Approval	Sheet-GH	CRS-2010-GH/ 01	

4. 测试环境 CONDITION OF TEST

如果没有其他规定，标准的测试、检验环境条件如下所示：

环境温度：15℃~25℃

相对湿度：30%~70%

大气压力：86kPa~106kPa

如果对测试结果有异议，可以在以下条件测试：

环境温度：20℃±1℃

相对湿度：60%~67%

大气压力：86kPa~106kPa

Unless otherwise specified, the standard range of atmospheric conditions for making measurements and tests are as follows

Ambient temperature : 15℃ to 25℃

Relative humidity : 30% to 70%

Air pressure : 86kPa to 106kPa

If there may be doubt on the results, measurements shall be made within the following limits

Ambient temperature : 20±1℃

Relative humidity : 60% to 67%

Air pressure : 86kPa to 106kPa

Name	Approval Sheet-GH			
File No.	GH	Version	01	Page 2
STANDARD MANUAL				

<i>Starts</i>	<i>File Description</i>	<i>Component</i>	<i>No./rev</i>
Released	Approval Sheet-GH	CRS-2010-GH/ 01	

5. 产品特性 PRODUCT CHARACTERISTICS

5.1 电气特性 ELECTRICAL CHARACTERISTICS

序号 No.	项目 Item	测试方法 Test method	性能 Performance
5.1.1	额定工作电压 Rated voltage	电压：直流电压值+交流电压峰值≤额定电压 Voltage: DC. Voltage + peak ripple voltage ≤ Rated voltage	6.3V.DC~450V.DC
5.1.2	电容量 Capacitance	测试频率：120Hz(±20%) 测试电路：串联等效 测试电压：0.5Vrms 以下+1.5~ 2.0VDC Measuring frequency: 120Hz±20% Measuring circuit: Series equivalent circuit Measuring voltage: 0.5Vrms or less +1.5 to 2.0 VDC	容量范围：1μF ~18000μF 容量偏差：-20%~+20% Range of Capacitance: 1μF ~18000μF Capacitance tolerance: -20%~+20%
5.1.3	损耗角正切值 Dissipation Factor	参照 GB/T5993-2003 中 4.3.3 的方法，施加频率为 120Hz、最大为 0.5V 交流有效值或不超过额定纹波电流要求的较低电压施加在被试样品上。 According to the method of 4.3.3 in GB/T5993-2003, apply the maximum 0.5V AC RMS voltage at 120Hz or a low voltage (not exceeding the rated ripple current requirement) to the sample capacitor.	不超过规定值 Not more than the specified value
5.1.4	等效串联电阻和 阻抗 ESR and Z	参照 GB/T2693-2001 中 4.8.2 的方法施加频率为 100kHz、最大为 0.5V 交流有效值或不超过额定纹波电流要求的较低电压施加在被试样品上。 According to the method of 4.8.2 in GB/T2693-2001, apply the maximum 0.5V AC RMS voltage at 100Hz or a low voltage (not exceeding the rated ripple current requirement) to the sample capacitor.	不超过规定值 Not more than the specified value

Name	Approval Sheet-GH			
File No.	GH	Version	01	Page 3
STANDARD MANUAL				

Starts	File Description		Component No./rev
Released	Approval Sheet-GH		CRS-2010-GH/ 01
5.1.5	绝缘外套的绝缘电阻 Insulation resistance of insulated sleeve	<p>参照 GB/T5993-2003 中的 4.3.5 方法，把一条金属箔紧紧缠在电解电容器本体整个长度上，金属箔与电解电容器引出端之间的间隙不小于 0.5mm。金属箔从两端至少各伸出 5mm,电解电容器两端的箔不得折向电解电容器的端部。将 100V±5V 的直流电压施加在金属箔与电解电容器相连的引线上，保持 1min，测量绝缘电阻。</p> <p>Refer to the method 4.3.5 in GB/T5993-2003; tightly wrap a metal foil around the capacitor body, leaving a 5mm length on both ends of the capacitor and keep 0.5mm distance from the terminals. The foil on both ends of the electrolytic capacitor shall not be folded into the terminals. After applying 100V + 5V of the DC voltage to the metal foil and the lead wires for 1min, measure the insulation resistance.</p>	<p>不低于 100 MΩ。 Not less than 100 MΩ.</p>
5.1.6	漏电流 Leakage current	<p>在电容器两端施加额定工作电压，并串联 1000±100Ω 电阻，在施加电压 2 分钟后，测量漏电流。 测试电路如下图：</p> <p>The rated voltage shall be applied across the capacitor and its protective resistor which shall be 1000±100Ω. The leakage current shall then be measured after an electrification period of 2 min..</p> <p>Measurement circuit</p> <p>Rs: Protective resistor(1000±100Ω) DC ammeter DC voltmeter S1: Switch S2: Protective switch for an ammeter</p>	<p>6.3V~100V: CV≤1000 I≤0.01CV 或 3μA, 取较大值 (2 分钟后) ; 6.3V~100V: CV≤1000 I≤0.01CV 或 3μA Whichever is greater (after 2 min) CV>1000 I≤0.006CV+4μA, (2 分钟后) CV>1000 I≤0.006CV+4μA, (after 2 min.)</p> <p>160V~450V: I≤0.01CV+10μA (2 分钟后) 160V~450V: I≤0.01CV+10μA (after 2 min.)</p> <p>I: 漏电流 (μA) C: 容量 (μF) V: 额定工作电压 (V) I: Leakage current(μA) C: Capacitance(μF) V: Rated voltage (V)</p>

Name	Approval Sheet-GH			
File No.	GH	Version	01	Page 4
STANDARD MANUAL				

Starts	File	Description	Component	No./rev												
Released	Approval	Sheet-GH	CRS-2010-GH/ 01													
5.1.7	温度特性 Temperature Characteristic	<table border="1"> <thead> <tr> <th>阶段 Step</th> <th>温度 Temperature</th> <th>时间 Time</th> </tr> </thead> <tbody> <tr> <td>1</td> <td>-40±3℃</td> <td>1h</td> </tr> <tr> <td>2</td> <td>20±2℃</td> <td>1h</td> </tr> <tr> <td>3</td> <td>105±2℃</td> <td>1h</td> </tr> </tbody> </table> <p>阶段 1: 将样品置于-40℃环境中 1h, 施加频率为 120Hz、最大为 0.5V 交流有效值或不超过额定纹波电流要求的较低电压施加在被试样品上, 测量电容量、阻抗。</p> <p>阶段 2: 将样品置于 20℃环境中 1h, 施加频率为 120Hz、最大为 0.5V 交流有效值或不超过额定纹波电流要求的较低电压施加在被试样品上, 测量电容量、阻抗。</p> <p>阶段 3: 将样品置于 105℃环境中 1h, 施加频率为 120Hz、最大为 0.5V 交流有效值或不超过额定纹波电流要求的较低电压施加在被试样品上, 测量电容量。</p> <p>容量比: 参照 GB/T5993-2003 中 4.3.2 的方法。</p> <p>阻抗比: 参照 GB/T2693-2001 中 4.10 的方法。</p> <p>Step 1: Place the sample in -40℃ for 1h, apply the maximum 0.5V AC RMS voltage at 120Hz or a low voltage (not exceeding the rated ripple current requirement) to it, then measure the capacitance and impedance.</p> <p>Step 2: place the sample in 20℃ for 1h, apply the maximum 0.5V AC RMS voltage at 120Hz or a low voltage (not exceeding the rated ripple current requirement) to it, then measure the capacitance and impedance. Calculate the ratio of the above capacitance values and Impedance values.</p> <p>Step 3: place the sample in 105℃ for 1h, apply the maximum 0.5V AC RMS voltage at 120Hz or a low voltage (not exceeding the rated ripple current requirement) to it, then measure the capacitance.</p> <p>Capacitance ratio: According to the method of 4.3.2 in GB/T5993-2003;</p> <p>Impedance ratio: According to the method of 4.10 in GB/T2693-2001;</p>	阶段 Step	温度 Temperature	时间 Time	1	-40±3℃	1h	2	20±2℃	1h	3	105±2℃	1h	<p>阶段 1: 阶段 1 电容量与阶段 2 容量变化率, 不超过 20%。</p> <p>阶段 2: 阶段 1 阻抗值与阶段 2 的阻抗比值, 满足表 3 规定值。</p> <p>阶段 3: 阶段 3 的容量变化率应在初始值 ±20%范围内。</p> <p>Step 1: Variation of capacitance in step 1 and 2: within ±20% of the initial value.</p> <p>Step 2: Impedance value in step 2 and that in step 1 shall not exceed the value given in table-3.</p> <p>Step 3: Variation of capacitance in step 3: within ±20% of the initial value.</p>	
阶段 Step	温度 Temperature	时间 Time														
1	-40±3℃	1h														
2	20±2℃	1h														
3	105±2℃	1h														

Name	Approval Sheet-GH			
File No.	GH	Version	01	Page 5
STANDARD MANUAL				

Starts	File	Description	Component	No./rev
Released	Approval	Sheet-GH	CRS-2010-GH/ 01	
5.1.8	耐浪涌电压 Surge Test	<p>参照 GB/T5993-2003 中 4.14 的方法对于额定电压小于或等于 315V 施加浪涌电压为额定电压的 1.15 倍, 对于额定电压大于 315V 施加浪涌电压为额定电压的 1.10 倍。</p> <p>电解电容器通过串联的电阻施加浪涌电压及放电, 充电与放电时所串联的电阻阻值为 1000Ω, 充电(施加浪涌电压) 30s±5s, 放电 330s±25s, 重复 1000 次, 然后电解电容器在大气条件下恢复 1h~2h 后测量电容量、漏电流、损耗角正切。试验温度为电解电容器的上限类别温度值。</p> <p>Refer to test method in 4.14 of GB/T5993-2003, for surge voltage, apply 1.15 times the rated voltage for those whose rated voltage ≤315V, If the rated voltage exceeds 315V, the surge voltage applied shall be 1.10 times of the rated voltage.</p> <p>The electrolytic capacitor is charged and discharged through series-wound resistor with resistance value of 1000Ω. After subjecting to 1000 cycles each consisting of charge (with surge voltage) for 30±5sec., and discharge for 330s±25s, restore the capacitor in standard atmospheric conditions for 1h to 2h, then measure the capacitance, LC and dissipation factor. Test temperature refers to the upper category temperature.</p>	<p>容量变化: 在初始值的±10%以内。 损耗角正切值不超过规定值的 150%。 漏电流: 不超过中规定值的 120% 外观: 无可见损伤。</p> <p>Capacitance change: Within ±10% of the initial value. Dissipation factor: Not more than 150% of the specified value . Leakage current: Not more than 120% of the specified value Appearance: No visible damage.</p>	
		<p>Test circuit</p> <p>Note: This requirement is applicable only to instantaneous over voltage which may be applied to terminals of capacitor, therefore, not applicable to such over voltages as often applied.</p>		
5.1.9	额定纹波 电流试验 Rated ripple current test	<p>将电解电容器置于规定的上限类别温度条件下, 按照试验条件施加规定频率的额定纹波电流, 持续 1000h, 不同频率纹波电流换算系数见第 7 点纹波电流频率因子。</p> <p>Put electrolytic capacitor under upper category temperature conditions; apply rated ripple current for 1000 h. See table 7 for frequency coefficient of rated ripple current.</p>	<p>容量变化: 在初始值的±20%以内。 损耗角正切值不超过规定值的 200%。 漏电流: 不超过规定值。 ESR: 不超过 300%的规定值。 外观: 无可见损伤</p> <p>Variation of capacitance: Within ±20% of the initial value. Dissipation factor: Not more than ±200% of the specified value Leakage current: Not more than the specified value ESR: Not more than ±300% of the specified value Appearance: No visible damage</p>	
Name	Approval Sheet-GH			
File No.	GH	Version	01	Page 6
STANDARD MANUAL				

Starts	File Description	Component No./rev
Released	Approval Sheet-GH	CRS-2010-GH/ 01

5.2 机械特性 MECHANICAL PERFORMANCE

序号 No.	项目 Item	测试方法 Test method	特性 Performance																								
5.2.1	端子强度 Terminal Strength	<p>端子抗拉强度： 沿电容器端子引线方向施加拉力(如下表)，10±1 秒。</p> <table border="1"> <tr> <td>引线直径 Φ</td> <td>0.45</td> <td>0.5</td> <td>0.6</td> <td>0.8</td> <td>1.0</td> </tr> <tr> <td>拉力 N</td> <td colspan="2">5</td> <td colspan="2">10</td> <td>20</td> </tr> </table> <p>端子抗弯强度： 在电容器引线施加固定重力（如下表），然后，将电容体弯折 90°后回到原位，再向相反方向弯折 90°后回到原位。 上述过程在 5 秒内完成。</p> <table border="1"> <tr> <td>引线直径 Φ</td> <td>0.45</td> <td>0.5</td> <td>0.6</td> <td>0.8</td> <td>1.0</td> </tr> <tr> <td>拉力 N</td> <td colspan="2">2.5</td> <td colspan="2">5</td> <td>10</td> </tr> </table> <p>Tensile strength of termination: A static load (stated in the table below) shall be applied to the terminal in the axial direction and acting in a direction away from the body for 10±1 sec. Bending strength of termination: Hang the specified dead weight (stated in the table below) , then bent the body through 90°, return to the original position. Next bent it in opposite direction through 90°with the same speed, again return to the original position. Carry out this operation in about 5 sec.</p>	引线直径 Φ	0.45	0.5	0.6	0.8	1.0	拉力 N	5		10		20	引线直径 Φ	0.45	0.5	0.6	0.8	1.0	拉力 N	2.5		5		10	<p>容量变化：在初始值的±5%以内。 测量电容器应无接触不良、开路或短路，无可见机械损伤。</p> <p>Variation of capacitance: Within ±5% of the initial value. When the capacitor is measured, there shall be no loose contacts, or open or short circuiting. There shall be no visible mechanical damage.</p>
引线直径 Φ	0.45	0.5	0.6	0.8	1.0																						
拉力 N	5		10		20																						
引线直径 Φ	0.45	0.5	0.6	0.8	1.0																						
拉力 N	2.5		5		10																						
5.2.2	振动试验 Resistance to Vibration	<p>依据 GB/17215.211-2006 中 5.2.2.3 进行振动试验。 电解电容器在使用时安装在电能表上，机械振动试验参照 GB/17215.211-2006 《交流电测量设备 通用要求、试验和试验条件 第 11 部分：测量设备》中机械振动的试验要求进行。 试验条件为： 频率范围：10Hz-150Hz 交越频率：60Hz f<60Hz，恒定振幅 0.075mm f>60Hz，恒定加速度 9.8m/ s² (1g) 每轴扫描周期数：10 注：10 个扫描周期-75min。 To comply with 5.2.2.3 of GB/17215.211-2006. Install electrolytic capacitors in the electric energy meter and follow the test requirement of mechanical vibration Test condition: Vibration Frequency Range : 10Hz-150Hz crossover frequency: 60Hz f<60Hz, uniform amplitude: 0.075mm f>60Hz, Constant acceleration: 9.8m/ s² (1g) Scanning cycles for every axis: 10 Note: 10 Scanning cycles-75min.</p>	<p>容量变化：在初始值的±5%以内。 测量电容器应无接触不良开路或短路，无可见机械损伤。</p> <p>Variation of capacitance: Within ±5% of the initial value. When the capacitor is measured there shall be no intermittent contacts, or open or short circuiting There shall be no such mechanical damage.</p>																								

Name	Approval Sheet-GH				
File No.	GH	Version	01	Page	7
STANDARD MANUAL					

Starts		File	Description	Component	No./rev
Released		Approval Sheet-GH		CRS-2010-GH/ 01	
5.2.3	可焊性 Solderability	<p>依据 GB/T2423.32-2008 的试验方法，对于含铅焊料，试验前和试验中的焊料温度为 (235±3) °C；对于无铅焊料，除非相关标准有相反规定，Sn96.5Ag3.0Cu0.5 焊料的温度为 (245±3) °C，Sn99.3Cu0.7 焊料的温度为 (250±3) °C。将电解电容器以 (5±1) mm/s~ (20±1) mm/s 的速度浸入熔融焊料中至规定的深度，并保持 5s，然后取出。测试电解电容器润湿力。</p> <p>According to test method in GB/T2423.32-2008, for leaded solder, the temperature before and during the test shall be (235±3) °C; for lead-free solder, unless there is relevant regulations, the temperature for solder(Sn96.5Ag3.0Cu0.5) shall be (245±3) °C, solder (Sn99.3Cu0.7) shall be (250±3) °C.</p> <p>Immerse the electrolytic capacitors into the molten solder to the specified depth at the rate of (5±1) mm/s~ (20±1) mm/s for 5 sec. and then take them out. Measure the wetting power of electrolytic capacitor.</p>		<p>润湿力不低于理论润湿力的 90%。 Wetting power shall not be less than 90% of the theoretical wetting power.</p>	

Name	Approval Sheet-GH				
File No.	GH	Version	01	Page	8
STANDARD MANUAL					

<i>Starts</i>	<i>File Description</i>	<i>Component</i>	<i>No./rev</i>
Released	Approval Sheet-GH	CRS-2010-GH/ 01	

5.3 耐久性测试 ENDURANCE PERFORMANCE

序号 No.	项目 Item	测试方法 Test method	特性 Performance
5.3.1	耐焊接热 Resistance to soldering heat	焊槽法： 焊锡温度：260±5℃ 浸入时间：5±1 秒 电路板：1.6mm Solder bath method Solder bath temperature：260±5℃ Immersion time：5±1sec. Printed wiring board: 1.6mm	容量变化：在初始值 5%范围内 外观：无可见损伤 Variation of capacitance: Within ±5% of the initial value Appearance: No visible damage
5.3.2	稳态湿热 Resistance to damp heat (steady state)	试验温度：40±2℃ 试验时间：240±8h 相对湿度：90~95% 试验后，电容器在标准大气条件下 1~2 小时，然后测试参数 To comply with JIS C 5101-1 4.22 Test temperature：40±2℃ Test time：240±8h Relative humidity: 90~95% After completion of test, the capacitor shall be subjected to standard atmospheric conditions for 1 to 2 hours, after which measurements shall be made.	容量变化：在初始值±10%范围内 损耗角正切值：不超过规定值 漏电流：不超过规定值 外观：无可见损伤 Variation of capacitance: Within ±10% of the initial value. Dissipation factor: Not more than the specified value Leakage current: Not more than the specified value Appearance: No visible damage
5.3.3	高温负荷试验 Load Life Test	电解电容器进行 GB/T2693-2001 中 4.23 的寿命试验，进行 105℃高温并施加额定电压 5000h 的耐久性试验，试验结束后在常温下静置 16h 进行电气试验。 Refer to test method in 4.23 of GB/T 2693-2001. Apply rated voltage for 5,000 hours at 105°C. Conduct electrical test after the capacitors are restored for 16h.	容量变化：在初始值±20%范围内 损耗角正切值：不超过规定值的 200% 漏电流：不超过规定值 ESR：不超过规定值的 300% 外观：无可见损伤 Variation of capacitance: Within ±20% of the initial value. Dissipation factor: Not more than 200% of the specified value Leakage current: Not more than the specified value ESR: Not more than 300% of the specified value Appearance: No visible damage.

Name	Approval Sheet-GH				
File No.	GH	Version	01	Page	9
STANDARD MANUAL					

Starts		File	Description	Component	No./rev
Released		Approval Sheet-GH		CRS-2010-GH/ 01	
5.3.4	高温贮存试验 Storage at high temperature	参考 GB/T5993-2003 中 4.17 的方法电解电容器应进行 105℃±2 高温 96h 的贮存, 试验结束后在常温下静置 4h 进行电气试验。 Refer to test method in 4.17 of GB/T 5993-2003. Store the capacitors at 105℃±2℃ for 96h. After recovery for 4h, the measurements prescribed in the relevant specification shall be made.		容量变化: 初始值±10%范围内 损耗角正切值: 不超过规定值的 150% 漏电流: 不超过规定值的 120% 外观: 无可见损伤 Variation of capacitance: Within ±10% of the initial value. Dissipation factor: Not more than 150% of the specified value; Leakage current: Not more than 120% of the specified value Appearance: No visible damage.	
5.3.5	低温贮存试验 Storage at low temperature	参考 GB/T5993-2003 中 4.18 的方法电解电容器应进行 -55℃±2 低温 96h 的贮存, 试验结束后在常温下静置 16h 进行电气试验。 Refer to test method in 4.18 of GB/T 5993-2003. Store the capacitors at -55℃±2℃ for 96h. Conduct electrical test after the capacitors are restored for 16h.		容量变化: 初始值±10%范围内 损耗角正切值: 不超过规定值的 150% 漏电流: 不超过规定值的 120% 外观: 无可见损伤 Variation of capacitance: Within ±20% of the value before test. (6.3V,10V: ≤±30%) Dissipation factor: Not more than 200% of the specified value Leakage current: Not more than 200% of the specified value Appearance: No visible damage.	
5.3.6	高温高湿 贮存试验 High temperature and high humidity storage test	参考 GB/T2693-2001 中 4.22 的试验方法电解电容器应进行 85℃±2 高温、85%RH 湿度 96h 的贮存, 试验结束后在常温下静置 4h 进行电气试验。 Refer to test method in 4.22 of GB/T2693-2001. Store the capacitors under a relative humidity of 85% at 85℃±2℃ for 96h. Conduct electrical test after the capacitors are restored for 4h.		容量变化: 初始值±10%范围内 损耗角正切值: 不超过规定值的 150% 漏电流: 不超过规定值的 120% 外观: 无可见损伤 Variation of capacitance: Within ±10% of the initial value; Dissipation factor: Not more than 150% of the specified value Leakage current: Not more than 120% of the specified value Appearance: No visible damage.	
5.3.7	温度冲击实验 Thermal shock test	低温: -40℃持续 30min 高温: 85℃持续 30min 温度转换时间: 2min-3min 循环周期数: 5 实验后恢复 16H 进行电气试验。 Low temperature: 30min at -40℃; High temperature: 30min at 85℃; Temperature switching time: 2min-3min Cycle time: 5 Conduct electrical test after the capacitors are restored for 16h.		容量变化: 初始值±10%范围内 损耗角正切值: 不超过规定值的 150% 漏电流: 不超过规定值的 120% 外观: 无可见损伤 Variation of capacitance: Within ±10% of the initial value; Dissipation factor: Not more than 150% of the specified value Leakage current: Not more than 120% of the specified value Appearance: No visible damage.	
Name		Approval Sheet-GH			
File No.		GH	Version	01	Page 10
STANDARD MANUAL					

Starts		File	Description	Component	No./rev
Released		Approval Sheet-GH		CRS-2010-GH/ 01	
5.3.8	防爆试验 Safety Vent	以下试验只适用于铝壳直径 $\geq\Phi 8$ 产品。 The following tests only apply to those products with vent products at diameter $\geq\Phi 8$ with vent. 在电容器两极施加反向直流电压，其中通过的电流为 1 A，在测试时防爆装置应能在 30 分钟内动作。 D. C. Application test The capacitor shall be subjected to a reverse D.C. voltage The current flowing through the capacitor shall be 1A. If the vent does operate with the voltage applied for 30 minutes, the test is considered to be passed.		上述过程中应无引线、铝箔等散射，无火花产生。 The vent device is actuated under the test conditions, thereby preventing terminals, metal pieces, etc, of the capacitor from scattering due to burst, the case from separating from the seal packing, or the capacitor from producing flame.	

※ 表 3 (TABLE 3)

阻抗比	额定工作电压	6.3	10	16	25	35	50	63	100	160	200~450
Max. Impedance Ratio	Rated voltage (v)										
	z -40°C/ z 20°C	7	5		4				7		

Name	Approval Sheet-GH				
File No.	GH	Version	01	Page	11
STANDARD MANUAL					

Starts	File	Description	Component	No./rev
Released	Approval	Sheet-GH	CRS-2010-GH/ 01	

6. 标记 MARKING

6.1 在电容器体上应注明如下内容:

- (1) 生产厂商商标
- (2) 型号-额定温度 GH 105°C
- (3) 周期代码-我司代码-套管材质 YyWwJ PET (Yy 表示年份, Ww 表示制造周期, M 表示容差代码, PET 表示套管材质)
- (4) 电压容量 --V- - μ F
- (5) 负极标志
- (6) 容量偏差代码

6.1The following items shall be marked indelibly on the capacitor.

- (1) Manufacture’s name or trade mark.
- (2) Model - Rated temperature GH 105°C
- (3) Cycle code- AIHUA code -Sleeve material YyWwJ PET (Yy denotes last two digit of years and Ww denotes the week in which the capacitor is Manufactured, M denote capacitance tolerance code, PET denotes the sleeve material)
- (4) Voltage Capacity --V- - μ F
- (5) Polarity of the terminals
- (6) Capacitance tolerance code

6.2 标记颜色 Marking color

套管颜色: 棕色
 标记颜色: 白
 Sleeve color: Brown
 Marking color: White

7. 纹波电流频率因子 RIPPLE CURRENT FREQUENCY COEFFICIENT

Freq. (Hz)	50/60	100/120	1k	10k	100k
Cap.≤330	0.35	0.50	0.75	0.85	1.00
330<Cap.≤1500	0.45	0.65	0.85	0.90	1.00
1500<Cap.≤18000	0.53	0.75	0.90	0.95	1.00

Name	Approval Sheet-GH				
File No.	GH	Version	01	Page	12
STANDARD MANUAL					

Starts	File	Description	Component	No./rev
Released	Approval	Sheet-GH	CRS-2010-GH/ 01	

8. 物料编码 PART NO SYSTEM

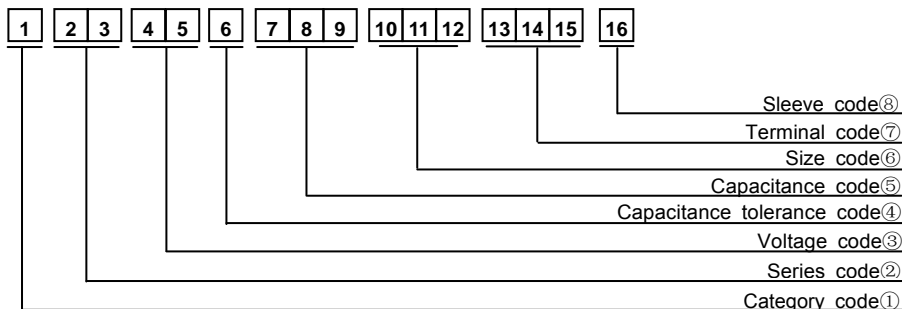

① Category code

Type	Code	
	1th	
Electrolytic Capacitor	E	

② Series code

Series name	Code	
	2 th	3 th
GH	G	H

③ Voltage code

WV(V)	Code	
	4th	5th
4	0	G
6.3	0	J
10	1	A
16	1	C
25	1	E
35	1	V
40	1	G
50	1	H
63	1	J
80	1	B
100	1	K
160	2	C
180	2	L
200	2	D
220	2	N
250	2	E
315	2	F
350	2	V
380	2	P
400	2	G
420	2	T
450	2	W
500	2	H

④ Capacitance Tolerance code

Tol. (%)	Code	
	6th	
-10~+10	K	
-20~+20	M	
-10~+30	Q	
-10~+50	T	
-10~+20	V	
-0~+20	A	
-5~+20	C	
-10~-20	B	
-5~+5	D	
-0~+10	E	
-5~-20	F	
-15~+5	N	

⑤ Capacitance code

Cap (μF)	Code		
	7th	8th	9th
0.10	R	1	0
0.22	R	2	2
0.33	R	3	3
0.47	R	4	7
0.68	R	6	8
1	0	1	0
2.2	2	R	2
3.3	3	R	3
4.7	4	R	7
6.8	6	R	8
10	1	0	0
22	2	2	0
33	3	3	0
47	4	7	0
68	6	8	0
100	1	0	1
220	2	2	1
330	3	3	1
470	4	7	1
680	6	8	1
1000	1	0	2
2200	2	2	2
3300	3	3	2
4700	4	7	2
6800	6	8	2
10000	1	0	3
22000	2	2	3
33000	3	3	3
68000	6	8	3

⑥ Size code

ΦD	Code	
	10th	
4	C	
5	D	
6.3	E	
8	F	
10	G	
11	H	
12	J	
12.5	W	
13	K	
14	X	
16	L	
18	M	
19	Z	
20	N	
22	O	
25	P	
30	Q	
35	R	
40	Y	
51	S	
63.5	T	
76	U	
89	V	

L	Code	
	11th	12th
5	0	5
7	0	7
11	1	1
12	1	2
16	1	6
20	2	0
25	2	5
30	3	0
35	3	5
40	4	0
46	4	6
50	5	0
60	6	0
80	8	0
100	A	0
115	B	5
120	C	0
130	D	0
140	E	0
160	G	0
200	K	0

⑦ Terminal Code

Specification	Code		
	13th	14th	15th
Bulk packing	O	-	-
编带 Taping F=5mm (4Φ~8Φ)	P	5	0
Taping F=2.5mm (4Φ~5Φ)	X	2	5
Taped Straight-pack	B	5	0
		3	5
		2	5
		2	0
		1	5
Lead Cut L=3.5mm	C	3	5
Lead Cut L=11.0mm	C	B	0
Lead Forming & cut L=4.5mm	F	4	5
Kink & cut L=4.5mm	J	4	5

⑧ Sleeve Code

Sleeve	Code	
	16th	
PVC	C	
PET	T	

Name	Approval Sheet-GH			
File No.	GH	Version	01	Page 13
STANDARD MANUAL				

Starts	File	Description	Component	No./rev
Released	Approval	Sheet-GH	CRS-2010-GH/ 01	

9. 加工型式 Forming Lead Type

9.1 编带 Taping

•Straight lead type

PIN Code : X

ΦD=4~5

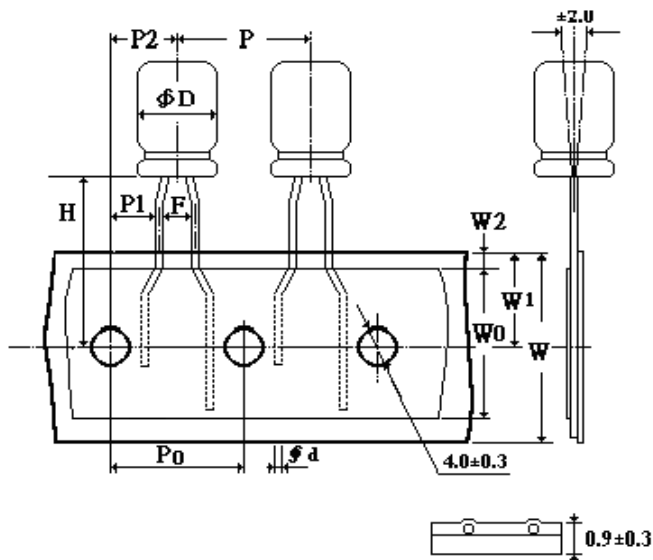

PIN Code : B

ΦD=4~8

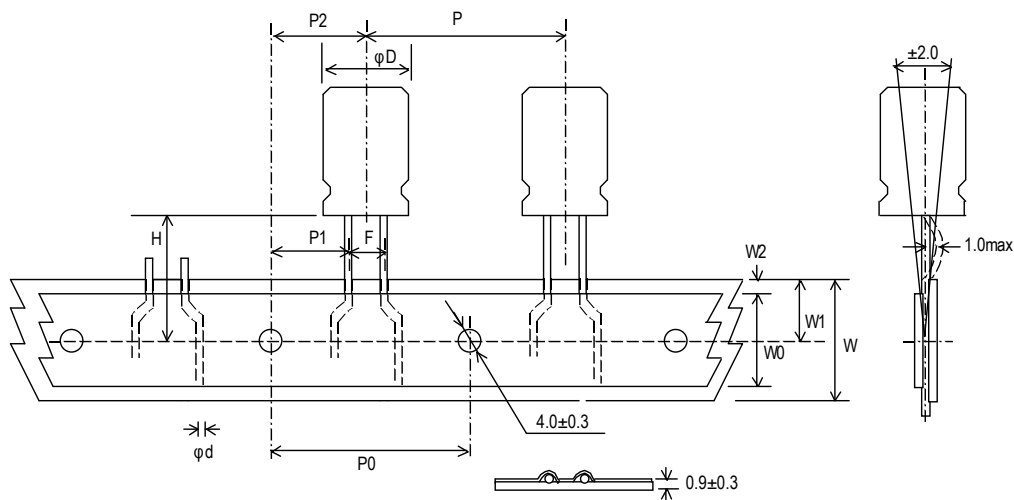

Name	Approval Sheet-GH			
File No.	GH	Version	01	Page 14
STANDARD MANUAL				

Starts	File Description	Component	No./rev
Released	Approval Sheet-GH	CRS-2010-GH/ 01	

PIN Code : B
ΦD=10

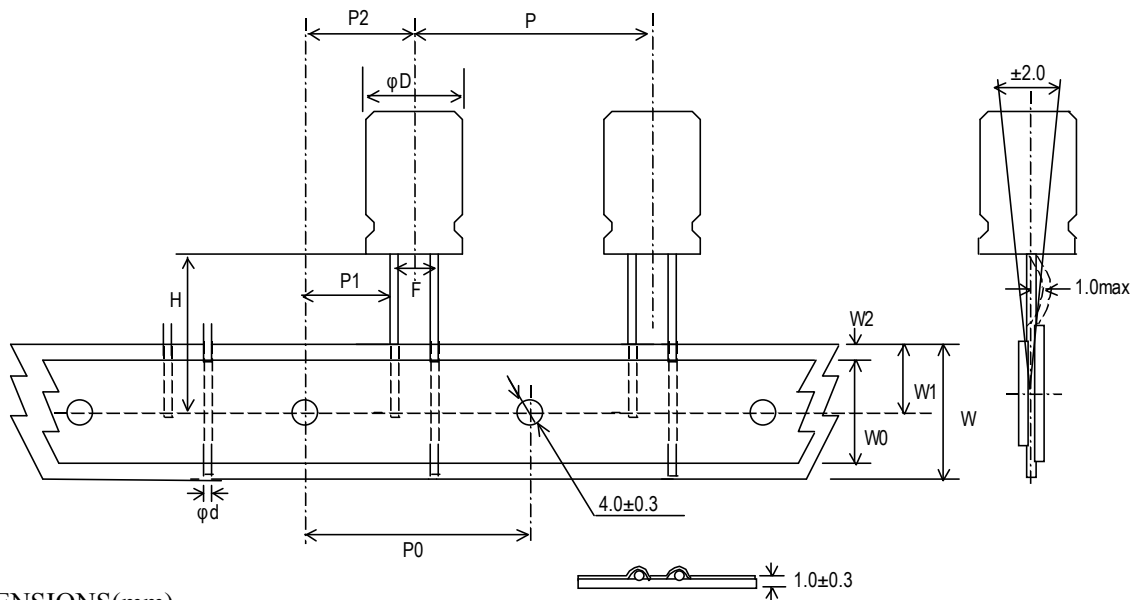

DIMENSIONS(mm)

Items	Symbol	CASE SIZE										Tolerance		
		4x5 4x7		5x5 5x7		5x11		6.3x5	6.3x7	6.3x11	8x5 8x7 8x11 8x12		8x16 8x20	10x13 10x16 10x20
Pin Code		X	B	X	B	X	B	B	B	B	B	B	B	
Lead wire diameter	Φd	0.45		0.45		0.5		0.45	0.5	0.5	0.45/0.5	0.5/0.6	0.6	±0.05
Pitch of body	P	12.7		12.7		12.7		12.7	12.7	12.7	12.7	12.7	12.7	±1.0
Feed hole pitch	P0	12.7		12.7		12.7		12.7	12.7	12.7	12.7	12.7	12.7	±0.2
Hole center to lead distance	P1	5.1	5.6	5.1	5.35	5.1	5.35	5.1	5.1	5.1	4.6	4.6	3.85	±0.7
Feed hole center to body center distance	P2	6.35		6.35		6.35		6.35	6.35	6.35	6.35	6.35	6.35	±1.0
Lead to lead distance	F	2.5	1.5	2.5	2.0	2.5	2.0	2.5	2.5	2.5	3.5	3.5	5.0	±0.5
Height of body from tape center	H	18.5		18.5		18.5		18.5	18.5	18.5	18.5	18.5	18.5	±0.75
Base tape width	W	18.0		18.0		18.0		18.0	18.0	18.0	18.0	18.0	18.0	±0.5
Adhesive tape width	W0	11.0		11.0		11.0		11.0	11.0	11.0	11.0	11.0	11.0	min
Hole position	W1	9.0		9.0		9.0		9.0	9.0	9.0	9.0	9.0	9.0	+0.75 -0.5
Hole down tape position	W2	3.0		3.0		3.0		3.0	3.0	3.0	3.0	3.0	3.0	max

Name	Approval Sheet-GH			
File No.	GH	Version	01	Page 15
STANDARD MANUAL				

Starts	File Description	Component	No./rev
Released	Approval Sheet-GH	CRS-2010-GH/ 01	

●Forming type

PIN Code : P

ΦD=4~8

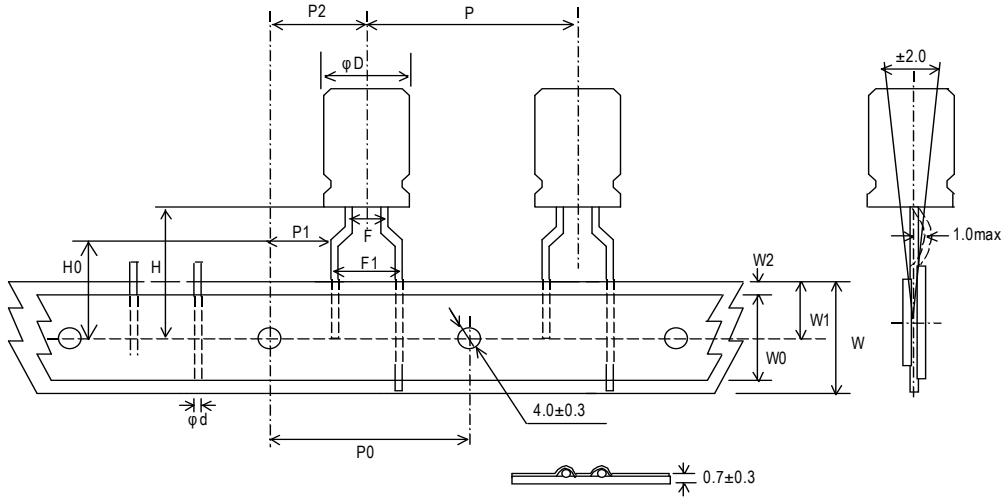

DIMENSIONS(mm)

Items	Symbol	CASE SIZE									Tolerance
		4x5 4x7	5x5	5x7	5x11	6.3x5	6.3x7	6.3x11	8x5 8x7 8x11 8x12	8x16 8x20	
Pin Code		P	P	P	P	P	P	P	P	P	
Lead wire diameter	Φd	0.45	0.45	0.45	0.5	0.45	0.5	0.5	0.45/0.5	0.5/0.6	±0.05
Pitch of body	P	12.7	12.7	12.7	12.7	12.7	12.7	12.7	12.7	12.7	±1.0
Feed hole pitch	P0	12.7	12.7	12.7	12.7	12.7	12.7	12.7	12.7	12.7	±0.2
Hole center to lead distance	P1	3.85	3.85	3.85	3.85	3.85	3.85	3.85	3.85	3.85	±0.7
Feed hole center to body center distance	P2	6.35	6.35	6.35	6.35	6.35	6.35	6.35	6.35	6.35	±1.0
Lead to lead distance	F	1.5	2.0	2.0	2.0	2.5	2.5	2.5	3.5	3.5	±0.5
Lead to lead distance	F1	5.0	5.0	5.0	5.0	5.0	5.0	5.0	5.0	5.0	+0.8 -0.2
Height of body from tape center	H	18.5	18.5	18.5	18.5	18.5	18.5	18.5	18.5	18.5	±0.75
Lead wire clinch height	H0	16.0	16.0	16.0	16.0	16.0	16.0	16.0	16.0	16.0	±0.5
Base tape width	W	18.0	18.0	18.0	18.0	18.0	18.0	18.0	18.0	18.0	±0.5
Adhesive tape width	W0	11.0	11.0	11.0	11.0	11.0	11.0	11.0	11.0	11.0	min
Hole position	W1	9.0	9.0	9.0	9.0	9.0	9.0	9.0	9.0	9.0	+0.75 -0.5
Hole down tape position	W2	3.0	3.0	3.0	3.0	3.0	3.0	3.0	3.0	3.0	max

Name	Approval Sheet-GH				
File No.	GH	Version	01	Page	16
STANDARD MANUAL					

Starts	File	Description	Component	No./rev
Released	Approval	Sheet-GH	CRS-2010-GH/ 01	

9.2 端子切脚或成型 Lead Cut& Lead Forming

● **LEAD CUT**
PIN CODE: C
RANGE: $\Phi 4\sim\Phi 18$

● **LEAD FORMING AND CUT**
PIN CODE: F
RANGE: $\Phi 4\sim\Phi 8$

ΦD	F	L	ΦD	F	L
4	1.5	3.0~12.0	4	5.0	3.5, 4.5, 5.0, 7.0
5	2.0	3.0~12.0	5	5.0	3.5, 4.5, 5.0, 7.0
6.3	2.5	3.0~12.0	6.3	5.0	3.5, 4.5, 5.0, 7.0
8	3.5	3.0~12.0	8	5.0	3.5, 4.5, 5.0, 7.0
10	5.0	3.0~12.0	-	-	-
12.5	5.0	3.0~12.0	-	-	-
16	7.5	3.0~12.0	-	-	-
18	7.5	3.0~12.0	-	-	-

● **Kink & cutting**
PIN CODE: J
RANGE: $\Phi 10\sim\Phi 18$

ΦD	F	L
10	5.0	4.0, 4.5, 5.0
12.5	5.0	4.0, 4.5, 5.0
16	7.5	4.0, 4.5, 5.0
18	7.5	4.0, 4.5, 5.0

Name	Approval Sheet-GH				
File No.	GH	Version	01	Page	17
STANDARD MANUAL					

Starts	File Description	Component	No./rev
Released	Approval Sheet-GH	CRS-2010-GH/ 01	

10. 包装 Packing

包装标签内容 Packing Label Marked (the following items shall be marked on the label)

(Inside box or bag)

1)系列 series 2)料号 P/N 3)容量 Rated capacitance 4)电压 Rated Voltage

5)数量 quantity 6)尺寸 size

批号的填写 LOT Number :

1	2	3	4	5	6	7	8
---	---	---	---	---	---	---	---

年份 月份 序号
year month number

编带产品按下图包装 Taped Packing.

单位 unit: mm

ΦD	L(max)	H(max)	W(max)
Φ4、Φ5、Φ6、Φ8	330	260	50
Φ10	330	260	62

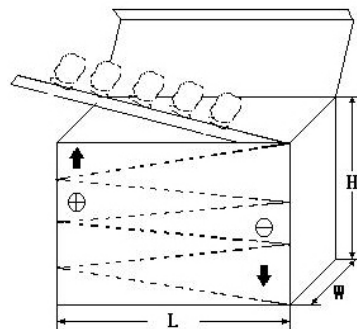

散包装按下图包装方式 Bulk Packing

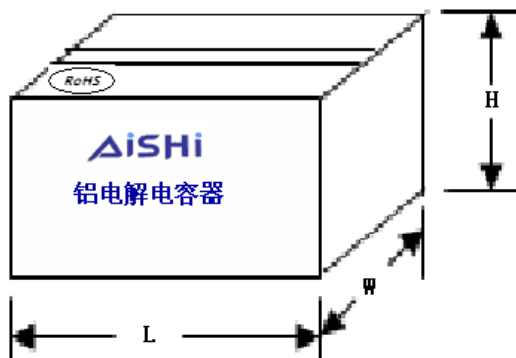

Name	Approval Sheet-GH			
File No.	GH	Version	01	Page 18
STANDARD MANUAL				

Starts	File	Description	Component	No./rev
Released	Approval	Sheet-GH	CRS-2010-GH/ 01	

11. 其它说明 OTHER REMARKS

11.1 铝电解电容器使用注意事项 IMPORTANT INFORMATION ON THE APPLICATION OF ALUMINUM ELECTROLYTIC CAPACITORS

(1)直流铝电解电容器应按正确的极性使用 DC aluminum electrolytic capacitors are normally polarized

当直流铝电解电容器按反极性接入电路时，电容器会导致电子线路短路，由此产生的电流会引致电容器损坏。若电路中有可能在负引线施加正电压，请选无极性产品。

When reverse voltage is applied on DC aluminum electrolytic capacitor ,the circuit will be short out and the capacitor will be damaged due to abnormal current flows through the capacitor.Please use non- polar types of capacitors when the positive voltage is applied on the cathode terminal.

(2)在额定工作电压以下使用 Use capacitor within rated voltage

当电容器上所施加电压高于额定工作电压时，电容器的漏电流将上升，其电气特性将在短时间内劣化直至损坏。请注意电压峰值勿超出额定工作电压。

When capacitor is used at higher voltage than the rated voltage, leakage current increased, characteristics drastically deteriorated and damaged in a short period may occur as a result. Please take extra caution that the peak voltage should not exceed the rated voltage.

(3)作快速充放电使用 Sudden charge and discharge

当常规电容器被用作快速充电用途,其使用寿命可能会因为容量下降,温度急剧上升等而缩减。

When aluminum electrolytic capacitors for general purpose-use are employed in rapid charge and discharge application, its life expectancy may be shortened resulted from capacitance decrease, heat rise, etc.

(4) 电容器储存 Storage of the capacitor

请保管在室温 0~40℃，湿度 70%以下的环境。

We recommend the following conditions for storage: Ambient temperature: 0~40℃ ,Ambient humidity: <70%RH;

a) 产品储存期限: ≤12 个月;

Storage life: ≤ 12 months;

b) 产品储存期限>12 个月时，需充电后再使用;

If storage life >12 months, the products need to be charged again before using;

c) 存放时间超过 3 年的电解电容器应报废处理;

If Storage time >three years, the products need to be discarded;

d) 库存有效期以产品套管上印刷的时间开始计算;

Expiry Date: calculating from the date marked on the sleeve;

e) 请尽量以包装状态保管;

Please keep capacitors in the original package;

f) 请避免在以下环境下保管:

Avoid storing the capacitors under such circumstances:

※ 溅水、高温高湿及结露的环境。

With water and oil or damp &dewing location.

※ 溅油、或者充满气体油成分的环境。

With gas and oil.

※ 充满酸性有毒气体（硫化氢，亚硫酸，亚硝酸，氯，溴，溴化甲烷等）的环境。

With toxic gases such as hydrogen sulfide, sulfurous acid, nitrous acid, chlorine, bromine and methane.

Name	Approval Sheet-GH			
File No.	GH	Version	01	Page 19
STANDARD MANUAL				

Starts	File	Description	Component	No./rev
Released	Approval	Sheet-GH	CRS-2010-GH/ 01	

※ 直射阳光、臭氧、紫外线及放射线照射的环境。

With direct sunlight, Ozone, ultraviolet rays or radiation.

(5) 施加纹波电流应小于额定值 Use capacitor within rated ripple current

施加纹波电流超过额定值后，会导致电容器体过热，容量下降，寿命缩短。电容器上标注了额定电压，请将和直流电压叠加的纹波电压的峰值控制在额定工作电压以下。

If excessive ripple current is applied on the capacitor, excessive heat will be generated inside, the capacitance will be reduced and capacitor's life shall be shortened. Rated voltage has been marked on the capacitor; therefore, the peak value of the ripple voltage should be less than the rated voltage.

(6)使用环境温度 Ambient temperature

铝电解电容器的使用寿命会受到环境温度的影响。据科学统计，使用环境温度下降 10℃其使用寿命增加 1 倍。

Life of aluminum electrolytic capacitor is affected by the ambient temperature. It is generally known that the life doubles for each 10℃ decrease in temperature.

(7)引出线强度 Tensile strength of lead wire

当拉力施加到电容器引出线，该拉力将作用于电容器内部，这可能导致电容器内部短路，开路或漏电流上升。在电容器焊装到电路板，请勿强烈摇动电容器。

When a strong force is applied to the lead wires or terminals, stress is put on the internal connections, which may result in short circuit, open circuit or increased leakage current. So it is not advisable to bend or handle a capacitor after it has been soldered to the PC board.

(8)焊接过程耐热性 Heat resistance at the soldering process

铝电解电容器装至电路板进行浸焊或波峰焊时，其塑料套管可能因焊接时间过长、温度过高而发生破裂或二次收缩。

During soldering process, secondary shrinkage or sleeve crack may occur when soldering temperature is too high or soldering time is too long.

(9)电路板的安装孔孔距及安装位置 Hole pitch and position of PC board

电路板安装孔的设计应与产品说明书的引线脚距相一致，如果将电容器强行插入孔距不配套的电路板，那么会有应力作用于引出线，这可能导致短路或漏电流上升。

When designing a PC board, its hole pitch should be designed to coincide with the lead pitch(lead spacing) of the capacitor specified in the catalog or specifications. When a capacitor is forcibly inserted into an unmatched hole pitch, a force will put on the leads and which could result in a short circuit or increased leakage current.

(10) 关于焊接以后的清洗 Cleaning after soldering

① 电容器不能用卤化有机物系列的清洗剂进行清洗。如果必须进行清洗，请使用能够保证电容器质量的清洗剂。

The aluminum electrolyte capacitors should be free halogenated solvents during board cleaning after soldering. Use solvent proof capacitors when halogenated solvents are used.

② 对于能够保证电容器质量的清洗剂，清洗后请不要在清洗溶液或者密封容器中保管。清洗后的电容器请和电路板一起在热风下干燥 10 分钟以上，热风的温度不可高于电容器规定上限温度。

After cleaned with the solvent which should proof the quality of capacitors, the capacitors should not be kept in solvent environments of non-ventilated places. Let the capacitors after cleaning dry with hot blast fully above 10mins and the temperature of hot blast should not be over than specified upper limit of capacitors.

(11) 关于固定剂以及镀层（涂层剂）Adhesives、fixative and coating materials(coating agent)

① 请不要使用含有卤化有机物系列的固定剂及镀层（涂层剂）。

Do not use halogenated adhesives and coating materials to fix aluminum electrolytic capacitors.

Name	Approval Sheet-GH			
File No.	GH	Version	01	Page 20
STANDARD MANUAL				

<i>Starts</i>	<i>File</i>	<i>Description</i>	<i>Component</i>	<i>No./rev</i>
Released	Approval	Sheet-GH	CRS-2010-GH/ 01	

② 请不要让固定剂及镀层（涂层剂）将电容器封口部位（端子一侧）全部封住。

Do not cover up all the sealing area of capacitors with adhesives、fixative or coating materials(coating agent), make coverage only partial.

11.2 符合 RoHS RoHS compliance

符合欧盟 RoHS 的最新标准，若客户有特殊要求，按照双方签订的相关协议为准。

Accord with the latest standard of RoHS,if customers have any special requirements,according to the relevant agreements which signed by both parts.

Name	Approval Sheet-GH				
File No.	GH	Version	01	Page	21
STANDARD MANUAL					