

UNIVERSAL HIGH BRIGHTNESS LED DRIVER

FEATURES

- Efficiency >90%
- Input voltage range 10V to 600V
- Withstanding input voltage surge up to 600V
- Output current range a few mA to more than 1A
- String of LEDs 1 pc to several hundreds
- Constant-current LED driver
- Linear and PWM dimming capability

APPLICATIONS

- DC/DC or AC/DC LED driver
- RGB backlighting LED driver
- Backlighting of flat panel displays
- General-purpose constant current source
- Signage and decorative LED lighting
- Automotive
- Chargers

PIN CONFIGURATION

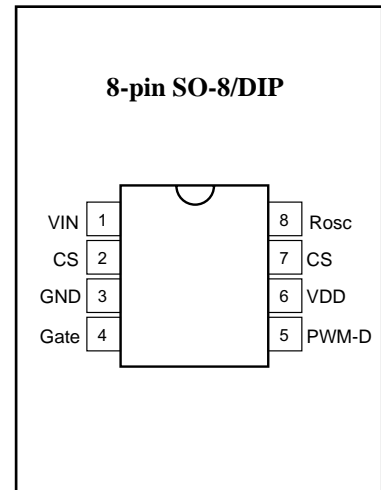

DESCRIPTION

The HG9910 is a PWM high-efficiency LED driver control IC. It allows efficient operation of high-brightness (HB) LEDs from 10VDC up to 600VDC voltage sources. The circuit controls an external MOSFET at fixed switching frequencies up to 300 kHz. The frequency can be programmed by using a single resistor. The device peculiarity is that a LED string is driven at a constant current rather than at a constant voltage, thus providing a constant light output and an enhanced reliability. The output current can be programmed between a few milliamps and up to more than 1.0A. A rugged high-voltage junction isolated process was used and enabled the device to withstand an input voltage surge up to 600V. The output current to a LED string is programmable to any value between zero and its maximum value by applying an external control voltage to the linear dimming control input. To allow the device to accept an external control signal with a duty ratio of 0 to 100% and a frequency of up to a few kilohertz the circuit has a low-frequency PWM dimming input.

TYPICAL APPLICATION CIRCUIT

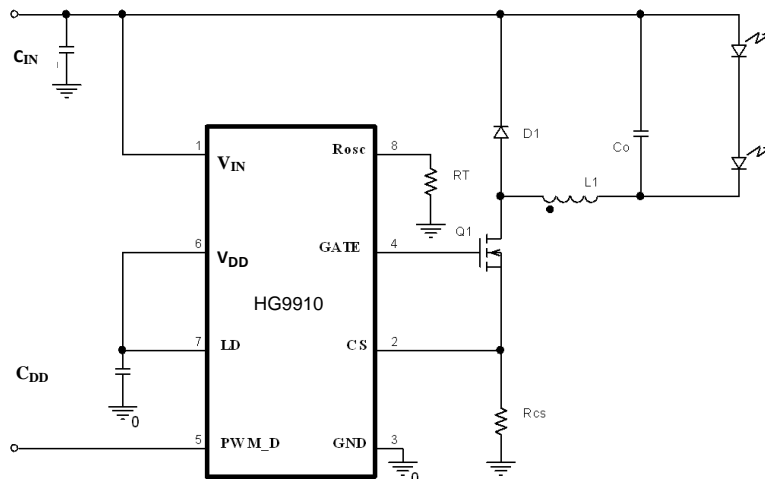

ABSOLUTE MAXIMUM RATINGS

V_{IN} to GND	-0.5V to +600V
CS, LD, PWM_D, GATE to GND	-0.3V to $V_{DD}+0.3V$
Continuous power dissipation ($T_A = +25^\circ C$) (Note 1)	
8-pin DIP (derate 9 mW/ $^\circ C$ above $+25^\circ C$)	900mW
8-pin SO-8 (derate 6.3 mW/ $^\circ C$ above $+25^\circ C$)	630mW
Operating temperature range	-40 $^\circ C$ to +85 $^\circ C$
Junction temperature	+125 $^\circ C$
Storage temperature range	-65 $^\circ C$ to +150 $^\circ C$

Stresses beyond those listed under **ABSOLUTE MAXIMUM RATINGS** may cause permanent damage to the device. These are stress ratings only, and functional operation of the device at these or any other conditions beyond those indicated in the operational sections of the specifications are not implied. Exposure to absolute maximum rating conditions for extended periods may affect device reliability.

ELECTRICAL CHARACTERISTICS

($T_A = +25^\circ C$ unless noted otherwise)

SYMBOL	DESCRIPTION	MIN	TYP	MAX	UNITS	CONDITIONS
V_{INDC}^1	Input DC supply voltage range	10.0		600	V	DC input voltage
I_{INSD}	Shut-down mode supply current	0.5		1	mA	Pin PWM_D to GND, $V_{IN} = 8V$
V_{DD}	Internally regulated voltage	7.0	7.5	8.0	V	$V_{IN} = 10V$ to 600V, $I_{DD(ext)} = 0$, pin GATE is open
$\Delta V_{DD, load}$	V_{DD} load regulation	0	-	100	mV	$I_{DD(ext)} = 0$ to 1.0mA, 500pF at GATE; $R_{OSC} = 226k\Omega$, PWM_D = V_{DD}
$V_{DD,max}$	Maximal pin V_{DD} voltage			10.0	V	When an external voltage is applied to pin V_{DD}
$I_{DD(ext)}$	V_{DD} current available for external circuitry			0.7	mA	$V_{IN} = 10V$ to 100V
UVLO	V_{DD} undervoltage lockout threshold	$0.87 * V_{DD}$	$0.89 * V_{DD}$	$0.91 * V_{DD}$	%	Rising V_{IN}
$\Delta UVLO$	V_{DD} undervoltage lockout hysteresis		500		mV	Falling V_{IN}
$V_{EN(lo)}$	Pin PWM_D input low voltage			0.8	V	$V_{IN} = 10V$ to 600V
$V_{EN(hi)}$	Pin PWM_D input high voltage	2.0			V	$V_{IN} = 10V$ to 600V
R_{EN}	Pin PWM_D pull-down resistance	50	100	150	k Ω	$V_{EN} = 5V$
dV _{CS}	Accuracy of Current Sense threshold voltage at wafer testing	-2.4%	0	2.4%	%	
$V_{CS(hi)}$	Current sense pull-in threshold voltage	238	250	262	mV	$T_A = -40^\circ C$ to +85 $^\circ C$
$V_{GATE(hi)}$	GATE high output voltage	$V_{DD}-0.3$		V_{DD}	V	$I_{OUT} = 10mA$
$V_{GATE(lo)}$	GATE low output voltage	0		0.3	V	$I_{OUT} = -10mA$
f_{OSC}	Oscillator frequency	20 80	25 100	30 120	kHz	$R_{OSC} = 1.00M\Omega$ $R_{OSC} = 226k\Omega$
$D_{MAX hf}$	Maximum oscillator PWM duty cycle			100%		$F_{PWM hf} = 25kHz$, at GATE, CS to GND
V_{LD}	Pin LD (linear dimming) voltage range	0		250	mV	$T_A = <85^\circ C$, $V_{IN} = 12V$
T_{BLANK}	Current sense blanking interval	150	215	280	ns	$V_{CS} = 0.55V_{LD}$, $V_{LD} = V_{DD}$
t_{DELAY}	Delay from CS to GATE lo			300	ns	$V_{IN} = 12V$, $V_{LD} = 0.15$, $V_{CS} = 0$ to 0.22V after T_{BLANK}
t_{RISE}	GATE output rise time	30		50	ns	$C_{GATE} = 500pF$, $V_{DD} = 7.5V$
t_{FALL}	GATE output fall time	30		50	ns	$C_{GATE} = 500pF$, $V_{DD} = 7.5V$

Note:

- Also limited by package power dissipation limit, whichever is lower.

BLOCK DIAGRAM

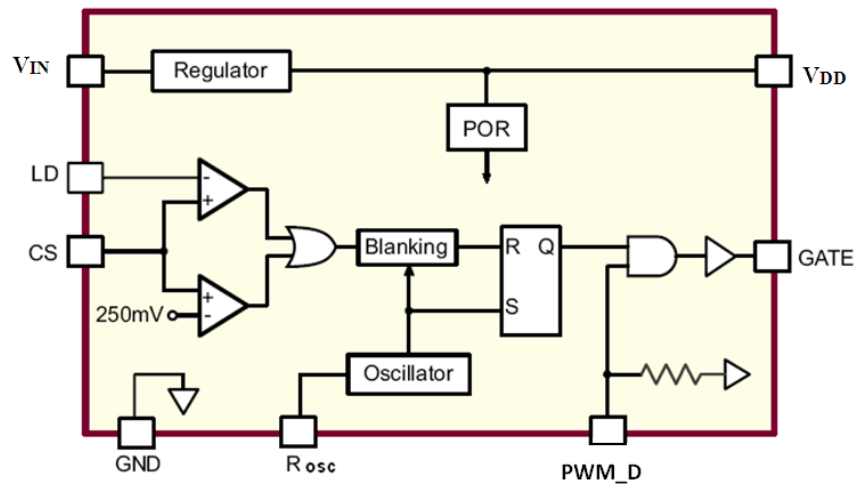

Application Note

Oscillator

The oscillator in the HG9910 is controlled by a single resistor connected at the RT pin. The equation governing the oscillator time period t_{OSC} is given by:

If the resistor is connected between RT and GND, HG9910 operates in a constant frequency mode and the above equation determines the time-period. If the resistor is connected between RT and GATE, the HG9910 operates in a constant off-time mode and the above equation determines the offtime.