

规格书
Specification

品名
Model name

HNB09A12
ROHS

PROPRIETARY
Huaneng Electronic co.,Ltd.

CONFIDENTIAL
Huaneng Electronic co.,Ltd.

Version #	Spec V1.0
制作日期 Date	2018/03/08
准备 Prepared	Yang shu yin Acoustic specialist,R&D Dept.
审核 Approved	Zhang chang hua Executive Manager,R&D Dept.



江苏华能电子有限公司

*Components Operating Div.
HuanengElectronic co.,Ltd.*

1.适用范围：本规范适用于HNB09A12 ROHS蜂鸣器。

This specifications apply the HNB09A12 ROHS buzzer.

2.基本规格/General specification

项目/Item	规格/Spec	条件/Condition
1 额定电压 Rated voltage	12VDC	
2 工作电压 Operation voltage	8~16VDC	
3 声压 Sound Pressure Level=SPL	Min 85dB	测试环境：标准状态，标准驱动电路， 额定电压 测试距离：0.1m Standard State,Standard Drive Circuit. Rated voltage,Distance at 0.1m
4 平均消费电流 Average consumption current	Max 30mA	
5 振荡频率 Oscillation frequency	3000±300Hz	
6 响应时间 Response time	Max 50mS	最低工作电压 Lowest operation voltage
7 工作温度范围 Range of operation temperature	-20~+70°C	声压 ≥80dB SPL ≥80dB
8 保存温度范围 Range of preservation temperature	-30~+85°C	
9 端子强度 Terminal strength	10N	拉负荷方向的终端轴 Pull load on the direction of the terminal axis
10 外部尺寸 Externals size	Φ9×5.5	参阅附图 Refer to the attached drawing
11 重量 Mass	0.7g	

☆标准状态：常温（15~35°C），湿度（25~85%相对湿度），空气压力（860~1060hpa）
在假设的情况判断，测试是一基本状态下进行。

Standard State:Ordinary Temp(15~35°C),Humidity(25~85%RH),Air pressure(860~1060hPa)
In case of doubtful judgment,the test is re—performed under Basic State.

☆基本情况：温度。（20±2°C），湿度（60~70%相对湿度），空气压力（860~1060hpa）
Basic State: Temp.(20±2°C),Humidity(60~70%RH),Air pressure(860~1060hPa)

<标准驱动电路>/<Standard Drive Circuit>

<标准测试治具>/<Standard Test Fixture>

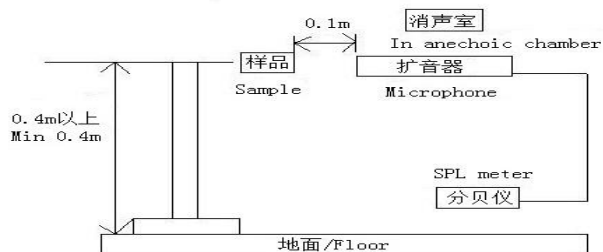
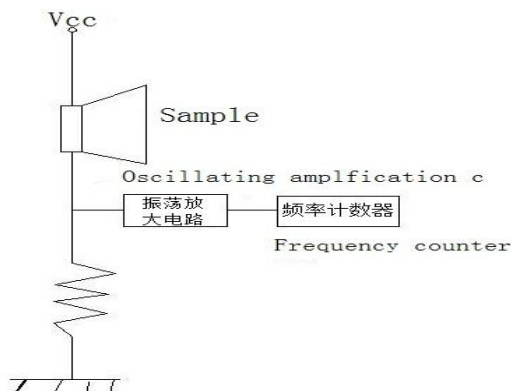

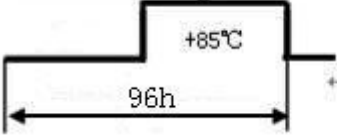
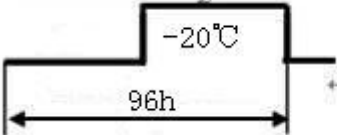
项目/Item	试验条件/Test condition	判断标准/Criteria	引用规格
1 高温保存试验 High temperature Preservation	+85℃环境下放置24小时 Exposure to +85℃ for 24 hrs.	经过测试, 符合规格, 没有任何不合格的外观和性能 After the test the part shall meet specificati- -ons without any degra.	
2 低温保存试验 Low temperature preservation	-20℃环境下放置24小时 Exposure to -20℃ for 24 hrs.		
3 高温试验 High temperature Shock			
4 低温试验 Low temperature Shock			
5 常温寿命试验 Ordinary Temp. Life	常温 (25℃±10℃) 电压12VDC连续测试48小时 Driving the sounder at 12VDC for 48hrs in the room temperature (25℃±10℃)		
6 高温寿命试验 High Temp. Life	高温 (+85℃) 电压12VDC连续测试2小时 Driving the sounder at 12VDC for 2hrs in the low temperature (+85℃)		
7 低温寿命试验 Low Temp. Life	低温 (-20℃) 电压12VDC连续测试2小时 Driving the sounder at 12VDC for 2hrs in the low temperature (-20℃)		
8 端子拉力试验 Lead strength	10N的拉力在端子上拉10±1秒 Pull load on the direction of the terminal axis for 10±1 sec.		
9 跌落试验 Free drop	70cm高自由掉落到厚40mm的木板上, 每个方向一次 Free drop, 70cm height, on wood board (t40mm) X, Y, Z 3Direction 1time each, total 3times.		
10 端子可焊性试验 Solderability	260±5℃焊接温度。时间: 5±0.5sec。 Temp. 260±5℃ Soaking Time: 5±0.5sec	端子95%必须覆盖着焊料 95% surface of lead pins must be covered with fresh solder and no soldering holes Should be found	

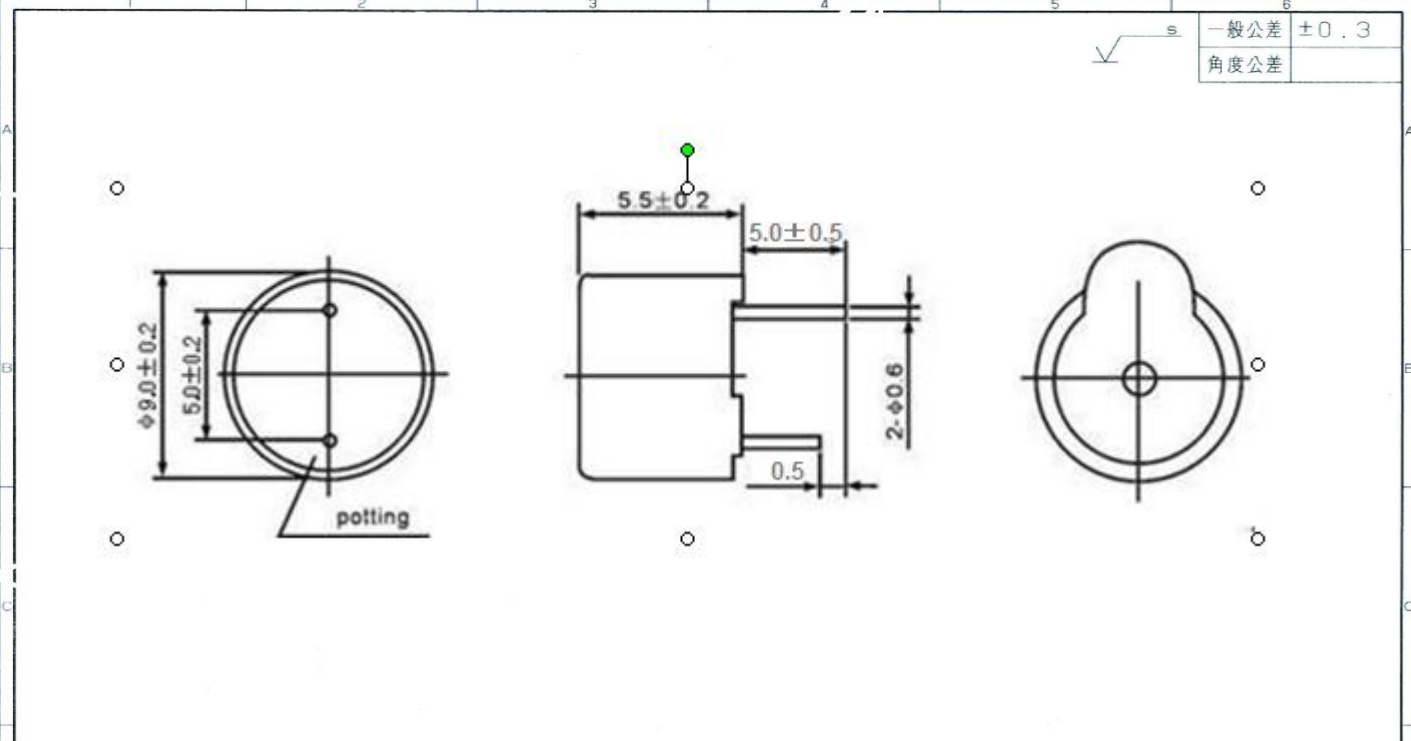

		审批 APPROVED	张长华	材料 MATERIAL	PPO料	制造日期 DATE	出图日期
		检查 CHECKED	杨树银	加工 TREATMENT		品名 NAME	APPEARANCE DRWG
		设计 DESIGNED		表面处理 SURF. FIN.			产品名称
		制图 DRAWN		第三角法	尺度 SCALE	品号 CODE NO.	
日期 DATE	变更号码 CHANGE NO.	变更内容 CHANGE CONTENTS		江苏华能电子有限公司 HUANENG Electronic Co.,Ltd			

产品特征图

