

THIS DRAWING IS UNPUBLISHED.  
 DIFFUSION RESTREINTE AMP  
 © COPYRIGHT - By -  
 ALL RIGHTS RESERVED.  
 TOUS DROITS RESERVES

LOC	DIST	REVISIONS			
P	LTR REV	DESCRIPTION MODIFICATIONS	DATE	DWN DESS.	APVD APP.
F	7	G2	TIN PLATING THICKNESS CORRECTED AND REELING DIRECTION IS ALSO ADDED	29JUN2015	NG PS

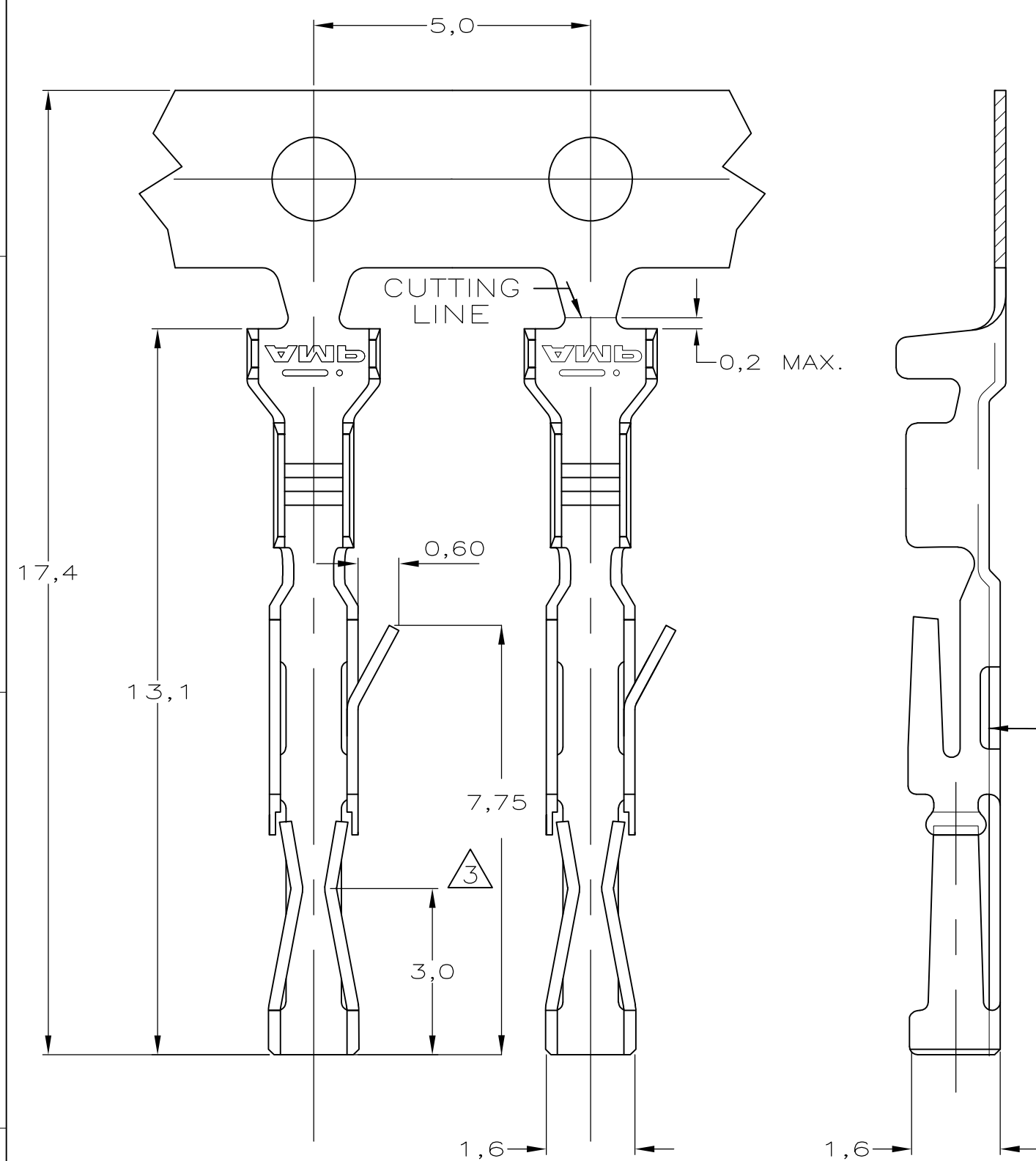

NOTES:

- ① CONTACT MATERIAL: PHOSPHORBRONZE
- ② PLATING: MIN. 1,5µm Sn
- ③ CONTACT POINT
- ④ BOTTOM OF CONTACT TO BE STRAIGHT AFTER CRIMPING OF WIRE
- 5 WIRE RANGE: 0,08-0,22mm<sup>2</sup>  
INSULATION RANGE: 0,80-1,50 DIA.
- ⑥ OPTIONAL
- 7 THE CONTACT MEETS THE REQUIREMENT OF INTERNATIONAL STANDARD IEC 603-8
- ⑧ LOOSE PIECE VERSION

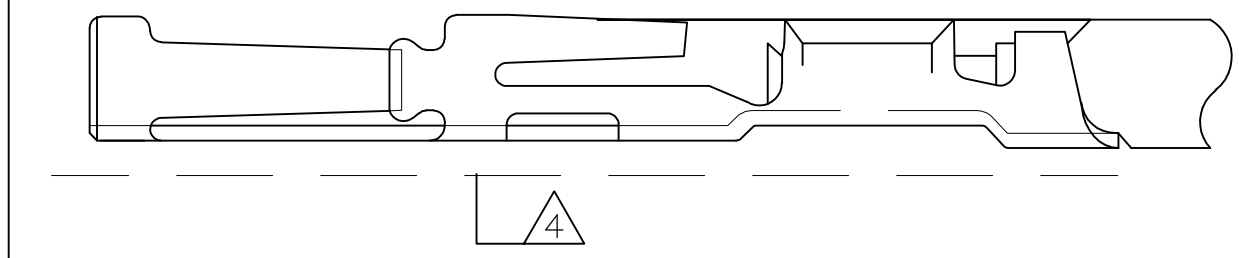
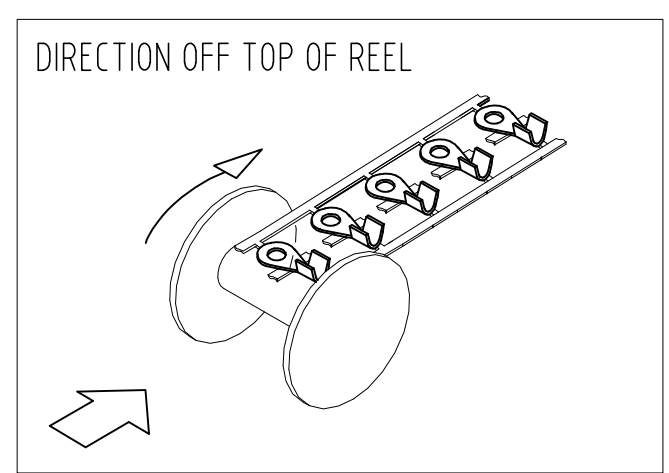

	188744-1	182734-2	⑧
②	①	188744-1	
FINISH	MATERIAL	PART NUMBER	

THIS DRAWING IS A CONTROLLED DOCUMENT. CE PLAN EST UN DOCUMENT CONTROLE		DWN / DESSINE 22-NOV-04 Jean-Jacques DESPRETZ		 TE Connectivity	
DIMENSIONS: mm		CHK / VERIFIE T CORRIOU			
TOLERANCES UNLESS OTHERWISE SPECIFIED: TOLERANCES NON SPECIFIEES (SUIV NB DE DECIMALES):		APVD / APPROUVE Y PETRONIN		NAME TITRE	
0 - PLC / DEC ± -		PRODUCT SPEC SPEC. PRODUIT		HE1402 CONNECTOR (TIN VERSION)	
1 - PLC / DEC ± -		APPLICATION SPEC SPEC. APPLICATION		CRIMP CONTACT ( AWG 28-24 )	
2 - PLC / DEC ± -		WEIGHT MASSE APPROX. -		SIZE FORMAT A3	CAGE CODE 00779
3 - PLC / DEC ± -		FINISH FINITION -		DRAWING NO No PLAN G-188744	
4 - PLC / DEC ± -		MATERIAL MATIERE -		RESTRICTED TO -	
ANGLES ± -		CUSTOMER DRAWING/PLAN CLIENT		UNIQUEMENT POUR REFERENCE	SCALE ECHELLE 1:1
				SHEET FEUILLE 1 OF DE 1	REV G2