

规格书 Specification

品名
Model name

QMB-09A-03

PROPRIETARY
Huaneng Electronic co.,Ltd.

CONFIDENTIAL
Huaneng Electronic co.,Ltd.

Version #	Spec V1.0
制作日期 Date	2017/08/16
准备 Prepared	Yang shu yin Acoustic specialist,R&D Dept.
审核 Approved	Zhang chang hua Executive Manager,R&D Dept.



江苏华能电子有限公司

*Components Operating Div.
HuanengElectronic co.,Ltd.*

1.适用范围：本规范适用于QMB-09A-03蜂鸣器。

This specifications apply the QMB-09A-03 buzzer.

2.基本规格/General specification

项目/Item		规格/Spec	条件/Condition
1	额定电压 Rated voltage	3V	
2	工作电压 Operation voltage	2~5V	
3	声压 Sound Pressure Level=SPL	Min 80dB	测试环境：标准状态，标准驱动电路， 额定电压 测试距离：0.1m Standard State,Standard Drive Circuit. Rated voltage,Distance at 0.1m
4	平均消费电流 Average consumption current	Max 40	
5	振荡频率 Oscillation frequency	2700Hz	
6	响应时间 Response time	Max 50mS	最低工作电压 Lowest operation voltage
7	工作温度范围 Range of operation temperature	-20~+75°C	声压 ≥80dB SPL ≥80dB
8	保存温度范围 Range of preservation temperature	-30~+85°C	
9	线圈电阻 Coilresistance	16 ± 4 Ω	
10	外部尺寸 Externals size	Φ9x4.2	参阅附图 Refer to the attached drawing
11	重量 Mass	0.8g	

☆标准状态：常温（15~35°C），湿度（25~85%相对湿度），空气压力（860~1060hpa）
在假设的情况判断，测试是一基本状态下进行。

Standard State:Ordinary Temp(15~35°C),Humidity(25~85%RH),Air pressure(860~1060hPa)

In case of doubtful judgment,the test is re—performed under Basic State.

☆基本情况：温度。（20±2°C），湿度（60~70%相对湿度），空气压力（860~1060hpa）

Basic State: Temp.(20±2°C),Humidity(60~70%RH),Air pressure(860~1060hPa)

<标准驱动电路>/<Standard Drive Circuit>

<标标测试治具>/<Standard Test Fixture>

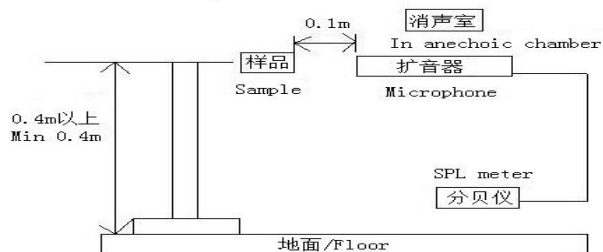
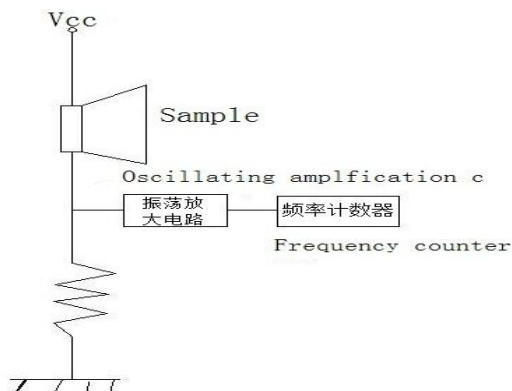

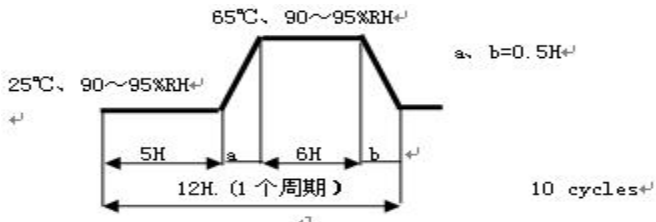
项目/Item	试验条件/Test condition	判断标准/Criteria	引用规格
1 高温保存试验 High temperature Preservation	+85℃环境下放置48小时 Exposure to +85℃ for 48 hrs.	经过测试,符合规格,没有任何不合格的外观和性能 After the test the part shall meet specificati- ons without any degra- de.	
2 低温保存试验 Low temperature preservation	-40℃环境下放置48小时 Exposure to -40℃ for 48 hrs.		
3 耐温试验 Thermal Shock	 <p>10次周期↕ 10 cycles↕</p>		
4 温湿度试验 Thermal, Humidity Shock	 <p>a, b=0.5H↕ 10 cycles↕</p>		
5 常温寿命试验 Ordinary Temp. Life	常温(25℃±10℃)电压3V连续测试48小时 Driving the sounder at 3V for 48hrs in the room temperature(25℃±10℃)		
6 高温寿命试验 High Temp. Life	高温(+85℃)电压3V连续测试2小时 Driving the sounder at 3V for 2hrs in the low temperature(+85℃)		
7 低温寿命试验 Low Temp. Life	低温(-40℃)电压3V连续测试2小时 Driving the sounder at 3V for 2hrs in the low temperature(-40℃)		
8 端子拉力试验 Lead strength	10N的拉力在端子上拉10±1秒 Pull load on the direction of the terminal axis for 10±1 sec.		
9 振动试验 Vibration	10~55~10Hz正弦波测试1分钟, 振幅 1.52mm 最大91m/S ² X, Y, Z三个方向每个2小时总计6小时 10~55~10Hz Sinewave, Sweep 1 min, Amplitude 1.52mm Max91m/S ² X, Y, Z 3Direction 2hrs each, Total 6hrs		
10 自由掉落试验 Free drop	70cm高自由掉落到厚40mm的木板上, 每个方向一次 Free drop, 70cm height, on wood board (t40mm) X, Y, Z 3Direction 1time each, total 3times.	排除弯曲的针 Exclude bending of Pin	
1 波峰焊耐热试验 Wave solderheat resistance test	262±10℃焊接温度。时间5±0.5sec Soldering into solderbath:Solder Temp. 262±10℃ Soaking Time: 5±0.5sec	经过测试,符合规格,没有任何不合格的外观和性能 After the test the part Shall meet specificatio- ns without any degrada- tion in appearance and performance	
1 耐洗性试验 Washability	溶剂:去离子水, 溶剂温度: 55±5℃, 时间: 5±0.5分钟 Solvent:deionized water, Solvent temp:55±5℃ Soaking time:5±0.5minutes		
1 3 端子可焊性试验 Solderability	40℃, 相对湿度90~95%RH放置48小时, 370±5℃焊接温度。 时间: 6±0.5sec。 Pretreatment:40℃, 90~95%RH*48hrs Soldering into solderbath:Solder Temp. 370±5℃ Soaking Time: 6±0.5sec	端子95%必须覆盖着焊料 95% surface of lead pins must be covered with fresh solder and no soldering holes Should be found	

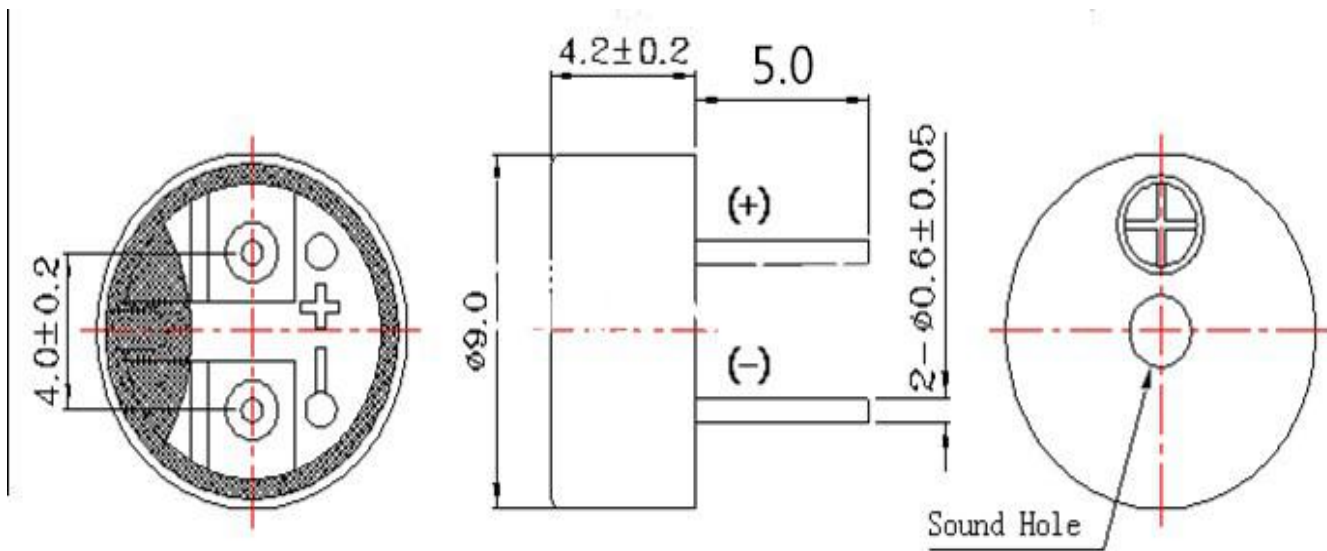

江苏华能电子有限公司
HUANENG Electronic Co.,Ltd

产品频率曲线图

