



规格书
Specification

江苏华能电子有限公司

JIANGSU HUANENG ELECTRONICS CO., LTD.

CUSTOMER:

MODEL NO.: MLT-1230

OUR PART NO.:

CUSTOMER PART NO.:

CUSTOMER	APPROVED	CHECKED

Add: Chenbao Industrial Park, Chenbao Town, Xinghua, Taizhou City, Jiangsu China.

江苏省兴化市陈堡镇工业园区

Tel:+86-523-83710666

Fax:+86-523-83724866

Email: hn@huawha.com; <http://www.huawha.com>



Specification for Electro-Magnetic Buzzer (SMD Type)				Page 2 of 6	
Model No.:		Part No.		Des.	Chk.
MLT-1230				4/10/2020	4/10/2020

1. Technical Parameter

Measuring condition

Part shall be measured under a condition (Temperature: 5 ~ 35°C, Humidity: 45% ~ 85%R.H., Atmospheric pressure: 860 ~ 1060hPa) unless the standard condition (Temperature: 25±3°C, Humidity: 60±10%R.H. Atmospheric pressure: 860 ~ 1060hPa) is regulated to measure.

2	Operating Voltage	3Vo-p
3	Rated Current	Max.5mA ,
4	Sound Output at 10cm	Min.75dB,
5	Capacitance	16000±30% pF
6	Resonant Frequency	4000±500Hz
7	Operating Temperature	-20°C ~ +70°C
8	Store Temperature	-30°C ~ +80°C
9	Net Weight	Approx 0.5g
10	RoHS	Yes

2. Dimensions

Unit: mm

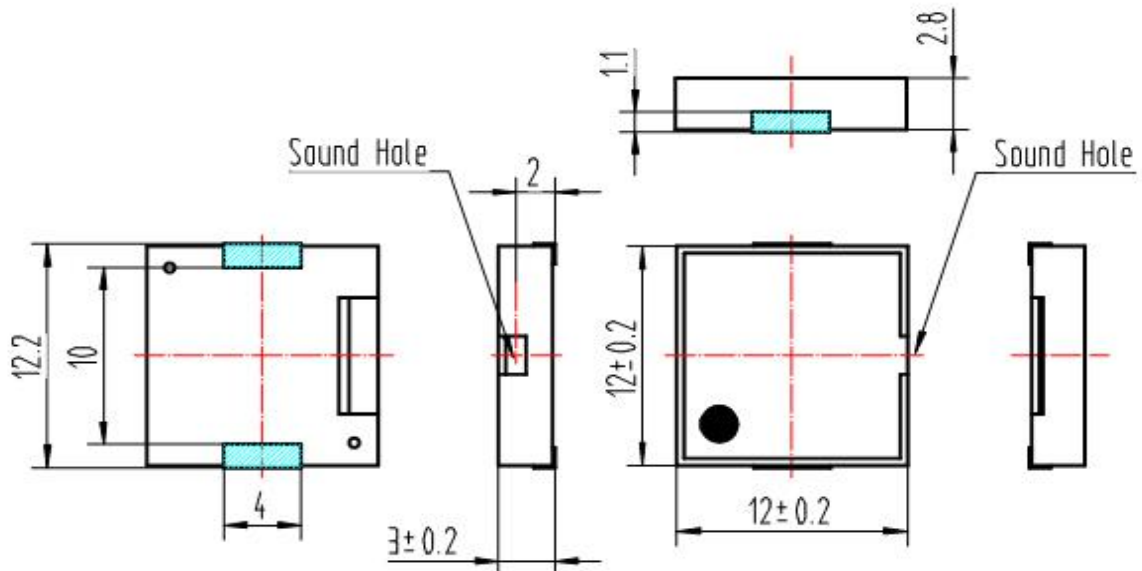

*Unit: mm; Tolerance: ± 0.3mm Except Specified

*Housing Material: Black LCP

*Terminal plate: 2 soldering pads, tin Plating Brass



Specification for Electro-Magnetic Buzzer (SMD Type)				Page 3 of 6	
Model No.:		Part No.		Des.	Chk.
MLT-1230				4/10/2020	4/10/2020

3. Electrical And Acoustical Measuring Condition

Recommended setting

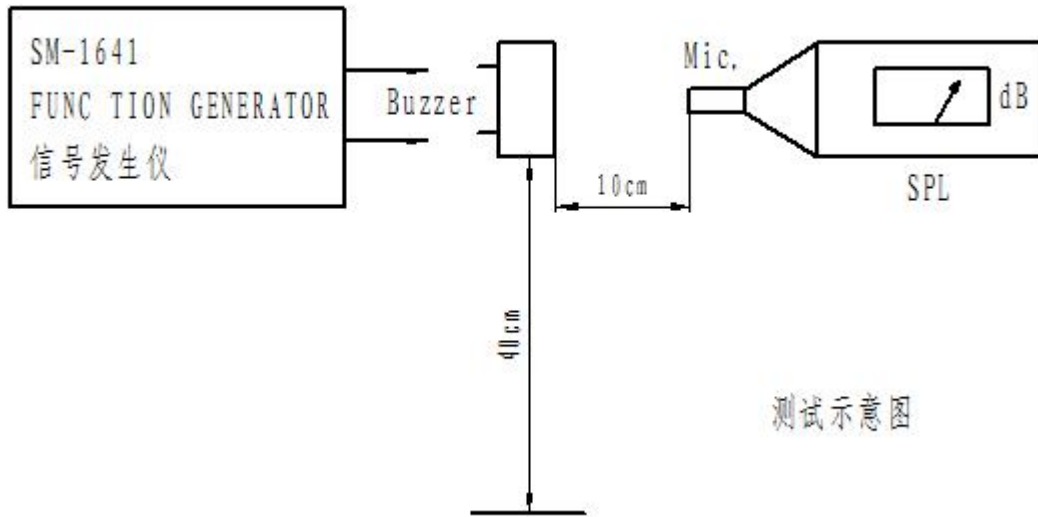

4. Frequency Response

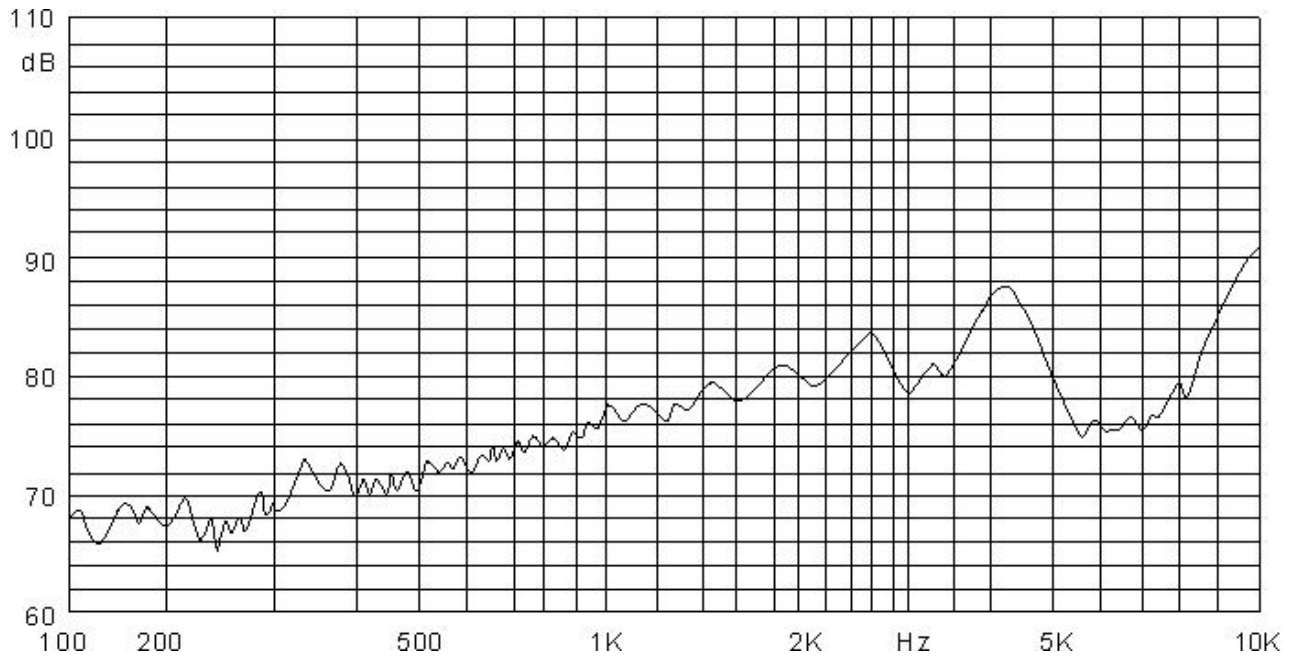



Specification for Electro-Magnetic Buzzer (SMD Type)				Page 4 of 6	
Model No.:		Part No.		Des.	Chk.
MLT-1230				4/10/2020	4/10/2020

5. Surface mounting condition

5.1 Reflow soldering

Recommendable reflow soldering condition is as follows.

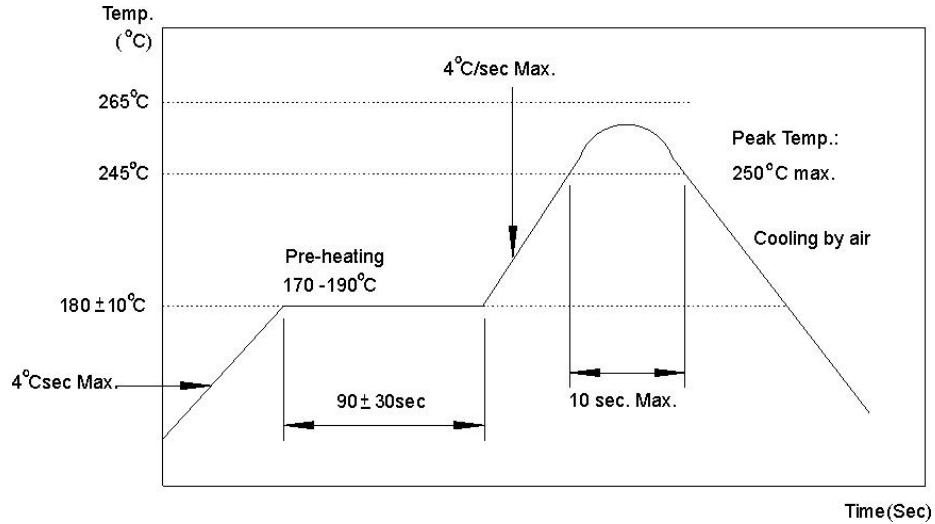

- Note:** (1) In automated mounting of the SMD sound transducers on PCB, any bending, expanding and pulling forces or shocks against the SMD sound transducers shall be kept minimum to prevent them from electrical failures and mechanical damages of the devices.
- (2) In the reflow soldering, too high soldering temperatures and too large temperature Gradient such as rapid heating or cooling may cause electrical failures and mechanical damages of the devices.

5.2 Soldering pattern

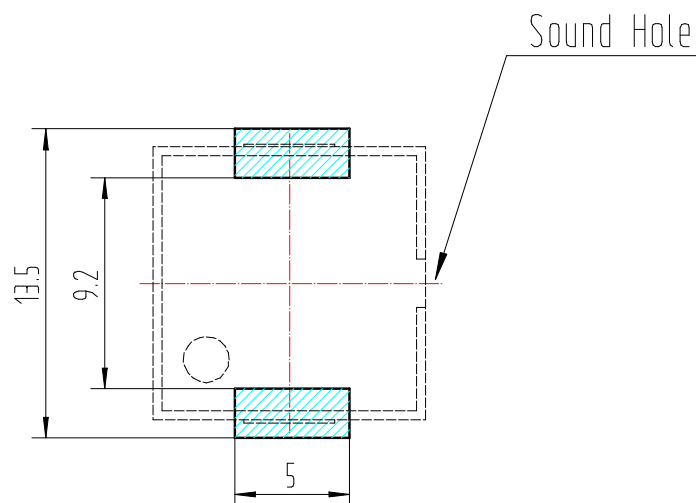



Specification for Electro-Magnetic Buzzer (SMD Type)				Page 5 of 6	
				Des.	Chk.
Model No.:	MLT-1230	Part No.			
				4/10/2020	4/10/2020

6. Reliability Test

After any following tests the part shall meet specifications without any degradation in appearance and performance except SPL. SPL shall not deviate more than -10 dB from the initial value

6.1 Ordinary Temperature Life Test

The part shall be subjected to 96 hours at 25±10°C. Input rated voltage Resonant frequency, 1/2 duty Square wave.

6.2 High Temperature Test

The part shall be capable of with standing a storage temperature of +80°C for 96 hours.

6.3 Low Temperature Test

The part shall be capable of with standing a storage temperature of -30°C for 96 hours.

6.4 Humidity Test

Temperature: +40°C ±3°C Relative Humidity: 90%~95% Duration: 48 hours and expose to room temperature for 6 hours

6.5 Temperature Shock Test

Temperature: 60°C /1hour → 25°C/3hours → -20°C/1hour → 25°C/3hours (1cycle)
Total cycle: 10 cycles

6.6 Drop Test

Standard Packaging From 75cm (Drop on hard wood or board of 5cm thick, three sides, six plain.)

6.7 Vibration Test

Vibration: 1000cycles /min. Amplitude: 1.5mm, Duration: 1 hour in each 3 axes

6.8 Reflow Test

Use recommendable reflow soldering condition (as shown in 5.1)

- (1) No abnormality should be found after reflow
- (2) Good soldering to meet soldering requirements

Note:

As this product is not protected from foreign material entering, please make sure that any foreign materials (e.g. magnetic powder, washing solvent, flux, corrosive gas) do not enter this product in your production processes. The functional degradation (e.g. SPL down) may occur if foreign material enter it.



Specification for Electro-Magnetic Buzzer (SMD Type)			Page 6 of 6	
			Des.	Chk.
Model No.:	MLT-1230	Part No.	4/10/2020	4/10/2020

7 Packing

