

Optocoupler, Phototransistor Output, Very High Isolation Voltage

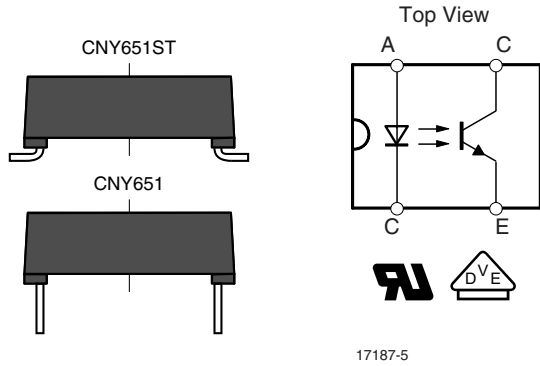

DESCRIPTION

The CNY651 Series are high isolation voltage TH and SMD version optocouplers consist of a phototransistor optically coupled to a gallium arsenide infrared-emitting diode in a 4 pin plastic package.

The single components are mounted opposite one another, providing a distance between input and output for highest safety requirements of > 3 mm.

VDE STANDARDS

These couplers perform safety functions according to the following equipment standards:

- **DIN EN 60747-5-5 (VDE 0884-5)**
Optocoupler for electrical safety requirements

FEATURES

- Rated recurring peak voltage (repetitive)
 $V_{IORM} = 1450 V_{peak}$
- Thickness through insulation ≥ 3 mm
- Creepage current resistance according to VDE 0303/IEC 60112 comparative tracking index: **CTI ≥ 475**
- Moisture sensitivity level MSL4
- Follow defined storage and soldering requirements for CNY651ST devices
- Material categorization:
for definitions of compliance please see www.vishay.com/doc?99912



APPLICATIONS

- Solar and wind power diagnostic, monitoring, and communication equipment
- Welding equipment
- High voltage motors
- Switch-mode power supplies
- Line receiver
- Computer peripheral interface
- Microprocessor system interface
- Circuits for safe protective separation against electrical shock according to safety class II (reinforced isolation):
 - for appl. class I to IV at mains voltage ≤ 300 V
 - for appl. class I to IV at mains voltage ≤ 600 V
 - for appl. class I to III at mains voltage ≤ 1000 V according to DIN EN 60747-5-5 (VDE 0884-5)

AGENCY APPROVALS

Safety application model number covering all products in this datasheet is CNY651. This model number should be used when consulting safety agency documents.

- DIN EN 60747-5-5 (VDE 0884-5)
- UL1577, file no. E76222
- VDE related features:
 - rated impulse voltage (transient overvoltage),
 $V_{IOTM} = 12 kV_{peak}$
 - isolation test voltage (partial discharge test voltage),
 $V_{pd} = 2.8 kV_{peak}$

ORDERING INFORMATION			
C	N	Y	6
PART NUMBER			
5	1	X	X
PACKAGE OPTION			
X	X	X	S
CTR BIN			
T			
		CNY651	CNY651ST
		15.24 mm	15.24 mm
AGENCY CERTIFIED/PACKAGE	CTR (%)		
	5 mA		
UL, VDE	50 to 150	100 to 300	
DIP-4 HV, 600 mil high isolation distance	-	CNY651AGR	
SMD-4 HV, 600 mil high isolation distance	CNY651AYST	CNY651AGRST	

ABSOLUTE MAXIMUM RATINGS ($T_{amb} = 25\text{ }^{\circ}\text{C}$, unless otherwise specified)				
PARAMETER	TEST CONDITION	SYMBOL	VALUE	UNIT
INPUT				
Reverse voltage		V_R	5	V
Forward current		I_F	75	mA
Forward surge current	$t_p \leq 10\text{ }\mu\text{s}$	I_{FSM}	1.5	A
Power dissipation		P_{diss}	120	mW
Junction temperature		T_j	125	$^{\circ}\text{C}$
OUTPUT				
Collector emitter voltage		V_{CEO}	32	V
Emitter collector voltage		V_{ECO}	7	V
Collector current		I_C	50	mA
Collector peak current	$t_p/T = 0.5, t_p \leq 10\text{ ms}$	I_{CM}	100	mA
Power dissipation		P_{diss}	130	mW
Junction temperature		T_j	125	$^{\circ}\text{C}$
COUPLER				
DC isolation test voltage CNY651A...ST	$t = 1\text{ s}$	V_{ISO}	13.9	kV
Total power dissipation		P_{tot}	250	mW
Ambient temperature range		T_{amb}	-40 to +110	$^{\circ}\text{C}$
Storage temperature range		T_{stg}	-40 to +110	$^{\circ}\text{C}$
Soldering temperature	2 mm from case, $\leq 10\text{ s}$	T_{slid}	260	$^{\circ}\text{C}$

Note

- Stresses in excess of the absolute maximum ratings can cause permanent damage to the device. Functional operation of the device is not implied at these or any other conditions in excess of those given in the operational sections of this document. Exposure to absolute maximum ratings for extended periods of the time can adversely affect reliability.

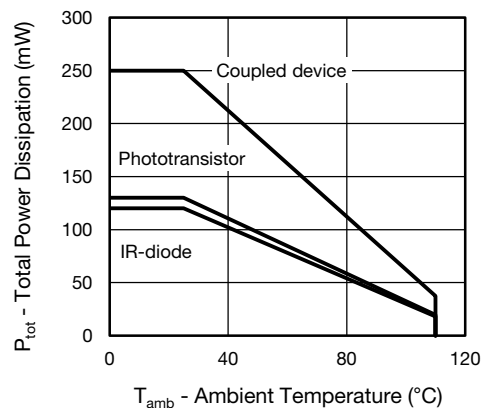

Fig. 1 - Total Power Dissipation vs. Ambient Temperature



ELECTRICAL CHARACTERISTICS ($T_{amb} = 25\text{ }^{\circ}\text{C}$, unless otherwise specified)						
PARAMETER	TEST CONDITION	SYMBOL	MIN.	TYP.	MAX.	UNIT
INPUT						
Forward voltage	$I_F = 50\text{ mA}$	V_F		1.32	1.6	V
Junction capacitance	$V_R = 0\text{ V}$, $f = 1\text{ MHz}$	C_j		50		pF
OUTPUT						
Collector emitter voltage	$I_C = 1\text{ mA}$	V_{CEO}	32			V
Emitter collector voltage	$I_E = 100\text{ }\mu\text{A}$	V_{ECO}	7			V
Collector emitter leakage current	$V_{CE} = 20\text{ V}$, $I_F = 0\text{ mA}$	I_{CEO}			200	nA
COUPLER						
Collector emitter saturation voltage	$I_F = 10\text{ mA}$, $I_C = 1\text{ mA}$	V_{CEsat}			0.3	V
Cut-off frequency	$V_{CE} = 5\text{ V}$, $I_F = 10\text{ mA}$, $R_L = 100\text{ }\Omega$	f_c		110		kHz
Coupling capacitance	$f = 1\text{ MHz}$	C_k		0.3		pF

Note

- Minimum and maximum values are testing requirements. Typical values are characteristics of the device and are the result of engineering evaluation. Typical values are for information only and are not part of the testing requirements.

CURRENT TRANSFER RATIO ($T_{amb} = 25\text{ }^{\circ}\text{C}$, unless otherwise specified)							
PARAMETER	TEST CONDITION	BIN	SYMBOL	MIN.	TYP.	MAX.	UNIT
I_C/I_F	$V_{CE} = 5\text{ V}$, $I_F = 5\text{ mA}$	AY.	CTR	50		150	%
		AGR.	CTR	100		300	%

SAFETY AND INSULATION RATINGS				
PARAMETER		SYMBOL	VALUE	UNIT
MAXIMUM SAFETY RATINGS				
Output safety power		P_{SO}	250	mW
Input safety current		I_{si}	120	mW
Safety temperature		T_S	150	$^{\circ}\text{C}$
Comparative tracking index		CTI	475	
INSULATION RATED PARAMETERS				
Maximum withstanding isolation voltage		V_{ISO}	8200	V_{RMS}
Maximum transient isolation voltage		V_{IOTM}	12 000	V_{peak}
Maximum repetitive peak isolation voltage		V_{IORM}	1450	V_{peak}
Insulation resistance	$T_{amb} = 25\text{ }^{\circ}\text{C}$, $V_{DC} = 500\text{ V}$	R_{IO}	$\geq 10^{12}$	Ω
Isolation resistance	$T_{amb} = 100\text{ }^{\circ}\text{C}$, $V_{DC} = 500\text{ V}$	R_{IO}	$\geq 10^{11}$	Ω
Climatic classification (according to IEC 68 part 1)			40/110/21	
Environment (pollution degree in accordance to DIN VDE 0109)			2	
Creepage			≥ 14	mm
Insulation thickness		DTI	3	mm

Note

- According to DIN EN 60747-5-5 (see figure 2). This optocoupler is suitable for safe electrical isolation only within the safety ratings. Compliance with the safety ratings shall be ensured by means of suitable protective circuits.

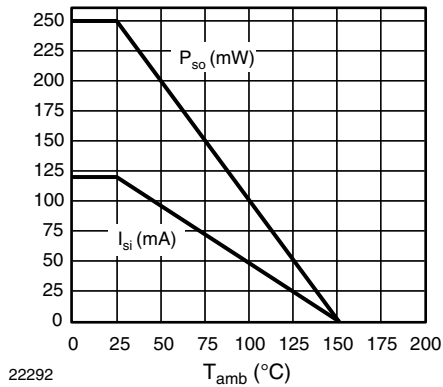

Fig. 2 - Safety Derating Diagram

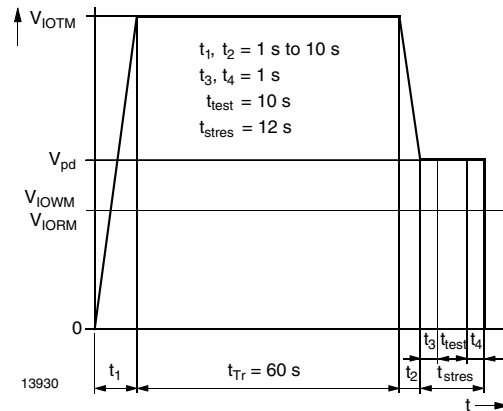

Fig. 3 - Test Pulse Diagram for Sample Test According to DIN EN 60747-5-5 (VDE 0884-5); IEC60747-5-5

SWITCHING CHARACTERISTICS						
PARAMETER	TEST CONDITION	SYMBOL	MIN.	TYP.	MAX.	UNIT
Delay time	$V_S = 5$ V, $I_C = 5$ mA, $R_L = 100$ Ω , (see figure 3)	t_d		2.6		μ s
Rise time	$V_S = 5$ V, $I_C = 5$ mA, $R_L = 100$ Ω , (see figure 3)	t_r		2.4		μ s
Fall time	$V_S = 5$ V, $I_C = 5$ mA, $R_L = 100$ Ω , (see figure 3)	t_f		2.7		μ s
Storage time	$V_S = 5$ V, $I_C = 5$ mA, $R_L = 100$ Ω , (see figure 3)	t_s		0.3		μ s
Turn-on time	$V_S = 5$ V, $I_C = 5$ mA, $R_L = 100$ Ω , (see figure 3)	t_{on}		5		μ s
Turn-off time	$V_S = 5$ V, $I_C = 5$ mA, $R_L = 100$ Ω , (see figure 3)	t_{off}		3		μ s
Turn-on time	$V_S = 5$ V, $I_F = 10$ mA, $R_L = 1$ k Ω , (see figure 4)	t_{on}		25		μ s
Turn-off time	$V_S = 5$ V, $I_F = 10$ mA, $R_L = 1$ k Ω , (see figure 4)	t_{off}		42.5		μ s

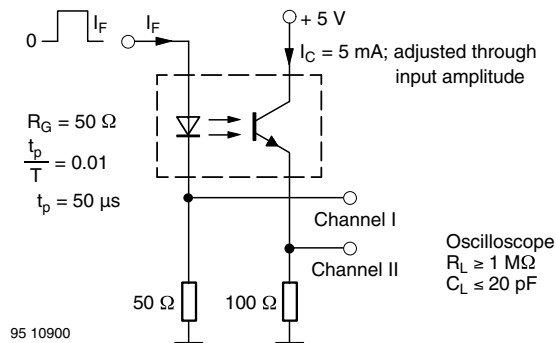

Fig. 4 - Test Circuit, Non-Saturated Operation

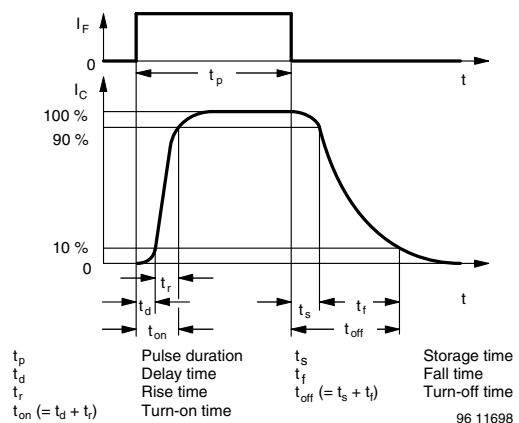

Fig. 6 - Switching Times

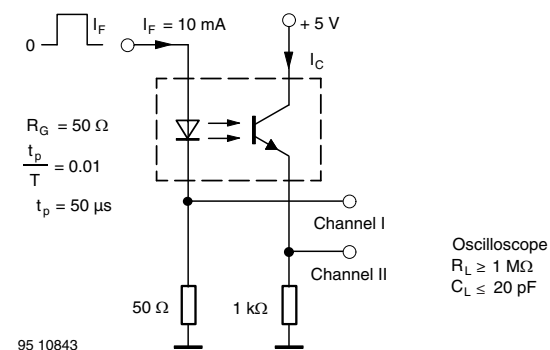

Fig. 5 - Test Circuit, Saturated Operation

TYPICAL CHARACTERISTICS ($T_{amb} = 25\text{ }^{\circ}\text{C}$, unless otherwise specified)

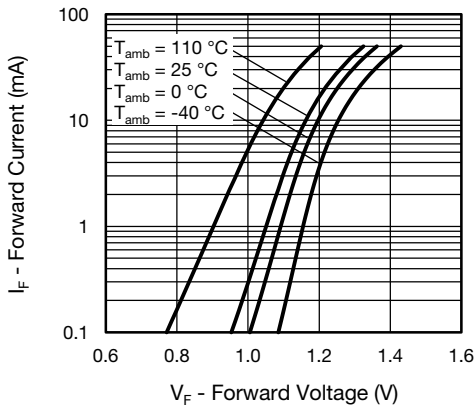

Fig. 7 - Forward Current vs. Forward Voltage

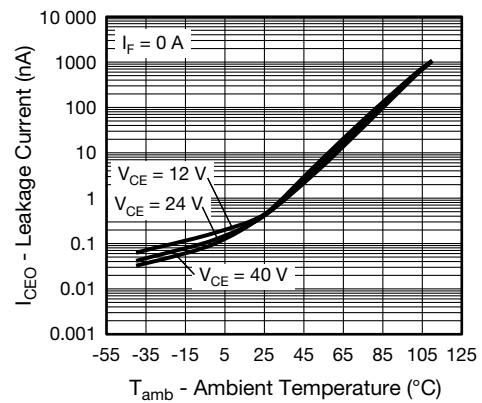

Fig. 10 - Leakage Current vs. Ambient Temperature

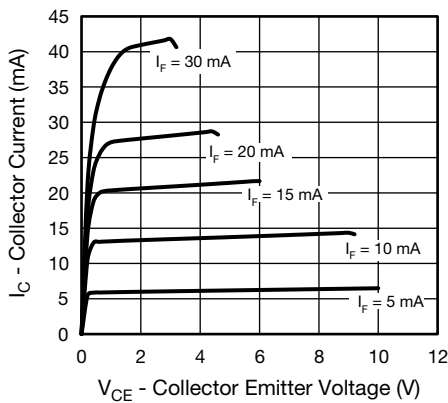

Fig. 8 - Collector Current vs. Collector Emitter Voltage (NS)

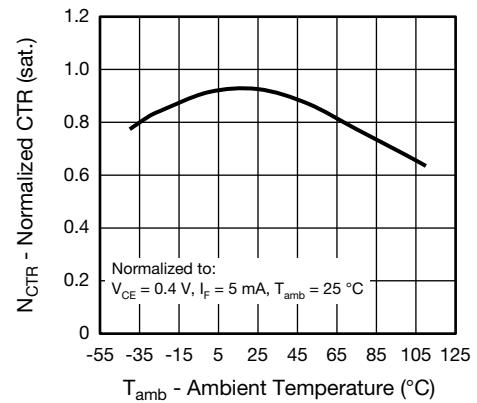

Fig. 11 - Normalized CTR (sat.) vs. Ambient Temperature

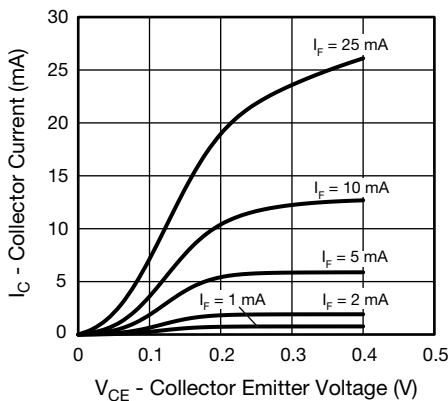

Fig. 9 - Collector Current vs. Collector Emitter Voltage

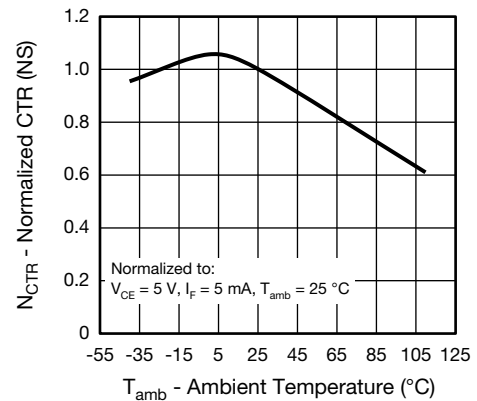

Fig. 12 - Normalized CTR (NS) vs. Ambient Temperature

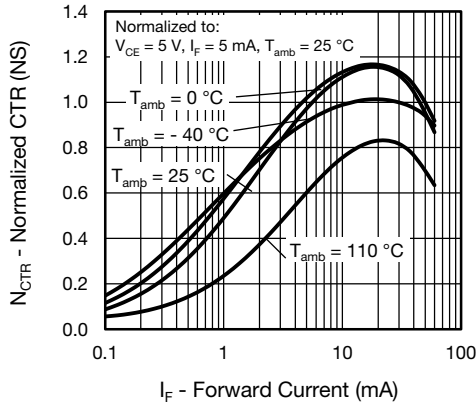

Fig. 13 - Normalized CTR (NS) vs. Forward Current

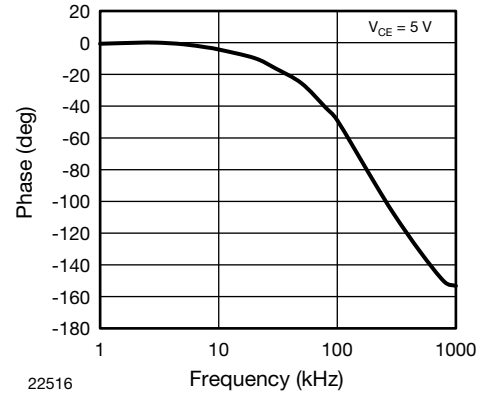

Fig. 16 - Phase Angle vs. F_{CTR}

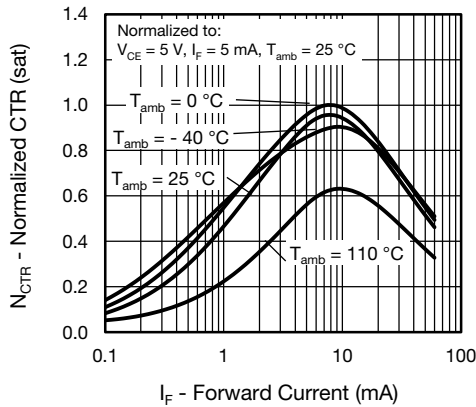

Fig. 14 - Normalized CTR (sat) vs. Forward Current

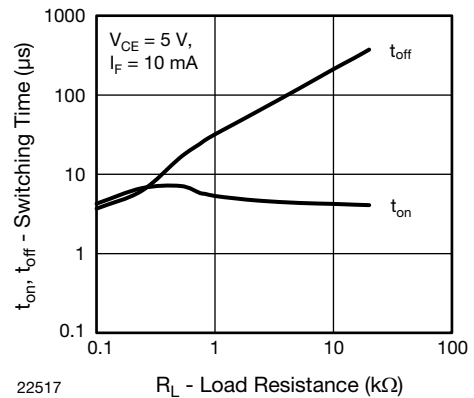

Fig. 17 - Switching Time vs. Load Resistance

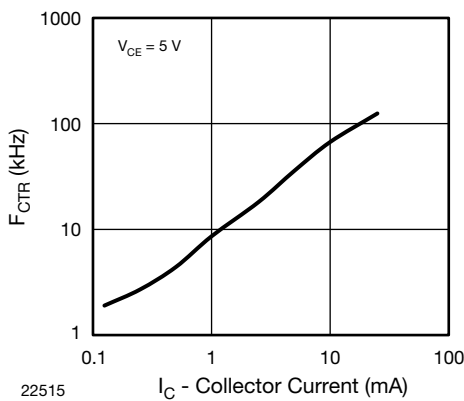
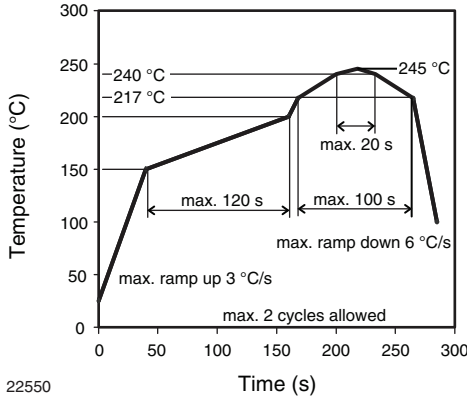

Fig. 15 - F_{CTR} vs. Collector Current

SOLDERING GUIDELINES

Soldering Condition

The CNY651AxST are lead (Pb)-free devices. They are suitable for reflow soldering. However due to large package size, the peak package body temperature should not go above 245 °C.



22550

Drypack

These devices have a moisture sensitivity level MSL4 thus they are packed in moisture barrier bags (MBB) to prevent moisture absorption during transportation and storage. Each bag contains a desiccant bag.

Floor Life

Floor life (time between soldering and removing from MBB) must not exceed the time indicated on MBB label:

Floor life: 72 h

Conditions: $T_{amb} < 30\text{ °C}$, $RH < 60\%$

Moisture sensitivity level 4, according to J-STD-020.

Drying

In case of moisture absorption devices should be baked before soldering according to the recommended conditions shown below

48 h at $125\text{ °C} \pm 5\text{ °C}$, $RH < 5\%$

(Not suitable for tape and reel)

In case the floor time has not exceeded 10 days the units can be baked in tape and reel according to the following conditions

168 h at $60\text{ °C} \pm 5\text{ °C}$, $RH < 5\%$

(Not suitable, if the floor time was exceeded by more than 10 days, or the allowed factory condition is exceeded)

CNY651 - DIP version device cannot go through reflow soldering hence wave soldering should be used. See absolute maximum ratings for soldering specifications.

PACKAGE DIMENSIONS in millimeters FOR CNY651A...ST

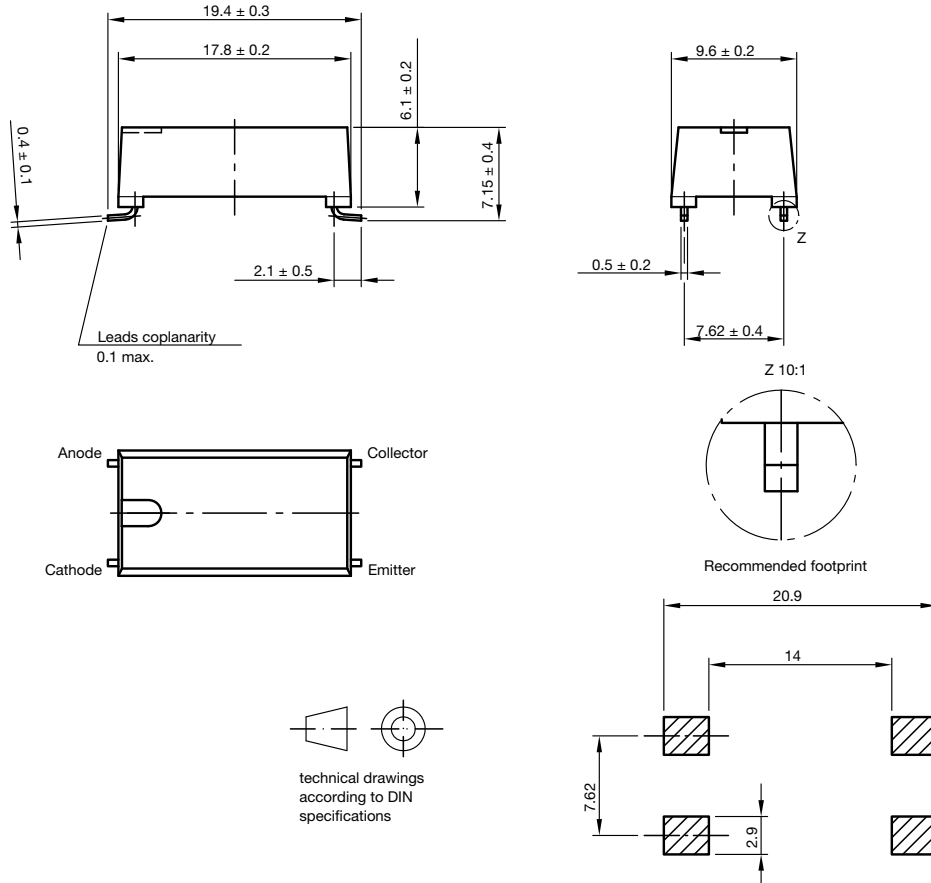

PACKAGE DIMENSIONS in millimeters FOR CNY651A...

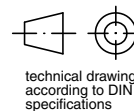
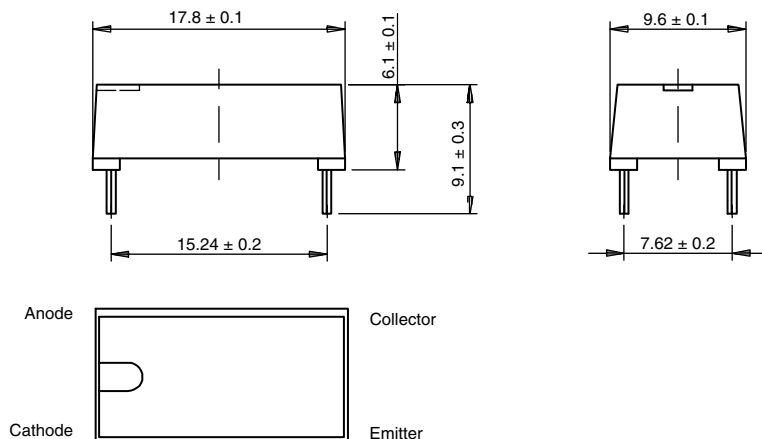

PACKAGE MARKING (Example of CNY651AYST)

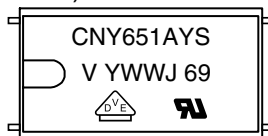

Note

- The "T" at the end of the product designation is not marked on the package

TUBE AND TAPE INFORMATION

TUBE INFORMATION			
TYPE	UNITS/TUBE	TUBES/BOX	UNITS/BOX
CNY651	30	35	1050

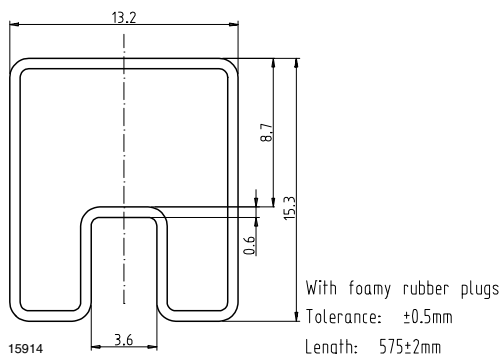
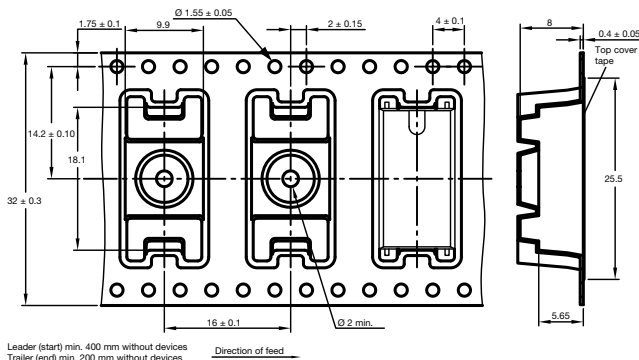

Fig. 18 - CNY651

TAPE DIMENSIONS in millimeters FOR CNY651A...ST





REEL DIMENSIONS in millimeters

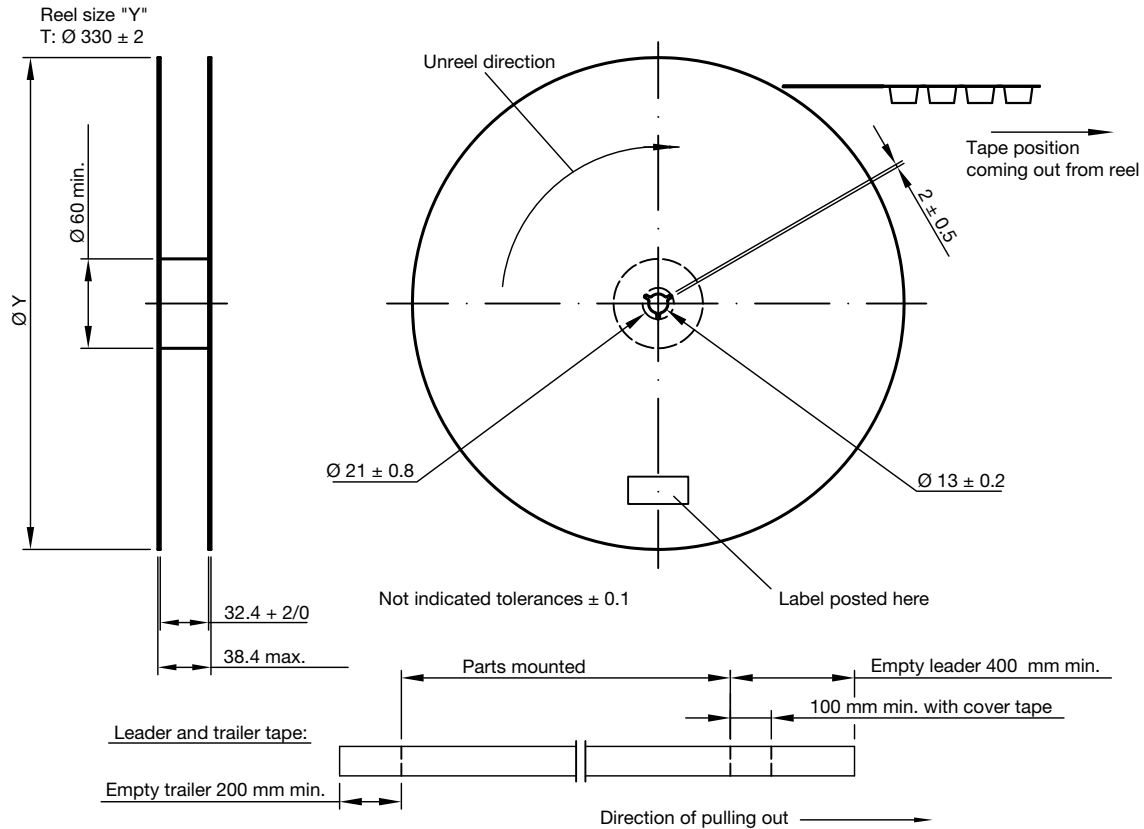

Fig. 19 - 400 Units per Reel, 2 Reels per Box



Disclaimer

ALL PRODUCT, PRODUCT SPECIFICATIONS AND DATA ARE SUBJECT TO CHANGE WITHOUT NOTICE TO IMPROVE RELIABILITY, FUNCTION OR DESIGN OR OTHERWISE.

Vishay Intertechnology, Inc., its affiliates, agents, and employees, and all persons acting on its or their behalf (collectively, "Vishay"), disclaim any and all liability for any errors, inaccuracies or incompleteness contained in any datasheet or in any other disclosure relating to any product.

Vishay makes no warranty, representation or guarantee regarding the suitability of the products for any particular purpose or the continuing production of any product. To the maximum extent permitted by applicable law, Vishay disclaims (i) any and all liability arising out of the application or use of any product, (ii) any and all liability, including without limitation special, consequential or incidental damages, and (iii) any and all implied warranties, including warranties of fitness for particular purpose, non-infringement and merchantability.

Statements regarding the suitability of products for certain types of applications are based on Vishay's knowledge of typical requirements that are often placed on Vishay products in generic applications. Such statements are not binding statements about the suitability of products for a particular application. It is the customer's responsibility to validate that a particular product with the properties described in the product specification is suitable for use in a particular application. Parameters provided in datasheets and / or specifications may vary in different applications and performance may vary over time. All operating parameters, including typical parameters, must be validated for each customer application by the customer's technical experts. Product specifications do not expand or otherwise modify Vishay's terms and conditions of purchase, including but not limited to the warranty expressed therein.

Except as expressly indicated in writing, Vishay products are not designed for use in medical, life-saving, or life-sustaining applications or for any other application in which the failure of the Vishay product could result in personal injury or death. Customers using or selling Vishay products not expressly indicated for use in such applications do so at their own risk. Please contact authorized Vishay personnel to obtain written terms and conditions regarding products designed for such applications.

No license, express or implied, by estoppel or otherwise, to any intellectual property rights is granted by this document or by any conduct of Vishay. Product names and markings noted herein may be trademarks of their respective owners.