

LI0603G221R-10

PHYSICAL DIMENSIONS:

A	1.60 [.063]	+ 0.15	-.006	[.006]
B	0.80 [.031]	+ 0.15	-.006	[.006]
C	0.80 [.031]	+ 0.15	-.006	[.006]
D	0.36 [.014]	+ 0.15	-.006	[.006]

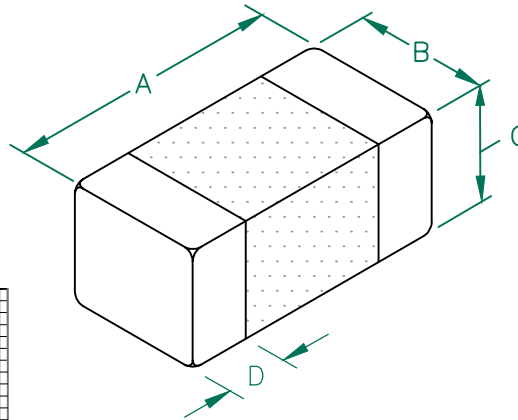

ELECTRICAL CHARACTERISTICS:

Z @ 100MHz (Ω)	DCR (Ω)	Rated Current
Nominal	220	
Minimum	165	
Maximum	275	700 mA

NOTES: UNLESS OTHERWISE SPECIFIED

1. TAPED AND REELED per CURRENT EIA SPECIFICATIONS 7" REELS, 4000 PCS/REEL.
2. TERMINATION FINISH IS 100% TIN.
3. COMPONENTS SHOULD BE ADEQUATELY PREHEATED BEFORE SOLDERING.
4. OPERATING TEMP. RANGE: -40°C~+125°C. (INCLUDING SELF-HEATING)

Z vs FREQUENCY
IMPEDANCE UNDER DC BIAS

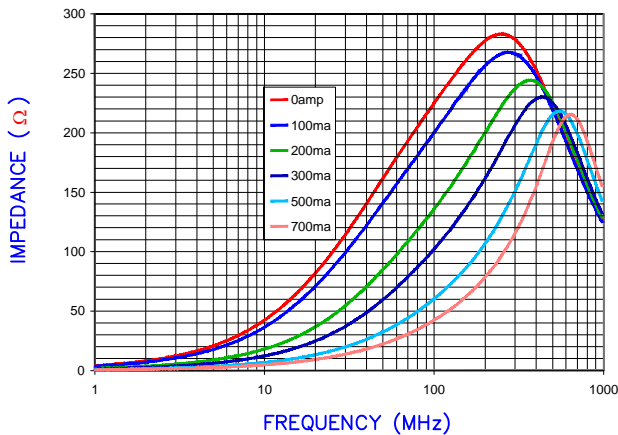

|Z|, R, AND X vs. FREQUENCY

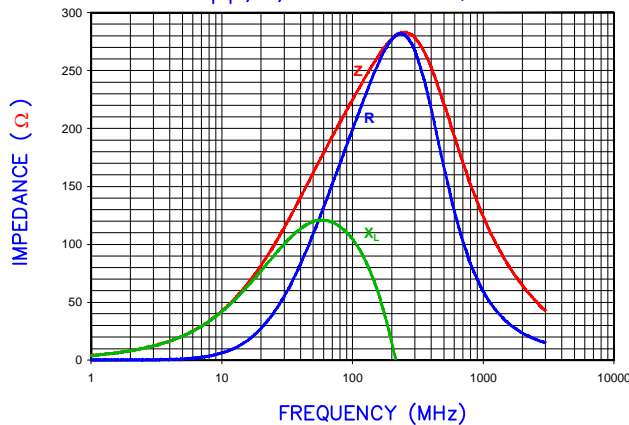

LAND PATTERNS FOR REFLOW SOLDERING

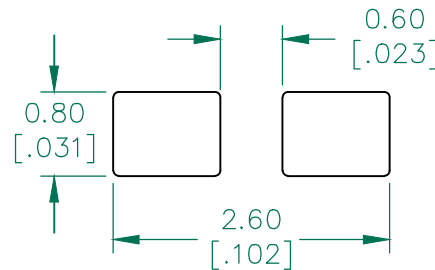

(For wave soldering, add 0.762 [.030] to this dimension)

RECOMMENDED SOLDERING CONDITIONS

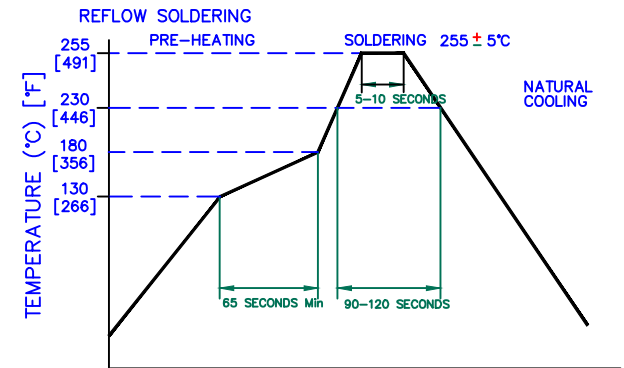

AGILENT E4991A RF Impedance/Material Analyzer
HP 16194A Test Fixture. TEST REF. 3235

RoHS

DIMENSIONS ARE IN mm [INCHES].				This print is the property of Laird Tech. and is loaned in confidence subject to return upon request and with the understanding that no copies shall be made without the written consent of Laird Tech. All rights to design or invention are reserved.			
PROJECT/PART NUMBER:				LAI0603G221R-10			
REV C				PART TYPE: CO-FIRE		DRAWN BY: TMB	
B UPDATE COMPANY LOGO ADD ROHS SYM		07/15/08		JRK DATE: 04/05/04		SCALE: - SHEET: 1 of 1	
A ORIGINAL DRAFT		04/05/04		TMB CAD #		TOOL # -	
REV DESCRIPTION				DATE INT			