

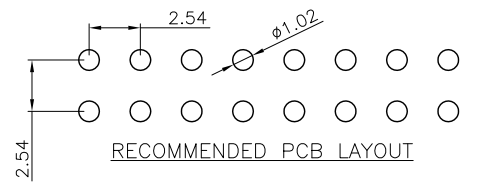

技术参数/Technical parameters

额定电流/Current Rating : 3AMP
 绝缘阻抗/Insulator Resistance : 1000MΩ Min.
 接触阻抗/Contact Resistance : 20mΩ Max.
 耐电压值/Voltage Resistance : AC 500V
 工作温度/Operating Temperature : -40℃ ~ +125℃
 金属材料/Metallic Material : Copper alloy
 金属处理/Metal Treatment : Ni+Gold Plate
 绝缘材料/Insulator Material : PBT UL94V-0
 耐焊接热/Resistance To Soldering Heat : 210° C ±5° C 10S MAX

PIN No.	DIM A	DIM B	PIN No.	DIM A	DIM B
2x2	2.54	5.58	2x21	50.80	53.84
2x3	5.08	8.12	2x22	53.34	56.38
2x4	7.62	10.66	2x23	55.88	58.92
2x5	10.16	13.20	2x24	58.42	61.46
2x6	12.70	15.74	2x25	60.96	64.00
2x7	15.24	18.28	2x26	63.50	66.54
2x8	17.78	20.82	2x27	66.04	69.08
2x9	20.32	23.36	2x28	68.58	71.62
2x10	22.86	25.90	2x29	71.12	74.16
2x11	25.40	28.44	2x30	73.66	76.70
2x12	27.94	30.98	2x31	76.20	79.24
2x13	30.48	33.52	2x32	78.74	81.78
2x14	33.02	36.06	2x33	81.28	84.32
2x15	35.56	38.60	2x34	83.82	86.86
2x16	38.10	41.14	2x35	86.36	89.40
2x17	40.64	43.68	2x36	88.90	91.94
2x18	43.18	46.22	2x37	91.44	94.48
2x19	45.72	48.76	2x38	93.98	97.02
2x20	48.26	51.30	2x39	96.52	99.56
			2x40	99.06	102.10

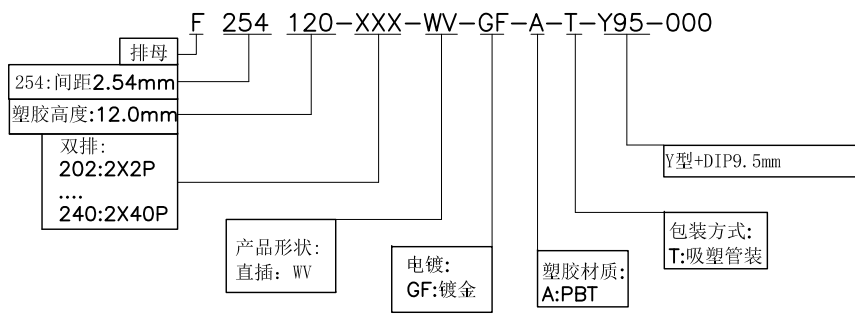
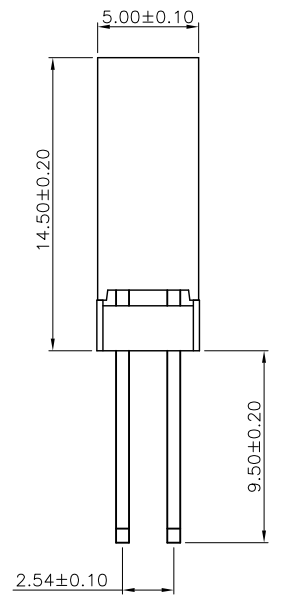
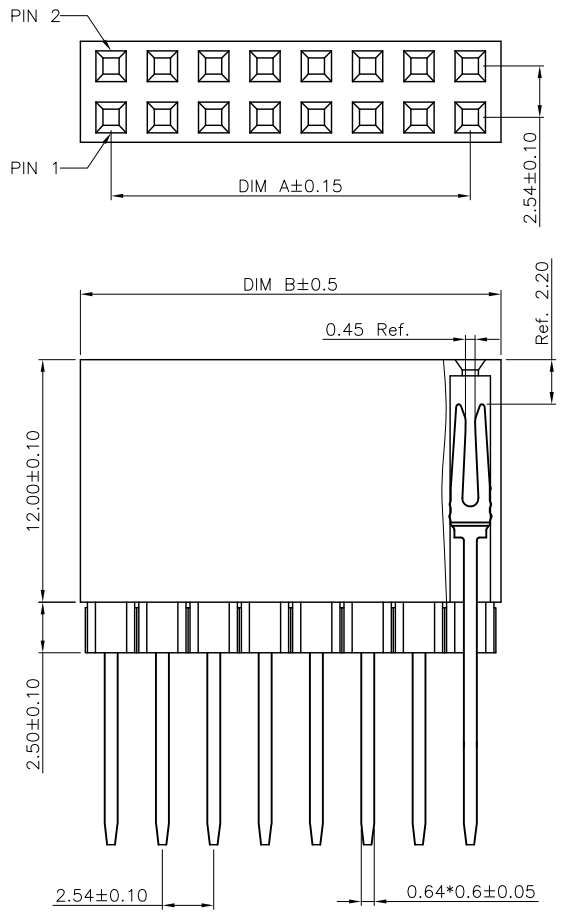

TOLERANCE UNLESS OTHERWISE SPECIFIED		东莞市柏洲电子有限公司 Dongguan Bzoc Electronics, Ltd	
.X± 0.35	X.'± 1.5'	APR. AX.T	TITLE: 2.54mm Female Header H:12mm+2.5mm PC104 DIP:9.50mm AU PA6T
.XX± 0.25	.X'± 1.0'	CHK. Y.L	PART NO.
.XXX± 0.15	.XX'± 0.5'	DRA. Y.L	PROJ. UNITS. MM SCALE: 1:1 CUSTOMER DRAWING SHEET. 1 / 1

A0	FIRST RELEASE	YANG	2020.02.20
REV.	ECN. NO.	APR.	DATE