

Polymer Li-ion Battery  
Specification

聚合物锂离子电池说明书

MODEL/型号: LC502222-200mAh

制定人 Prepared by	审核人 Checked by	批准人 Approved by

Customer Name/客户名称:

Customer Approval 客户确认栏

Confirmation opinions 确认意见:

Company Stamp(盖章):

Signature/Date(签名/日期):

### 1. Scope (适用范围)

Mentioned in this manual applies to the book, SHENZHEN BULECHAO TECHNOLOGY CO.,LTD, manufacture of batteries

本说明书适用于本书中所提及的、深圳市蓝巢科技有限公司制造的电池。

### 2. Dimensions of battery pack 电池组尺寸

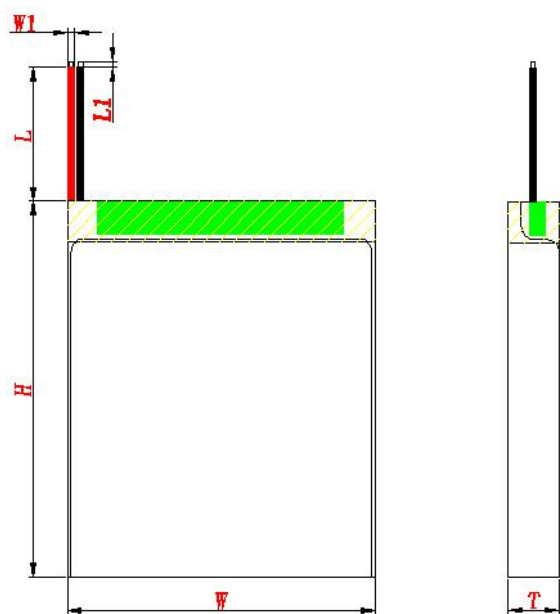

H (厚度)	5.0 (max)	mm
W (宽度)	22.0(max)	mm
L (长度)	24.0(max)	mm
L1 (线长)	20±2.0	mm
W1 (线径)	0.6	mm
L2 (剥线头)	1.0±0.2	mm

### 3. Battery portfolio primarily BOM 电池组合主要物料清单

No. 序号	Item 项目	Criteria 规格	Remarks 备注
1	Polymer electric core 聚合物电芯	502222-200mAh	A 品
2	Protection board 保护板	Y1A+8205	精工
3	Interface mode 接口方式 (引线)	3302-AWG32#	左出线
4	Printing content 喷码内容	-LC 502222 3.7V 200mAh +0.74Wh 日期	

#### 4. 保护板元器件清单

序号	物料名称	物料代号	物料规格	用量	备注
1	保护 IC	U1	精工 D 系列	1	
2	MOSFET	U2	8205	1	
3	贴片电阻	R1	470Ω ±5%/0603	1	
4	贴片电阻	R2	2KΩ ±5%/0603	1	
5	热敏电阻	R3	/	/	
6	贴片电容	C1	0.1μF/±20%/0402/50V	1	
7	印制电路板	PCB	TBD-BFN-001 代 16mm*3.8mm*0.6mm	1	

#### 5. 保护板原理图

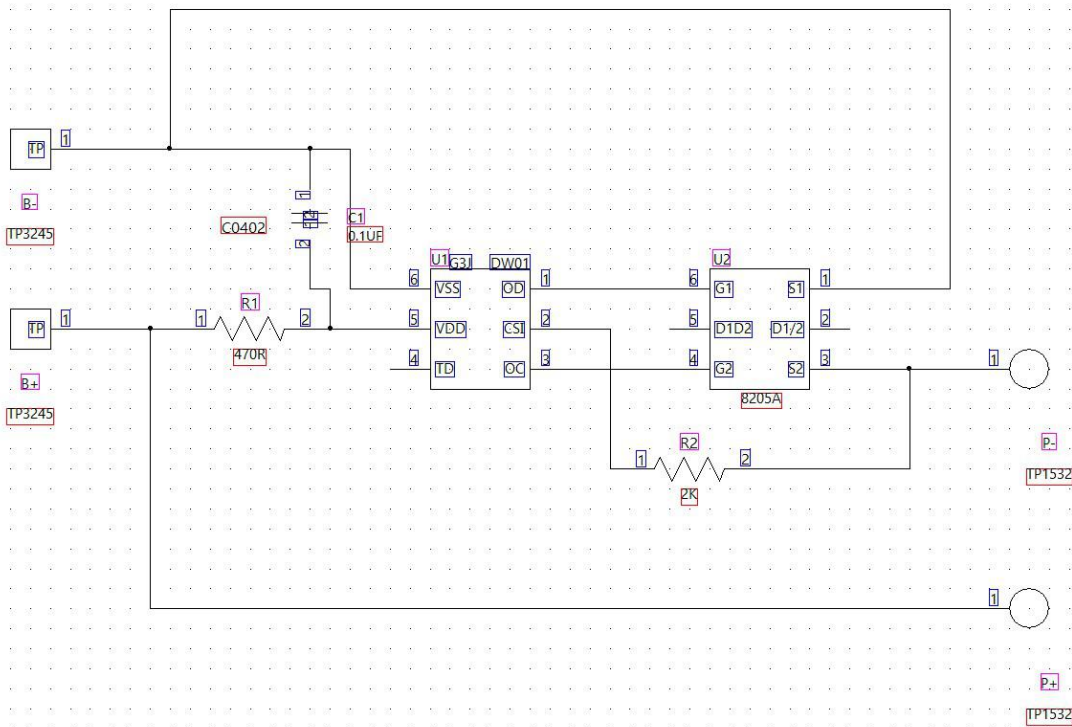

6. Specifications of battery pack 电池组规格

No. (序号)	Item (项目)	General Parameter (常规参数)	Remark (备注)
1	Outline Dimensions 电芯尺寸	厚 5mm*宽 22mm*22mm	
2	Nominal Capacity (标称容量)	200mAh	Discharge:0.2CmA , 0.2C 放电
3	Nominal Voltage 额定电压	3.7V	
4	AC Impedance Resistance 内阻	≤220mΩ	
5	Charging Current (Std.) 标准充电电流	Constant Current 0.2C <sub>5</sub> A Constant Voltage 4.2V 0.01 C <sub>5</sub> A cut-off (持续电流: 0.2C <sub>5</sub> A 持续电压: 4.2V 截止电流: 0.01 C <sub>5</sub> A)	
6	Charging Current(Max.) 最大充电电流	1.0 C <sub>5</sub> A	常温 25℃
7	Charging Voltage 充电电压	4.2±0.05V	
8	Discharging Current(Std) 标准放电电流	Constant current 0.2 C <sub>5</sub> A end voltage 3.0V (持续电流: 0.2C <sub>5</sub> A 截止电压: 3.0V)	
9	Discharging Current(Max) 最大放电电流	1.0C <sub>5</sub> A	
10	Discharge Cut-off Voltage 放电 截至电压	3.0V	
11	Operating Temperature 工作温度	0~+45℃	
		-20~+60℃	
12	Storage Temperature 存储温度	-20~+45℃	
		-20~+35℃	
13	Storage Voltage 存储电压	3.70~3.90V	
14	OverCharge Protection Voltage 过充保护电压	4.25V±0.05V	
15	OverCharge Recovery Voltage 过 充恢复电压	4.15V±0.05V	
16	Over-discharge Protection Voltage 过放保护电压(V)	3.0±0.05 V	
17	The limit protection Current 限流保护电流(A)	1.5-2.5A	
18	Storage humidity (储存湿度)	≤ 75%	

## 7. Performance And Test Conditions (电池性能及测试条件)

### 7.1 Standard Test Conditions (标准测试条件)

Test should be conducted with new batteries within one week after shipment from our factory and the cells shall not be cycled more than five times before the test. Unless otherwise specified, test and measurement shall be done under temperature of  $20 \pm 5^\circ\text{C}$  and relative humidity of 45~85%. If it is judged that the test results are not affected by such conditions, the tests may be conducted at temperature  $15 \sim 30^\circ\text{C}$  and humidity 25~85%RH.

测试必须使用出厂时间不超过一个星期的新电池,且未进行过五次以上的充放电循环。除非特别说明,否则测试会在温度  $20 \pm 5^\circ\text{C}$ ,相对湿度 45~85%的条件下进行。如果经鉴定测试结果不受上述条件影响,测试也可以在温度  $15 \sim 30^\circ\text{C}$ ,相对湿度 25~85%RH的条件下进行。

### 7.2 Measuring Instrument or Apparatus (测量器具及设备)

#### 7.2.1 Dimension Measuring Instrument (尺寸测量器具)

The dimension measurement shall be implemented by instruments with equal or more precision scale of 0.01mm.

尺寸测量器具的精度等级应不小于 0.01 mm。

#### 7.2.2 Voltmeter (伏特计)

Standard class specified in the national standard or more sensitive class having inner impedance more than  $10\text{k}\Omega/\text{V}$

按照国家标准指定规格等级或采用灵敏度更高的,测量电压时内阻不应小于  $10\text{k}\Omega/\text{V}$ 。

#### 7.2.3 Ammeter (安培计)

Standard class specified in the national standard or more sensitive class. Total external resistance including ammeter and wire is less than  $0.01\Omega$ .

按照国家标准指定规格等级或采用灵敏度更高的,包括电流表及电线在内的总外阻应小于  $0.01\Omega$ 。

#### 7.2.4 Impedance Meter (电阻计)

Impedance shall be measured by a sinusoidal alternating current method (1kHz LCR meter).

内阻测试仪测量原理应为交流阻抗法 (1kHz LCR)。

### 7.3 Standard Charge\Discharge (标准充放电)

#### 7.3.1 Standard Charge: Test procedure and its criteria are referred as follows:

标准充电: 测试过程及标准如下:

$0.2C_5A = 500\text{mA}$

Charging shall consist of charging at a  $0.2C_5A$  constant current rate until the cell reaches 4.2V. The cell shall then be charged at constant voltage of 4.2 volts while tapering the charge current. Charging shall be terminated when the charging current has tapered to  $0.01 C_5A$ . Charge time : Approx 6h, The cell shall demonstrate no permanent degradation when charged between  $0^\circ\text{C}$  and  $45^\circ\text{C}$ .

电池先  $0.2C_5A$  恒流充至 4.2V, 当充电电流逐渐减小时再以 4.2V 恒压充至电流减小到  $0.01 C_5A$ , 充电时间大约为 6 个小时。在  $0^\circ\text{C}$ - $45^\circ\text{C}$  内充电电池应没有永久损害。

#### 7.3.2 Standard Discharge (标准放电)

$0.2C_5A = 500\text{mA}$

Cells shall be discharged at a constant current of  $0.2 C_5A$  to 3.0 volts @  $20^\circ \pm 5^\circ\text{C}$

电池以  $0.2 C_5A$  恒流放电至 3.0V @  $20^\circ \pm 5^\circ\text{C}$

7.3.3 If no otherwise specified, the rest time between Charge and Discharge amount to 30min.

如果没有特别说明, 电池充放电间隔时间为 30 分。

7.4 Appearance (外观)

There shall be no such defect as flaw, crack, rust, leakage, which may adversely affect commercial value of battery.

电池外观应没有划伤、破裂、污渍、生锈、漏液等影响市场价值的缺陷存在。

7.5 Initial Performance Test (初始性能测试)

Item (项目)	Test Method and Condition (测试方法及条件)	Requirements (要求)
Open-Circuit Voltage (开路电压)	The open-circuit voltage shall be measured within 24 hours after standard charge. (标准充电后 24 小时内测量开路电压)	$\geq 4.15V$
Internal impedance (初始内阻)	Internal resistance measured at AC 1KHz after 50% charge. (半充电状态下, 测量其 AC 1KHz 下的交流阻抗)	$\leq 220m\Omega$
Minimal Rated Capacity (最小额定容量)	The capacity on 0.2C <sub>5</sub> A discharge till the voltage tapered to 3.0V shall be measured after rested for 30min then finish standard charge. (标准充电后, 搁置 30min, 测量 0.2C 放电至 3.0V 截止电压所放出的容量)	Discharge Capacity (放电容量) $\geq 200mAh$

7.6 Temperature Dependence of discharge capacity (放电温度特性)

Cells shall be charged per 5.3.1 and discharged @0.2 C<sub>5</sub>A to 3.0volts. Except to be discharged at temperatures per Table 3. Cells shall be stored for 3 hours at the test temperature prior to discharging and then shall be discharged at the test temperature. The capacity of a cell at each temperature shall be compared to the capacity achieved at 23 °C and the percentage shall be calculated. Each cell shall meet or exceed the requirements of Table 3.

电池按 3.3.1 规定充电。按表 3 的温度中放电, 电池必须先在该试验温度中放置 3 个小时。在每一个温度中的放电容量应不小于表 3 的要求。

Table 3 (表 3)

Discharge Temperature (放电温度)	-10°C	0°C	50°C	80°C
Discharge Capacity (0.2 C <sub>5</sub> A) (放电容量/0.2 C <sub>5</sub> A)	60%	80%	100%	90%

7.7 Cycle Life and Leakage-Proof (循环寿命及漏液试验)

Table 4 (表4)

No. (序号)	Item (项目)	Criteria (标准)	Test Conditions (测试条件)
1	Cycle Life (循环寿命) (0.2C <sub>5</sub> A)	Higher than 70% of the Initial Capacities of the Cells (初始容量的70%)	Carry out 300cycle  Charging/Discharging in the below condition.  ◆Charge:Standard Charge, per 5.3.1  ◆Discharge:0.2 C <sub>5</sub> A to 3.0V  ◆Rest Time between charge/discharge:30min.  ◆Temperature:60℃  循环300次  充放电按以下条件:  ◆充电:标准充电,按5.3.1规定  ◆放电:0.2 C <sub>5</sub> A放至3.0V  ◆搁置:30min.  ◆温度:25℃
2	Leakage- Proof (漏液试 验)	No leakage (visual inspection) (没有漏液/目测)	After full charge with standard charge, store at 60±3℃, 60±10%RH for 1month.  标准充电条件下充满电后在温度60± 3℃,湿度60±10%RH下储存一个月

8. Mechanical characteristics and Safety Test (安全测试及机械特性)

Mechanical Performance 机械特性

No. (序号)	Items (项目)	Test Method and Condition (测试方法及条件)	Criteria (标准)
1	Vibration Test 振动测试	After standard charging, fixed the cell to vibration table and subjected to vibration cycling that the frequency is to be varied at the rate of 1Hz per minute between 10Hz and 55Hz, the excursion of the vibration is 1.6mm. The cell shall be vibrated for 30 minutes per axis of XYZ axes.  将标准充电后的电芯固定在振动台上, 沿 X、Y、Z 三个方向各振动 30 分钟, 振幅 1.6mm, 振动频率为 10Hz~55Hz, 每分钟变化 1Hz。	No leakage 无泄漏  No fire 不起火
2	Drop Test 跌落测试	The cell is to be dropped from a height of 1 meter twice onto concrete ground.  将标准充电后的电芯从 1 米高度跌落至混凝土地面 2 次	No explosion, No fire, no leakage.  无爆炸、无起火、无泄漏

Safety Performance 安全性能

Item (项目)	Battery Condition (电池要求)	Test Method (测试方法)	Requirements (要求)
Crush (挤压试验)	Fresh, Fully charged (充满电的新电池)	Crush between two flat plates. Applied force is about 13kN(1.72Mpa) for 30min.  (电池放置在两块平面金属板间, 施加 13KN (1.72Mpa) 的作用力, 且持续保持 30 分钟)	No explosion, No fire (无起火无爆炸)



<p>Short Circuit (短路试验 20℃)</p>	<p>Fresh, Fully charged (充满电的 新电池)</p>	<p>Each test sample battery, in turn, is to be short-circuited by connecting the (+) and (-) terminals of the battery with a Cu wire having a maximum resistance load of 0.1Ω. Tests are to be conducted at room temperature (20±2℃ ).  (在常温下约 20±2℃ 依次把每个样品电池的正负极用铜线连接起来使电池外部短路—线路总电阻不超过 0.1Ω)</p>	<p>No explosion,  No fire The Temperature of the surface of the Cells are lower than 150℃  (无起火无爆炸 电池表面温度应低于 150℃)</p>
<p>Short Circuit (短路试验 60℃)</p>	<p>Fresh, Fully charged (充满电的 新电池)</p>	<p>Each test sample battery, in turn, is to be short-circuited by connecting the (+) and (-) terminals of the battery with a Cu wire having a maximum resistance load of 0.1Ω. Tests are to be conducted at temperature (60±2℃ ).  (在常温下约 60±2℃ 依次把每个样品电池的正负极用铜线连接起来使电池外部短路—线路总电阻不超过 0.1Ω)</p>	<p>No explosion,  No fire The Temperature of the surface of the Cells are lower than 150℃  (无起火无爆炸 电池表面温度应低于 150℃)</p>
<p>Impact (冲击试验)</p>	<p>Fresh, Fully charged (充满电的 新电池)</p>	<p>A 56mm diameter bar is inlaid into the bottom of a 10kg weight. And the weight is to be dropped from a height of 1m onto a sample battery and then the bar will be across the center of the sample. (用一条直径为 56mm 的圆棒放置在电池中央, 将一 10Kg 的重锤从 1m 的高度垂直落下在电池的中心位置)</p>	<p>No explosion,  No fire (无起火无爆炸)</p>
<p>Forced Discharge (过放试验)</p>	<p>Fresh, Fully charged (充满电的 新电池)</p>	<p>Discharge at a current of 1 C<sub>5</sub>A for 2.5h.  (以 1C<sub>5</sub>A 的电流放电 2.5 小时)</p>	<p>No explosion,  No fire (无起火无爆炸)</p>

## 9. Handling of Cells (电池操作注意事项)

### 9.1 Consideration of strength of film package(包装薄膜注意事项)

#### 1) Soft Aluminium foil (铝箔软包装)

Easily damaged by sharp edge parts such as pins and needles, Ni-tabs, comparing with metal-can-cased LIB.

相对于金属壳的方形电池, 铝箔软包装比较容易被锐利部件刺损, 如针尖、镍带。

#### 2). Sealed edgemay be damaged by heat above 100° C, bend or fold sealed edge.

封边被加热到 100° C 以上以及弯折封边都容易使封边受损。

### 9.2 Prohibition short circuit (禁止电池短路)

Never make short circuit cell. It generates very high current which causes heating of the cellsand may cause electrolyte leakage, gassing or explosion that are very dangerous.

The LIP tabs may be easily short-circuited by putting them on conductive surface. Such outershort circuit may lead to heat generation and damage of the cell. An appropriate circuitry with PCM shall be employed to protect accidental short circuit of thebattery pack.

避免电池短路。短路会产生很高的电流而使电池发热以及电解液泄漏, 产生有毒气体或爆炸是非常危险的。极片连接在导电物体表面很容易短路, 外部短路会导致发热及损害电池。选一个适当的保护电路可以在意外短路时保护电池。

### 9.3 Mechanical shock (机械撞击)

LIP cells have less mechanical endurance than metal-can-cased LIB.

Falling, hitting, bending, etc. may cause degradation of LIP characteristics.

聚合物电池比金属壳方形电池的机械耐久性更小。

跌落、碰撞、弯曲等等都可能降低聚合物电池的性能。

### 9.4 Handling of tabs (极片操作注意事项)

The battery tabs are not so stubborn especially for aluminum tab.

Don' t bend tab.

Do not bend tabs unnecessarily.

极片的机械强度并非异常坚固, 特别是铝片。没有必要时禁止弯折极片。

## 10. Notice for Assembling Battery Pack (电池装配注意事项)

Shocks, high temperature, or contacts of sharp edge components should not be allowed in battery pack assembling process.

在电池装配过程中不允许撞击、高温或接触尖锐部分。

## 11. Others (其它)

### 11.1. Cell connection (电池连接)

1) Direct soldering of wire leads or devices to the cell is strictly prohibited.

2) Lead tabs with pre-soldered wiring shall be spot welded to the cells.

Direct soldering may cause damage of components, such as separator and insulator, by heat generation.

1、严禁直接焊接引线或设备到电池上。

2、极片在焊接引线之前应该先点焊到电池上, 直接与电池热焊接, 产生的热量会使电池的隔离体及绝缘体受损。

### 11.2 Prevention of short circuit within a battery pack (电池内部的短路预防)

Enough insulation layers between wiring and the cells shall be used to maintain extra safety protection.

The battery pack shall be structured with no short circuit within the battery pack, which may cause generation of smoke or firing.

在电池和引线之间应该有足够的绝缘层用于安全保护。电池的包装构成应没有导致起烟起火的短路情况。

### 11.3 Prohibition of disassembly (禁止拆卸)

#### 1) Never disassemble the cells

The disassembling may generate internal short circuit in the cell, which may cause gassing, firing, explosion, or other problems.

#### 2) Electrolyte is harmful

LIP battery should not have liquid from electrolyte flowing, but in case the electrolyte come into contact with the skin, or eyes, physicians shall flush the electrolyte immediately with fresh water and medical advice is to be sought.

1、不要拆卸电池。

拆卸电池会发生电池内部短路，会引起起火、爆炸、有害气体或者其它问题。

2、电解液是有害的

万一电解液沾到皮肤、进入眼睛，应立即用清水冲洗以及求助医生。

### 11.4 Prohibition of dumping of cells into fire (不要把电池倾倒入火中)

Never incinerate nor dispose the cells in fire. These may cause explosion of the cells, which is very dangerous and is prohibited.

不要焚毁电池，否则会致电池爆炸，这个很危险，必须禁止。

### 11.5 Prohibition of cells immersion into liquid such as water (禁止浸泡电池)

The cells shall never be soaked with liquids such as water, seawater, drinks such as soft drinks, juices, coffee or others.

请不要把电池浸泡在液体当中，像清水、海水，及非酒精饮料、果汁、咖啡或者其它的饮料。

### 11.6 Battery cells replacement (更换电池)

The battery replacement shall be done only by either cells supplier or device supplier and never be done by the user.

更换电池应由电池生产商或设备供应商完成，用户不要自行更换。

### 11.7 Prohibition of use of damaged cells (禁止使用损坏的电池)

The cells might be damaged during shipping by shock. If any abnormal features of the cells are found such as damages in a plastic envelop of the cell, deformation of the cell package, smelling of an electrolyte, an electrolyte leakage and others, the cells shall never be used any more.

The Cells with a smell of the electrolyte or a leakage shall be placed away from fire to avoid firing or explosion.

电池可能在出货途中碰撞而受损。如果发现电池有异常，例如包装损坏、电池包裹变形，有电解液的味道、发现漏液等等，不要再使用这些电池。

电池如果有电解液的味道或者出现漏液，电池放置应该远离火源避免起火及爆炸。

## 12. Period of Warranty (保质期)

The period of warranty is one year from the date of shipment. HUAYOU guarantees to give a replacement in case of cells with defects proven due to manufacturing process instead of the customer abuse and misuse.

电池的保质期从出货之日算起为一年。如果证明电池的缺陷是在制造过程中形成的而不是由于用户滥用及错误使用造成, 本公司负责退换电池。

## 13. Storing the Batteries (电池的存放)

The batteries should be stored at room temperature, charged to about 30% to 50% of capacity.

We recommend that batteries be charged about once per year to prevent over discharge.

电池应当在室温下存放, 应充到 30%至 50%的电量。如长时间储存, 建议每年充一次电以防止电池过放电。

## 14. Other The Chemical Reaction (其它的化学反应)

Because batteries utilize a chemical reaction, battery performance will deteriorate over time even if stored for a long period of time without being used. In addition, if the various usage conditions such as charge, discharge, ambient temperature, etc. are not maintained within the specified ranges the life expectancy of the battery may be shortened or the device in which the battery is used may be damaged by electrolyte leakage. If the batteries cannot maintain a charge for long periods of time, even when they are charged correctly, this may indicate it is time to change the battery.

由于电池是利用化学反应的原理, 所以随时间的增加电池的性能会降低, 即使是存放很长一段时间而不使用。如果使用条件如充电、放电及周围环境温度等情形不在指定的使用范围内, 会使缩短电池的使用寿命, 或者会产生漏液导致设备损坏。如果电池长周期不能充电, 即使充电方法正确, 这样需要更换电池了。

## 15. Note: (注释)

Any other items which are not covered in this specification shall be agreed by both parties.

本说明书未包括事项应由双方协议确定。