

Op Amps for MEMS Microphone Preamp Circuits

INTRODUCTION

A microphone preamp circuit is used to amplify a microphone's output signal to match the input level of the devices following it in the signal chain. Matching the peaks of the microphone's signal level to the full-scale input voltage of an ADC makes maximum use of the ADC's dynamic range and reduces the noise that subsequent processing may add to the signal.

A single op amp can be easily used in a circuit as a preamp for a MEMS microphone output. The MEMS microphone is a single-ended output device, so a single op amp stage can be used to add gain to the microphone signal or just to buffer the output.

This application note covers some of the key op amp specifications to consider in a preamp design, shows a few basic circuits, and provides a table of Analog Devices, Inc., op amps that may be appropriate for a preamp design. The ADMP504 MEMS microphone is used as an example in this application note to describe different design choices. This is an analog microphone with 65 dB SNR. Designs using different microphones may require adjustment from what is described in this application note, depending on the microphone noise, sensitivity, maximum acoustic input and other specifications. For more information on InvenSense MEMS microphones, see <http://www.invensense.com/mems/microphone/microphone.html>.

OP AMP SPECIFICATIONS

An op amp data sheet has many different specifications and performance graphs, so it can be overwhelming to try to find exactly which of these specs matter for your application. For a microphone preamp design, there are a few specs that matter more than others; these specs are reviewed here.

Noise

An op amp's noise spec is given for both voltage noise and current noise. Typically, you only need to concern yourself with an op amp's voltage noise in a preamp design. The current noise becomes limiting in the design only when high value (that is, noisy) resistors are used. To keep the overall noise of the circuit low, typically resistors with values less than 10 k Ω are used.

The voltage noise of an op amp is specified as a noise density unit of nV/ $\sqrt{\text{Hz}}$. To get the device noise in the circuit's bandwidth of interest, you need to multiply this noise density by the square root of the bandwidth. Note that this simple formula only works for a noise spectrum that is uniform in the frequency range of interest, as shown in Figure 1.

For a 20 kHz bandwidth, this multiplication factor is 141. Using the ADA4075-2 as an example, its noise density of 2.8 nV/√Hz multiplied by 141 gives a noise level of 0.395 μV, or –128 dBV. An op amp's noise density is also typically shown across frequency in a graph in the typical performance characteristics section of the data sheet. This graph is useful to see below what frequency the op amp noise is dominated by 1/f noise. For many op amps, this point is below the low end of the audio band (20 Hz), but it is worth looking at the noise density plot and not just relying on the noise density specification to completely describe the noise performance. Figure 1 shows an example noise density graph from the ADA4075-2 data sheet. Notice in Figure 1 that the 1/f corner is at about 10 Hz, well below the band of interest for MEMS microphone preamp circuits.

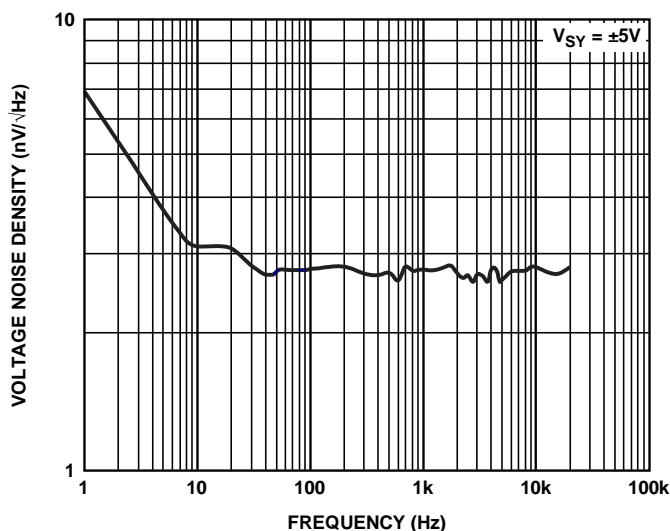

Figure 1. ADA40750-2 Voltage Noise Density

An ADMP504 analog MEMS microphone has a 65 dB SNR (A-weighted) and a –38 dBV sensitivity. This gives it a noise floor of –103 dBV across a 20 kHz bandwidth. This is equivalent to a noise density of about 50 nV/√Hz, which is about the same thermal noise of a 150 kΩ resistor.

It is key for the op amp to be significantly quieter than the microphone so that, with regards to noise, it's as transparent in the preamp circuit as possible. A good rule of thumb is for an op amp's noise to be at least 10 dB quieter than the microphone itself to minimize its contribution to the overall noise. To achieve this with an ADMP504 preamp, you want the op amp to have a maximum noise floor of –113 dBV, or 15.9 nV/√Hz. Most of the op amps in Table 1 are well below this threshold and the ones that are not are still listed because they have other specs that may be more important in a particular design, such as operating current for a low power design. Note that the circuit's total output noise level will be affected by the gain applied and the resistors in the circuit, and not just the op amp. Resistors can usually be chosen to be small enough to have minimal contribution to the overall circuit noise.

Slew Rate

The slew rate of an op amp describes how quickly its output voltage can change (or slew) from one voltage to another. This specification is typically given in units of V/μs. The highest slew rate a preamp circuit will need to support is given by

$$SR = 2 \times \pi \times f_{MAX} \times V_P$$

Here, f_{MAX} is the highest frequency the preamp needs to support (typically 20 kHz for audio) and V_P is the peak voltage level at the output of the op amp. If the peak output voltage is +12 V (8.5 V_{RMS}), then an op amp should have a slew rate of at least 1.5 V/μs.

In practice, most audio signals will not reach the full-scale voltage at higher frequencies, but it is a good idea to design a preamp for that possibility. Slew rate is not a specification for which you typically have to over-design a circuit. You can find an op amp with a slew rate that is fast enough to handle the highest frequency of interest for your design, but do not need to include significant margin above this limit.

THD + N

Talking about total harmonic distortion plus noise (THD + N) in an op amp circuit can quickly become a complicated discussion. Distortion can come from many different sources, including slew rate limiting, output loading, and the op amp's intrinsic distortion characteristics. THD is always specified as a ratio, either as a percentage or as a decibel number. This is the ratio of the amplitude of the harmonic distortion components of the signal to the fundamental input frequency, so a lower number (smaller percentage or more negative dB value) indicates better THD + N performance.

The THD + N specification includes the noise across a specified bandwidth summed with the THD. This is not included in the spec table of all op amp data sheets, but even when it is not, a graph of THD (or THD + N) vs. frequency is often included. An example of this from the ADA4075-2 data sheet is shown in Figure 2.

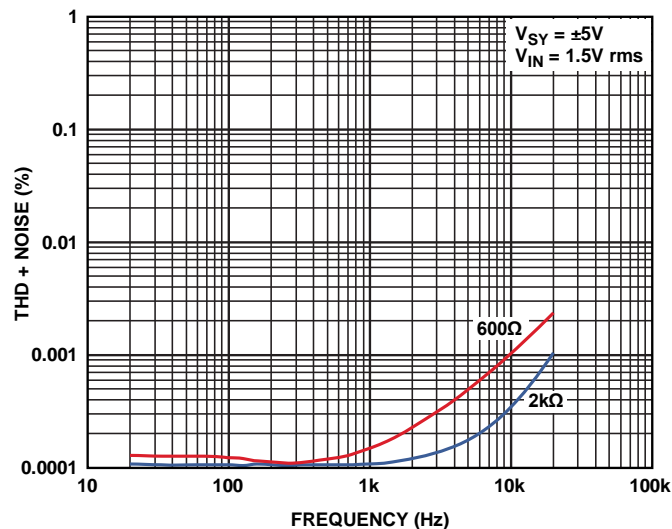

Figure 2. ADA4075-2 THD + Noise vs. Frequency

Supply Voltage

An op amp supply voltage is usually given as a range, such as 3 V to 30 V, which indicates the minimum and maximum differences between the V+ and V- supply pins. This supply could be provided to the op amp as either a single voltage, with V- connected to ground, or a bipolar supply with V+ and V- set to positive and negative voltages of the same value (for example, ± 15 V).

The supply voltage needs to be selected so that the op amp's output does not clip given the supply rails. Some op amps are specified for rail-to-rail operation, which means that the input or output voltages (depending on what is being specified) can go all the way to the rail voltages without clipping. If the op amp is not rail-to-rail, then the maximum input and output voltages will be specified in the data sheet; note that the maximum positive and negative voltages will not always be of equal value.

The signal's peak output voltage obviously is directly related to the amount of gain that the preamp circuit provides. The peak output voltage of the ADMP504 is $0.25 V_{rms}$. An ADMP504 connected to a preamp with a gain of 20 dB ($10\times$ gain) will have a peak output voltage of $2.5 V_{rms}$, which is $7.0 V_{p-p}$. Thus, this circuit needs a supply voltage of at least 7.0 V, or ± 3.5 , when using a rail-to-rail output op amp. The supply voltage will need to be higher if the op amp's outputs are not rail-to-rail.

An analog MEMS microphone operates from a 1.5 V to 3.3 V supply. The lowest supply that some of the op amps listed in Table 1 support is 2.7 V, so in a low power single-supply circuit, the microphone's V_{DD} supply will need to be set between 2.7 and 3.3 V.

Gain Bandwidth Product

As its name indicates, the gain bandwidth product (GBP) is the product of the amplifier's bandwidth (using the low-pass -3 dB corner) and gain applied to the input signal. Most preamp designs for MEMS microphones do not need to add more than 40 dB of gain, which is a factor of 100. Designing a preamp to have a bandwidth of at least 50 kHz provides some margin to ensure that the higher audio frequencies are not affected by the op amp's bandwidth limit. An op amp with a 6.5 MHz GBP, like the ADA4075-2, in a circuit with 40 dB of gain will have a pass band up to 65 kHz before the signal begins to roll off.

This specification is plotted in the typical performance characteristics section of the data sheet as gain vs. frequency. This graph from the ADA4075-2 data sheet (see Figure 3) shows that op amp's open-loop gain vs. frequency.

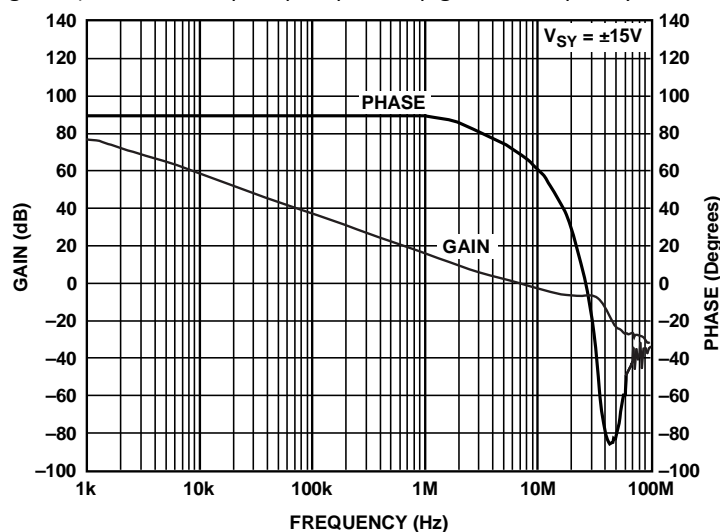

Figure 3. ADA4075-2 Open-Loop Gain and Phase vs. Frequency

Other Specifications

There are some other specifications to consider, depending on how specifically the circuit will be used. For example, if the preamp needs to be able to drive a low impedance load, like headphones, then you will want to select an op amp with high drive capability.

An op amp's supply current is typically specified per amplifier with no load current. Low-power circuit designs are best done with op amps that have a low supply current. The op amp noise and supply current are often inversely related, so a tradeoff may need to be made for audio performance vs. power.

Finally, there are some other specifications with which you do not need to be concerned. Offset voltage is often presented as a key op amp spec, but is not critical for preamp applications that are AC-coupled.

CIRCUITS

Basic preamp circuits come in two configurations: inverting and noninverting. The uses and advantages of each are described in this section.

These circuits do not show power supplies or bypass capacitors. While important for good circuit performance, showing these is not critical for describing the preamp function. More information about decoupling capacitors and proper grounding for your design can be found in most op amp data sheets and Analog Devices' [AN-202](#) Application Note, *An IC Amplifier User's Guide to Decoupling, Grounding, and Making Things Go Right for a Change*. You can also find many other more specialized audio circuits in many op amp data sheets.

Noninverting

The output of a noninverting preamp circuit has the same polarity as its input. This circuit is good to use in applications where it is critical that the signal polarity is not inverted. The gain of a noninverting op amp circuit is $G = (R1 + R2)/R1$, for a configuration as shown in Figure 4.

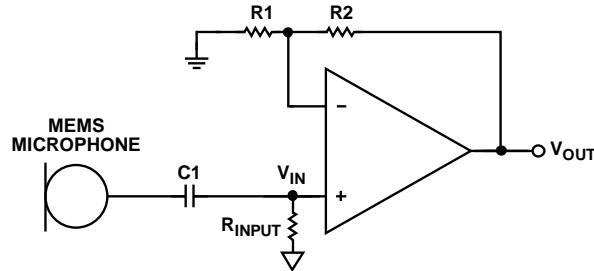

Figure 4. Noninverting Preamp Circuit

This configuration can have a high input impedance when R_{INPUT} is chosen to be appropriately large. A 47 kΩ input impedance is often used for audio applications, but lower values may be used. C1 is a DC-blocking capacitor that is used because the MEMS microphone’s output is biased at 0.8 V. Capacitor C1 and resistor R_{BIAS} form a high pass filter, so the filter’s corner frequency must be balanced against the circuit’s input impedance.

Common-mode rejection is a spec that is of more concern for noninverting circuits than for inverting topologies. In a non-inverting circuit, the common-mode voltage can cause distortion in the output signal. Op amp data sheets typically specify common-mode rejection ration (CMRR) vs. frequency, so you can look at this to determine the performance of a specific device in the audio frequency band. This is not an issue for inverting circuits because there is no dynamic common-mode voltage; both inputs are held at ground or virtual ground.

Inverting

Figure 5 shows an inverting op amp circuit. The polarity at the output of this circuit is inverted from the input and the gain is $G = -R2/R1$.

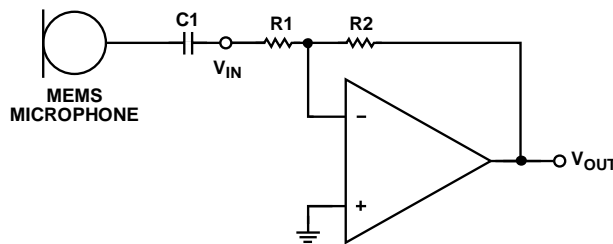

Figure 5. Inverting Preamp Circuit

The input impedance of an inverting circuit is equal to R1. This resistor forms a voltage divider with the MEMS microphone’s output, so the resistor’s value needs to be chosen so that it is high enough not to load the microphone output, but not so high that it adds unnecessary noise to the circuit. The analog MEMS microphones typically have an output impedance of 200 Ω. If R1 is chosen to be 2.0 kΩ, the resulting voltage divider will reduce the level of the signal output from the microphone by 9%

$$V_{OUT} = (2.0 \text{ k}\Omega + 200 \text{ }\Omega) / 2.0 \text{ k}\Omega \times V_{IN} = 0.91 \times V_{IN}$$

DC-blocking capacitor C1 and R1 will form a high-pass filter, so C1 should be selected to be large enough so that this filter does not interfere with the microphone’s input signal. The ADMP504 has a low frequency corner at 100 Hz. If R1 is again chosen to be 2.0 kΩ, then a capacitor of 2.2 μF results in a high-pass filter –3 dB frequency of 40 Hz, which is sufficiently below the microphone’s corner frequency.

A good rule of thumb is to select the cutoff frequency at least one octave below that of the microphone, unless a specific high-pass characteristic is sought.

Voltage Follower

A noninverting amplifier can also be implemented as a voltage follower if no divider circuit is used in the feedback loop. This circuit is useful for buffering the microphone’s output when it is not able to drive longer traces or cables directly, and may not need additional gain added to the signal. The voltage follower’s input impedance is set by R_{INPUT} .

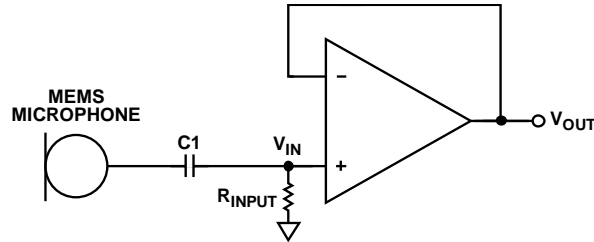

Figure 6. Voltage Follower

A voltage follower can also be used as a buffer in front of an inverting stage. This configuration may be desired so that lower value resistors can be used in the inverting circuit. Without the buffer, the input impedance of the inverting stage may need to be lower than is desired to achieve the target noise performance. With this buffer in place and the first op amp’s low output impedance (compared to the MEMS microphone), the values of resistors R1 and R2 can be made very small so that they do not contribute extra noise to the circuit.

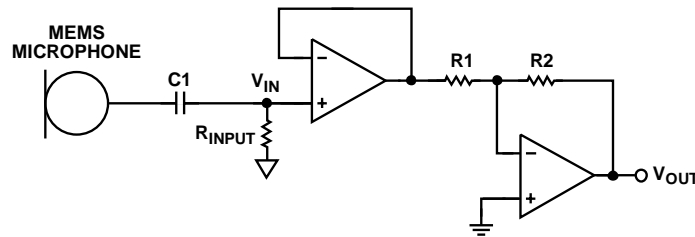

Figure 7. Voltage Follower Buffer with Inverting Amplifier

Differential Output

A MEMS microphone’s single-ended output can be converted into a differential signal with two op amps in a simple series combination of two inverting circuit stages (see Figure 8). The outputs from each stage, which are inverted relative to each other, then serve as the differential pair. In the circuit shown in Figure 8, the signal amplification happens in the first stage and is set by R1 and R2. Resistors R3 and R4 should be of equal value to provide unity gain in the second stage. For best performance, 1% resistors (or better) should be used to minimize the error between the two stages.

One downside of this configuration is that one output has only one amplifier’s contribution to the noise and distortion, while the second output has two amplifiers worth of noise and distortion. A second small issue is that there is a nonzero time delay through each amplifier, so the two legs of the differential output are not perfectly aligned. However, this will likely have a very small effect on the differential signal performance.

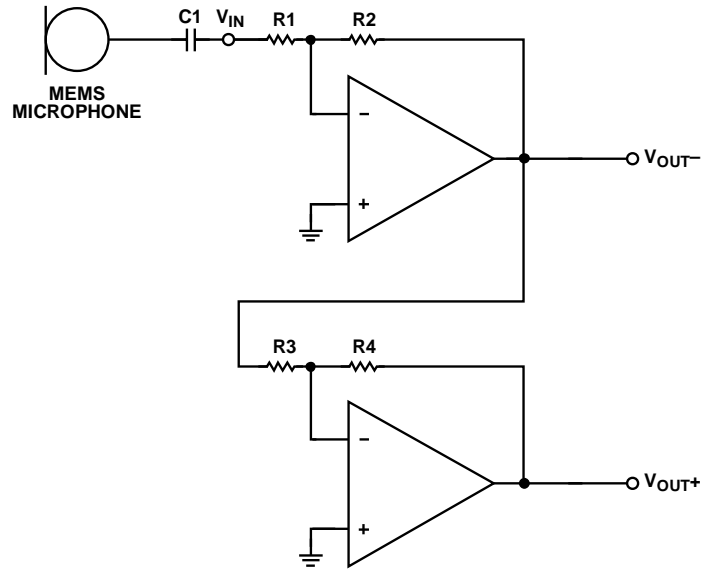

Figure 8. Differential Output Circuit

The voltage follower and inverting amplifier circuit shown in Figure 7 can also be used to create a differential signal with a gain of 1. The noninverted output would be taken from the output of the voltage follower amplifier and the inverted output would be taken from the output of the inverting amp. In this configuration, the values of R1 and R2 should be equal to achieve unity gain.

A difference amp, like the AD8273, could also be used to create this single-ended-to-differential circuit and may have better performance with regards to the issues mentioned above.

Figure 9 shows the AD8273 configured as a single-ended-to-differential amplifier. Each amplifier is configured for $G = 2$, thus the differential gain is $4\times$.

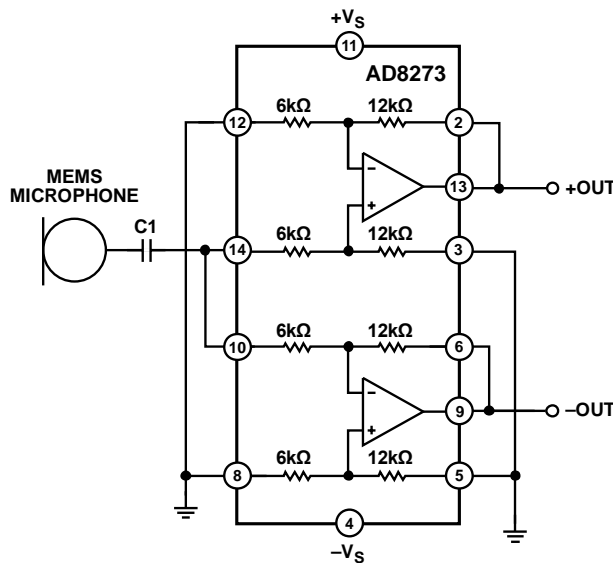

Figure 9. AD8273 Single-Ended-to-Differential Configuration, $G = 4$

OP AMP SELECTION

There is a large selection of different op amps from different vendors that are suitable for microphone preamp applications. Table 1 shows the specs for some of these parts from Analog Devices and is sorted by voltage noise.

TABLE 1. AUDIO OP AMPS

Op Amp	Channels	Noise (nV/√Hz)	GBP (MHz)	Slew Rate (V/μs)	THD+N (dB, 20 kHz)	Supply (V)	Current/Amp (mA)	Package(s)
AD797	1	0.9	8	20	-120	10 to 36	10.5	PDIP, SOIC
ADA4898	1/2	0.9	65	55	-116	10 to 32	7.9	SOIC
ADA4897	1/2	1	230	120		3 to 10	3	SOIC, SOT-23
AD8597/AD8599	1/2	1.07	10	14	-120	10 to 36	4.8	SOIC, LFCSP
ADA4841	1/2	2.1	80	12		2.7 to 12	1.1	SOIC, SOT-23, MSOP, LFCSP
AD8655/AD8656	1/2	2.7	28	11	-102	2.7 to 5.5	11	MSOP, SOIC
ADA4075-2	2	2.8	6.5	12	-114	9 to 36	1.8	SOIC, LFCSP
OP37	1	3	12	17		8 to 44	5.67	SOIC, DIP
ADA4084-2	2	3.9	13.9	2.6	-83	3 to 30	0.565	MSOP, SOIC, LFCSP
AD8651/AD8652	1/2	4.5	50	41	-104	2.7 to 5.5	8	MSOP, SOIC
ADA4528	1	5.3	4	0.5	-80	2.2 to 5.5	1.4	MSOP, LFCSP
ADA4627	1	6.1	19	40	-127	10 to 30	7	SOIC, LFCSP
AD8605/AD8606/	1/2/4	6.5	10	5	-86	2.7 to 6	1.2	SOT-23, WLCSP, SOIC, TSSOP
AD8608	2/4	8	24	11	-80	2.7 to 5.5	2	SOIC, MSOP, TSSOP
AD8646/AD8648	1/2/4	8	1.3	0.7		5 to 36	0.5	MSOP, SOIC
OP1177	2/4	11	0.56	10	-82	5 to 30	0.215	SOIC, MSOP
AD8622/AD8624	1	22	5	2.7		1.8 to 6	0.5	SOT-23, SC70
AD8515	1/2/4	40	1	0.75		2.7 to 5.5	0.045	SOT-23, SC70, SOIC

Compliance Declaration Disclaimer:

InvenSense believes this compliance information to be correct but cannot guarantee accuracy or completeness. Conformity documents for the above component constitutes are on file. InvenSense subcontracts manufacturing and the information contained herein is based on data received from vendors and suppliers, which has not been validated by InvenSense.

Environmental Declaration Disclaimer:

InvenSense believes this environmental information to be correct but cannot guarantee accuracy or completeness. Conformity documents for the above component constitutes are on file. InvenSense subcontracts manufacturing and the information contained herein is based on data received from vendors and suppliers, which has not been validated by InvenSense.

This information furnished by InvenSense is believed to be accurate and reliable. However, no responsibility is assumed by InvenSense for its use, or for any infringements of patents or other rights of third parties that may result from its use. Specifications are subject to change without notice. InvenSense reserves the right to make changes to this product, including its circuits and software, in order to improve its design and/or performance, without prior notice. InvenSense makes no warranties, neither expressed nor implied, regarding the information and specifications contained in this document. InvenSense assumes no responsibility for any claims or damages arising from information contained in this document, or from the use of products and services detailed therein. This includes, but is not limited to, claims or damages based on the infringement of patents, copyrights, mask work and/or other intellectual property rights.

Certain intellectual property owned by InvenSense and described in this document is patent protected. No license is granted by implication or otherwise under any patent or patent rights of InvenSense. This publication supersedes and replaces all information previously supplied. Trademarks that are registered trademarks are the property of their respective companies. InvenSense sensors should not be used or sold in the development, storage, production or utilization of any conventional or mass-destructive weapons or for any other weapons or life threatening applications, as well as in any other life critical applications such as medical equipment, transportation, aerospace and nuclear instruments, undersea equipment, power plant equipment, disaster prevention and crime prevention equipment.

©2013 InvenSense, Inc. All rights reserved. InvenSense, MotionTracking, MotionProcessing, MotionProcessor, MotionFusion, MotionApps, DMP, and the InvenSense logo are trademarks of InvenSense, Inc. Other company and product names may be trademarks of the respective companies with which they are associated.



©2013 InvenSense, Inc. All rights reserved.