

C series | General Applications

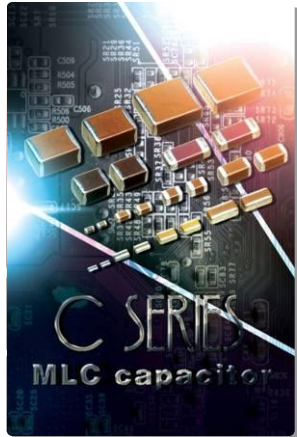

Contents

- Purpose / Objectives
- TDK MLCC Lineup
- Background
- Cap Range
- Features
- Applications
- Design Tools/Resources
- Part Number Description
- Summary

C series I General Applications

Purpose

- To provide a general overview of TDK's "C Series" Multilayer Ceramic Capacitors for use in General Applications

Objectives

- Define TDK's C Series capacitors for General Applications
- Discuss the primary functions of TDK's C Series Capacitors
- Highlight the features and applications of TDK's C Series Capacitors for General Applications

SERIES		FEATURES	OFFERING
C 	General Applications	<ul style="list-style-type: none"> Wide range of case size and superior dimension precision Available in EIA class 1 and 2 dielectrics up to 50V 	<ul style="list-style-type: none"> 01005 ~ 2220 / C0G, SL, X5R, X6S, X7R, X7S, Y5V 4V ~ 50V / up to 100 μF
	Mid Voltage	<ul style="list-style-type: none"> Unique design allows for higher voltage in smaller case size Available in 100V, 250V, 450V, and 630V 	<ul style="list-style-type: none"> 0402 ~ 2220 / C0G, X6S, X7R, X7S, X7T 100V ~ 630V / up to 15 μF
	High Voltage	<ul style="list-style-type: none"> Advance design provides improved withstanding voltage Available rating up to 3000V 	<ul style="list-style-type: none"> 1808 ~ 1812 / C0G, X7R, X8S 1000V ~ 3000V / up to 10 nF
	High Temperature	<ul style="list-style-type: none"> Stable temperature characteristics up to 150°C Highly precise temperature performance (7.5%) up to 125° C 	<ul style="list-style-type: none"> 0402 ~ 1210 / X8R 16V ~ 100V / up to 10 μF
	High Q	<ul style="list-style-type: none"> Design with higher Q factor than standard capacitors Excellent attenuation and high self resonance frequency (SRF) 	<ul style="list-style-type: none"> 0201 / C0G 25V / up to 20 pF
	Flip Type	<ul style="list-style-type: none"> Flipped geometry provides lower inductance than standard capacitor Special design allows for adequate high frequency current to IC 	<ul style="list-style-type: none"> 0204 ~ 0612 / X5R, X6S, X7R, X7S 4V ~ 50V / up to 10 μF
	Open Mode	<ul style="list-style-type: none"> Unique design allows for increase resistance to mechanical bending Improved performance in vibration and electrical stresses 	<ul style="list-style-type: none"> 0805 ~ 2220 / X7R, X8R 16V ~ 630V / up to 22 μF
	Soft Termination	<ul style="list-style-type: none"> Improved bending resistance and temperature cycle performance Termination technology available for most case sizes including arrays 	<ul style="list-style-type: none"> 0805 ~ 3025 / X7R, X7S, X7T 16V ~ 630V / up to 100 μF
	Conductive Epoxy	<ul style="list-style-type: none"> AgPdCu termination for conductive glue mounting Improved mechanical/thermal strength when used with conductive glue 	<ul style="list-style-type: none"> 0402 ~ 1210 / C0G, X7R, X8R 25V ~ 100V / up to 10 μF
	CER	Controlled ESR	<ul style="list-style-type: none"> Unique design allows for specified "controlled" ESR Same no-hassle mounting method as standard 2-terminal components ESR is controlled without affecting the ESL
CEU	Serial Design	<ul style="list-style-type: none"> 2 series-connected capacitors in one body Improved bending resistance and temperature cycle performance Ultra high reliability design for automotive battery line applications 	<ul style="list-style-type: none"> 0603 ~ 0805 / X7R 50V / up to 100 nF
CGA	Automotive Applications	<ul style="list-style-type: none"> Qualified to CDF AEC Q-200 automotive testing standard Manufactured using matured process for guaranteed performance Available in C0G, X7R and X8R temperature characteristics 	<ul style="list-style-type: none"> 0402 ~ 2220 / C0G, X5R, X7R, X7S, X7T, X8R 6.3V ~ 630V / up to 47 μF
CGJ	High Reliability Applications	<ul style="list-style-type: none"> Extensive testing to ensure higher reliability and longer life Reliability tests based on MIL-STD requirements Guaranteed TC Bias and Hot IR performance 	<ul style="list-style-type: none"> 0402 ~ 1206 / C0G, X7R 6.3V ~ 50V / up to 10 μF
CKC	2-in-1 Array 4-in-1 Array	<ul style="list-style-type: none"> Allows for reduction of PCB space and mounting time Unique electrode design reduces crosstalk Also available in soft termination for higher reliability performance 	<ul style="list-style-type: none"> CKCN27 ~ CKCA43 / C0G, X5R, X7R 6.3V ~ 50V / up to 2.2 μF
CKD	Feed Through	<ul style="list-style-type: none"> Optimized for noise bypass with signal and power source circuits Can be used for meeting EMC requirements Ideal for use at higher frequencies due to low parasitic inductance 	<ul style="list-style-type: none"> 0402 ~ 1206 / up to 125°C temperature range 6.3V ~ 50V / up to 22 μF
CKG	Mega Cap	<ul style="list-style-type: none"> Advance design for twice the capacitance on single footprint Improved vibration and thermal/mechanical stress performance Lower ESR and ESL than ALU and TA capacitor 	<ul style="list-style-type: none"> CKGxxK ~ CKGxxN / X5R, X7R, X7S, X7T 16V ~ 630V / up to 100 μF
CLL	Ultra Low Inductance	<ul style="list-style-type: none"> Unique internal structure allows cancelation of magnetic fields to reduce equivalent series inductance Eight sided terminal electrode design in one capacitor 	<ul style="list-style-type: none"> 0603 ~ 0805 / X7R, X7S 4V ~ 10V / up to 4.7 μF

C series I General Applications - Background -

Basic Design Construction of a Multi-Layer Ceramic Capacitor

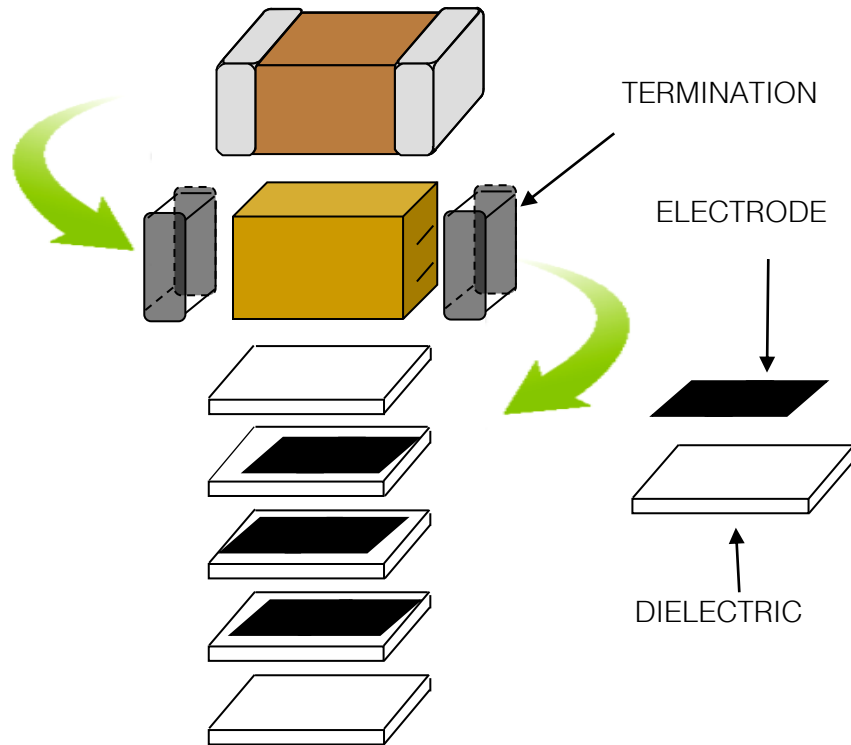

No.	Name	Material	
		Class I	Class II, III
		BME	BME
1	Dielectric	CaZrO ₃	BaTiO ₃
2	Inner Electrode	Ni	Ni
3	Terminal Electrode	Cu	Cu
4		Ni	
5		Sn	

C series I General Applications - Traditional Functions -

Arc Suppression

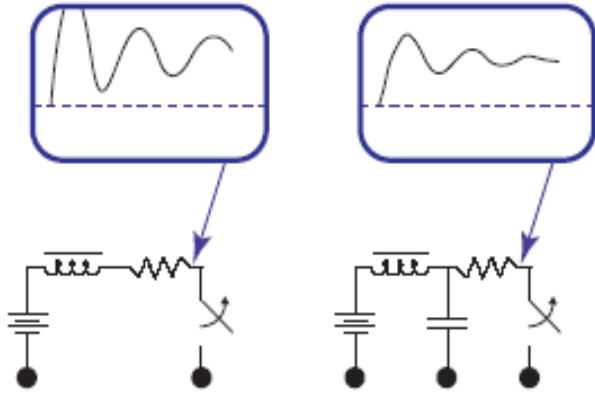

Reduces voltage fluctuations caused by electro-mechanical switches.

Bypassing/Smoothing

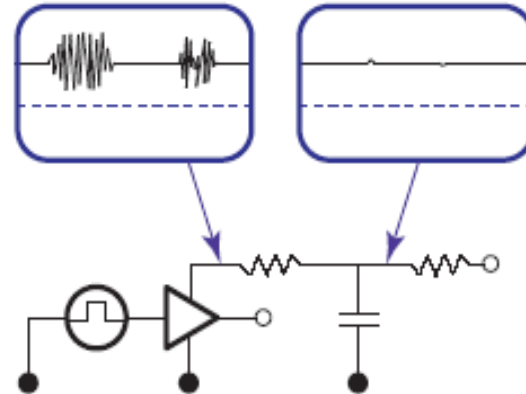

"Absorbs" DC voltage spikes.

Transient Suppression

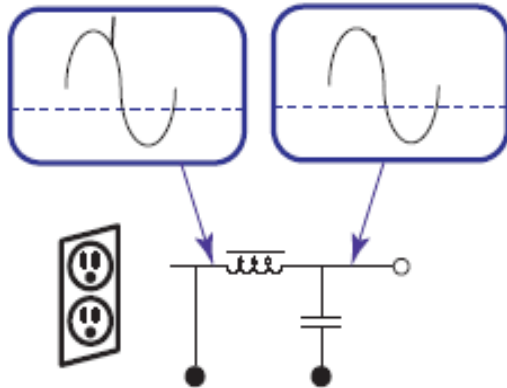

Removes large spikes such as lightning to protect the circuit.

Decoupling

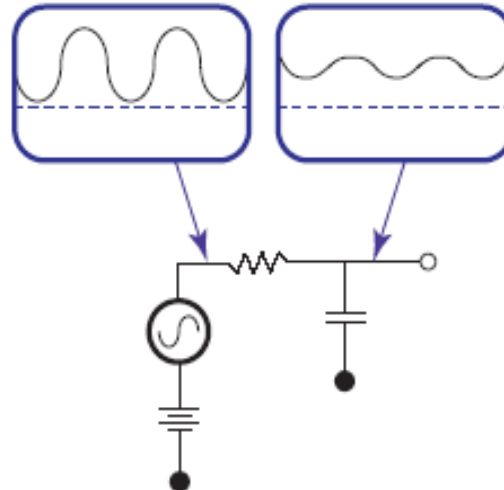

Reduces AC ripple voltage.

C series I General Applications - Traditional Functions -

Filtering

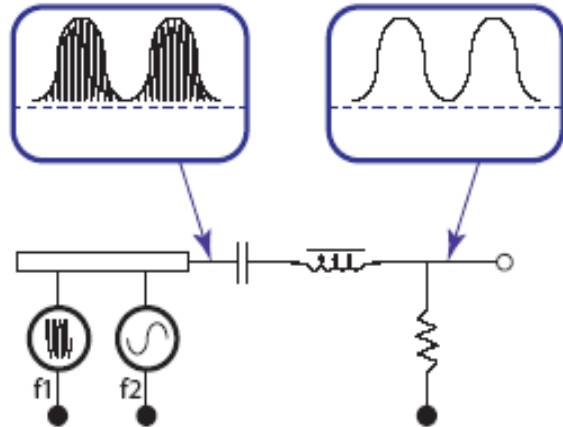

Removes unwanted frequency signals. In this example, f1 is removed.

Blocking

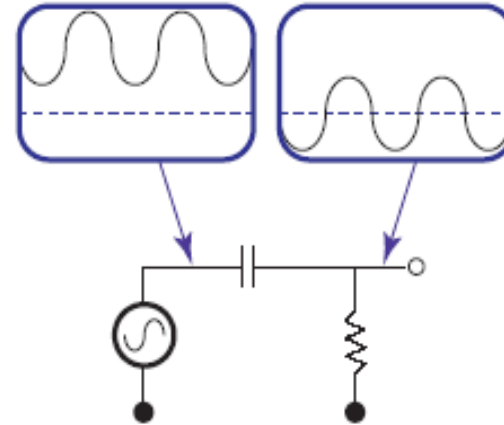

Removes DC portion of signal.

Shaping

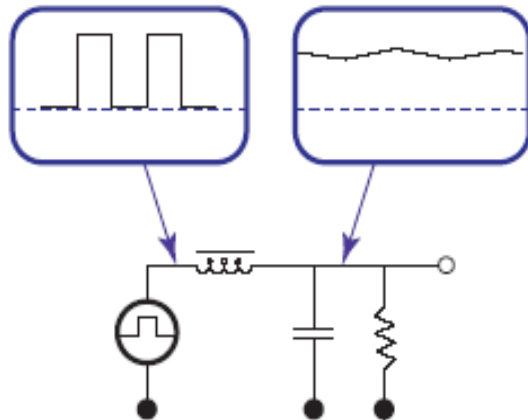

Changes the shape of a signal.

Timing

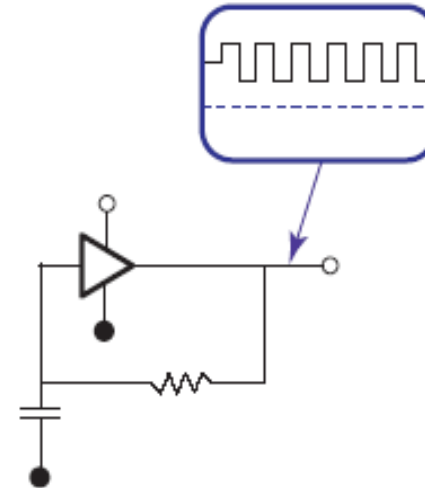

Helps determine the frequency of a signal.

C series I General Applications - Cap Range -

Cap Range:

- ❖ Wide range of case size and superior dimension precision
- ❖ Available in EIA class 1 and 2 dielectrics up to 50V
- ❖ 01005 ~ 2220 / C0G, X5R, X6S, X7R, X7S, Y5V
- ❖ 4V ~ 50V / up to 100uF

Capacitance

$$C = \epsilon_0 \epsilon_r \frac{S}{d} N$$

C : Capacitance
 ϵ_0 : Permittivity in a vacuum
 ϵ_r : Relative permittivity of a dielectric
S : Electrode area
d : Dimensions of the dielectric layer
N : Number of layers

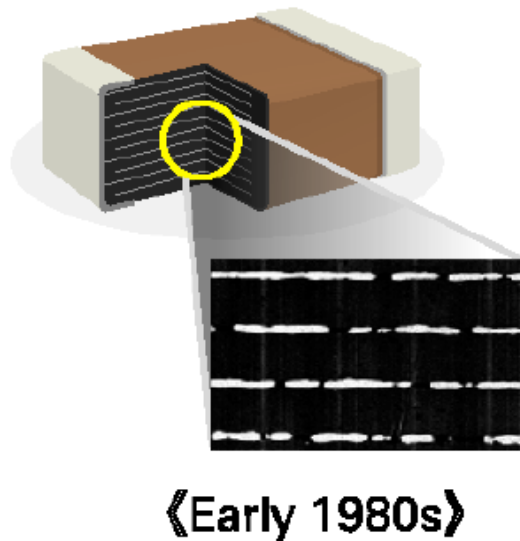

《Early 1980s》



Capacitance has been increased from 0.1 μ F to 100 μ F.

Capacitance
1000 times higher!

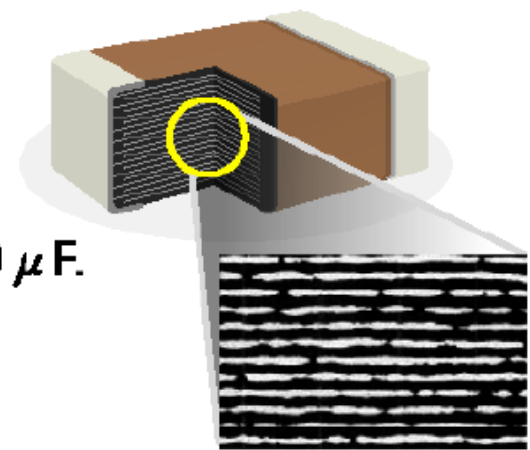

《Today》

C series I General Applications - Features -

Features:

- ❖ TDK's proprietary internal electrode structure
- ❖ Wide capacitance range up to 100 μ F
- ❖ Available voltage rating of 4V to 50V
- ❖ Superior mechanical strength and reliability
- ❖ Low ESR / ESL characteristic
- ❖ Easy mounting due to no polarity

Performance Comparison

	Aluminum Electrolytic Capacitor	Tantalum Electrolytic Capacitor	Polymer Al/Ta Capacitor	MLCC
Cap Density (C/V)	☹️	☹️	☹️	😊
Freq. Characteristics	☹️	☹️	☹️	😊
ESL, ESR	☹️	☹️	☹️	😊
DC-Bias Characteristics	☹️	😊	😊	☹️
Leakage Current	☹️	☹️	☹️	😊
Polarity	☹️	☹️	☹️	😊
Breakdown Voltage	☹️	☹️	☹️	😊
Endurance (Life)	☹️	☹️	☹️	😊

Polymer Al/ Ta Capacitor



Aluminum Electrolytic Capacitor

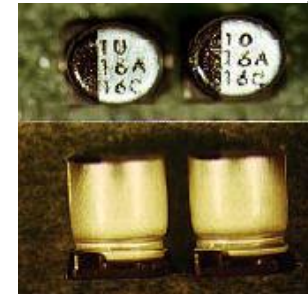

Tantalum Electrolytic Capacitor



Multilayer Ceramic Capacitor

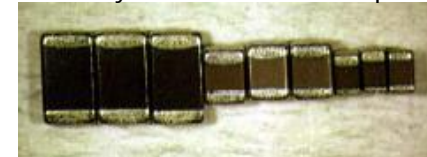

C series I General Applications - Applications -

Applications:

- ❖ General electronic equipment
- ❖ Mobile communication equipment
- ❖ Power supply circuit
- ❖ Office automation equipment
- ❖ TV/LED displays
- ❖ Servers/PCs/Notebooks/Tablets
- ❖ Test and measurement equipment
- ❖ Hybrid ICs, etc.
- ❖ Decoupling / Smoothing
- ❖ Coupling
- ❖ Charge pump



Advantages:

- ❖ Noise suppression
- ❖ Space saving
- ❖ Superior reliability

Step Down DC/DC (Replacement example)

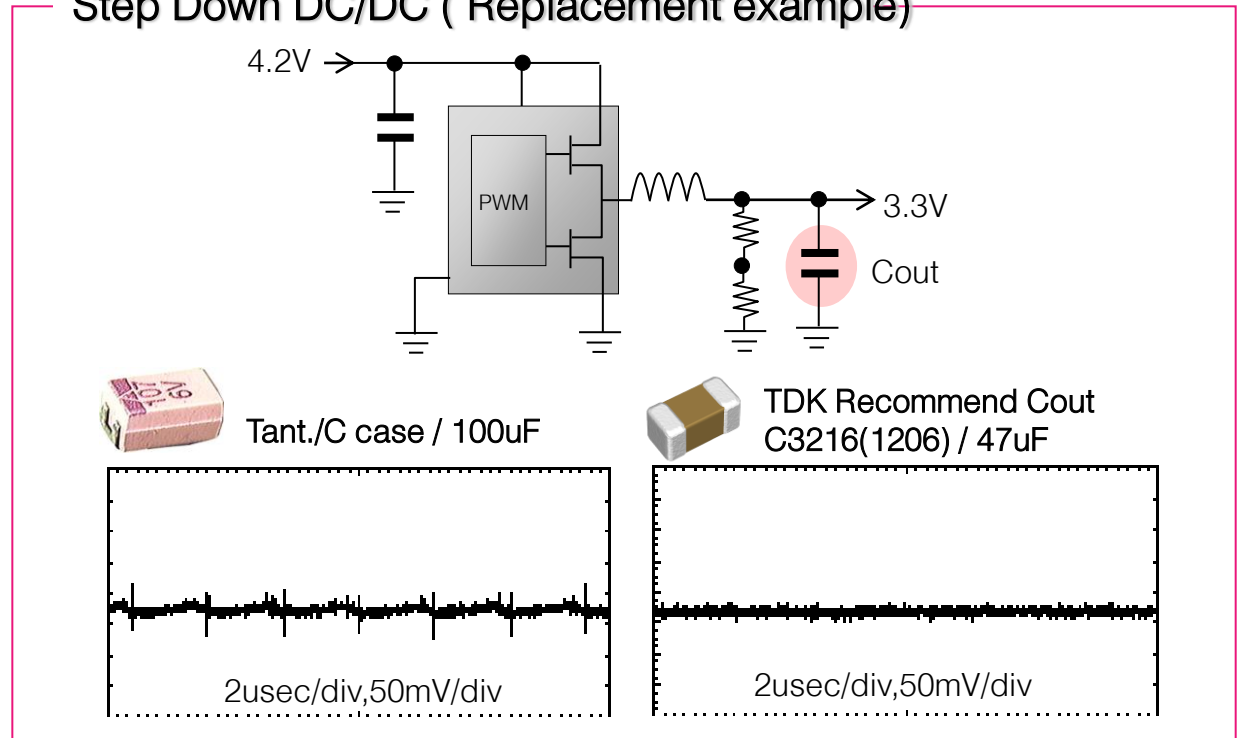

TVCL – TDK Virtual Component Library

<http://www.tdk.com/tvcl.php>

CCV – Components Characteristics Viewer

<http://www.tdk.co.jp/ccv/index.asp>

SEAT – Selection Assistant of TDK Components

<http://www.tdk.com/seat.php>

MLCC Sample Kits

<http://www.mouser.com/Search/Refine.aspx?Ne=254016&N=1323038+4232846+4294963871>

C series I General Applications - Part Number Description -

(1) (2) (3) (4) (5)
C3225 X7S 1H 106 K

(1) Series/Dimension Code

Series	Metric	EIA	L (mm)	W (mm)	T (mm) Nominal
C – General Applications	0402	01005	0.40	0.20	0.20
	0603	0201	0.60	0.30	0.30
	1005	0402	1.00	0.50	0.50
	1608	0603	1.60	0.80	0.80
	2012	0805	2.00	1.20	1.25
	3216	1206	3.20 x 1.60		1.60
	3225	1210	3.20 x 2.50		2.50
	4532	1812	4.50 x 3.20		3.20
	5750	2220	5.70 x 5.00		2.80

(2) Temperature Characteristics

Temperature Characteristics	Temperature Range	Capacitance Change
C0G	-55 ~ 125°C	0 30 ppm/°C
SL	-25 ~ 85°C	350/-1000 ppm/°C
X5R	-55 ~ 85°C	15%
X6S	-55 ~ 105°C	22%
X7R	-55 ~ 125°C	15%
X7S	-55 ~ 125°C	22%
Y5V	-30 ~ 85°C	+22,-82%

(3) Rated Voltage Code (Vdc)

Symbol	Rated Voltage (V _{DC})
0G	4
0J	6.3
1A	10
1C	16
1E	25
1V	35
1H	50

(4) Nominal Capacitance (pF)

Symbol	Cap Value (pF)	Cap Value (nF)	Cap Value (µF)
101	100 pF	0.1 nF	0.0001 µF
102	1,000pF	1 nF	0.001 µF
105	1,000,000 pF	1,000 nF	1 µF
106	10,000,000 pF	10,000 nF	10 µF

The capacitance is expressed in three digit codes and in units of pico Farads (pF). The first and second digits identify the first and second significant figures of the capacitance. The third digit identifies the multiplier. R designates a decimal point.

(5) Capacitance Tolerance Code

Symbol	Capacitance Tolerance
W	0.05pF
B	0.10pF
E	0.20pF
C	0.25pF
D	0.50pF
F	1%
G	2%
J	5%
K	10%
M	20%
Z	+80/-20%

C series I General Applications - Summary -

Summary:

- ❖ TDK's C Series MLCCs for general applications are used to serve the traditional requirements for capacitors in electronic circuits
- ❖ TDK's C Series MLCCs for general applications offer solutions for current industry trends to downsize and replace less reliable capacitor technologies
- ❖ TDK has design tools to help support optimal MLCC component selection



Why TDK:

- ❖ World Class Supplier
- ❖ ppb Quality
- ❖ Local Factory Support
- ❖ Zero restrictive or banned materials