



NIDEC CORPORATION

Robot Cleaner Motor Product Introduction

DTC (Dalian Technical & Support Center)

2020/09/18

Robot Cleaner – Blower Unit

Blower (Standard product)	20N183L010 A	20N704R310	20N704R500	20N704S310	22N709Q140
					
Appearance feature	With fixing device	With fixing device	Without fixing device	Without fixing device	Without fixing device
Voltage[V]	12	14.4	14.4	14.4	14.4
Input power[W]	20	31.7	31.7	23	64.8
Rated speed [rpm]	15000	17200	17200	15100	22500
Rated current [A]	1.7	2.2	2.2	1.6	4.5
Maximum static pressure [Pa]	1800	2600	2600	3000	4000
Maximum air volume [m ³ /min]	0.63	0.78	0.78	0.63	0.99
Noise[dB (A)]	67	70	70	68	75

Robot Cleaner – Blower Unit



20N183L010 A

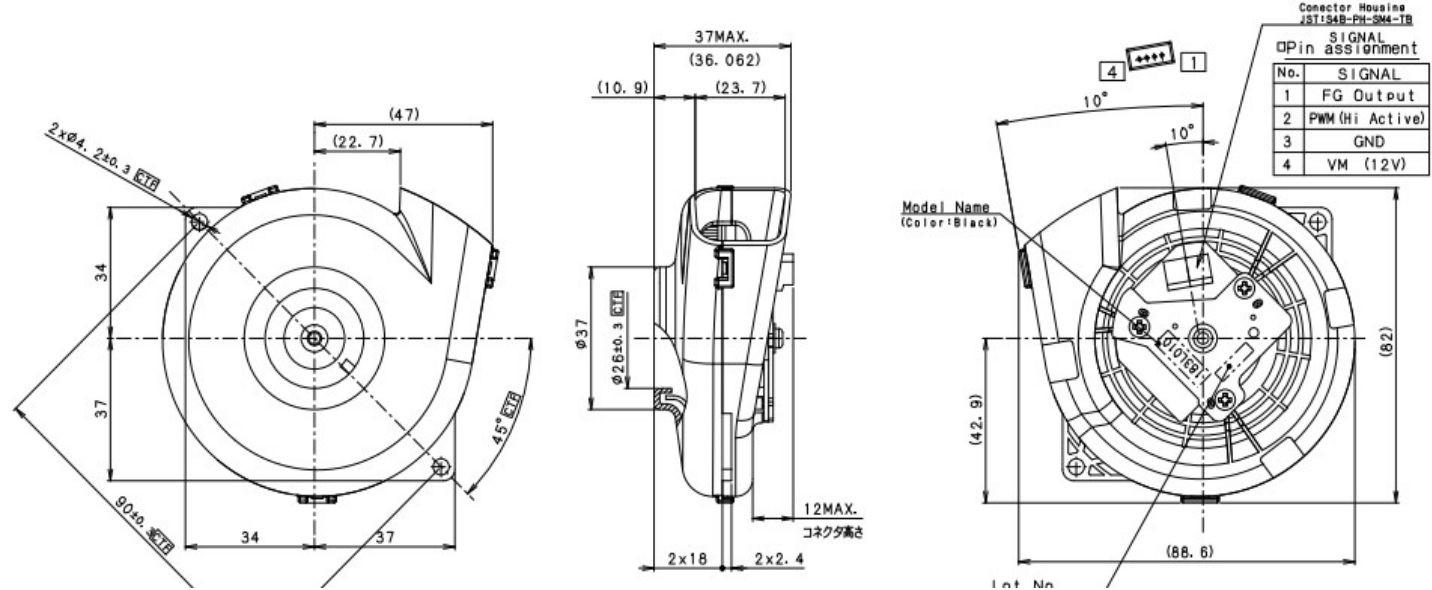
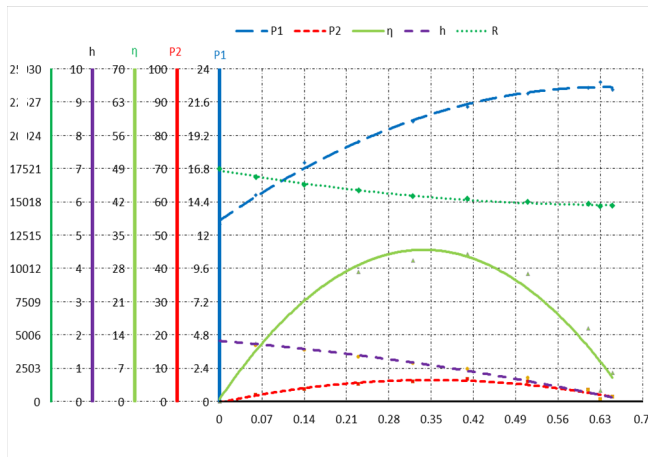

P1: Input power P2: Output Power η: Effectiveness R: Rotating speed h: Static pressure

Item	Rated voltage (V)	Rated speed (rpm)	Rated current (A)	Rated power (W)	Maximum static pressure (kPa)	Maximum air volume (m ³ /min)	SPL noise (dB (A))
Parameter	12	15000	1.7	20	1.8	0.63	67

Robot Cleaner – Blower Unit



20N704R310
(20N704R500)

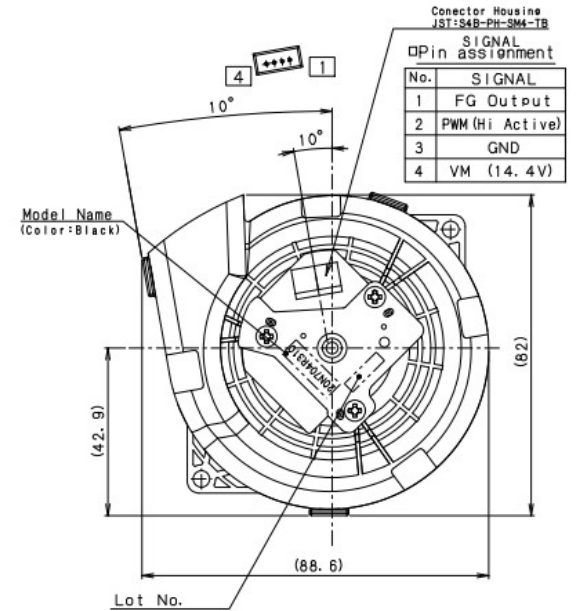
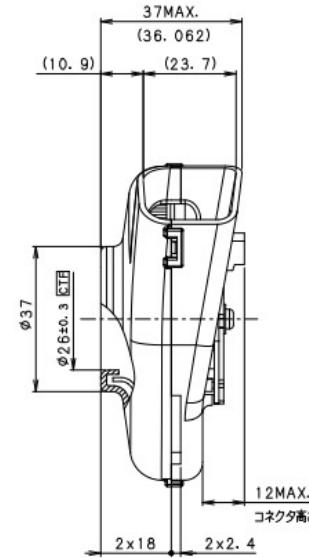
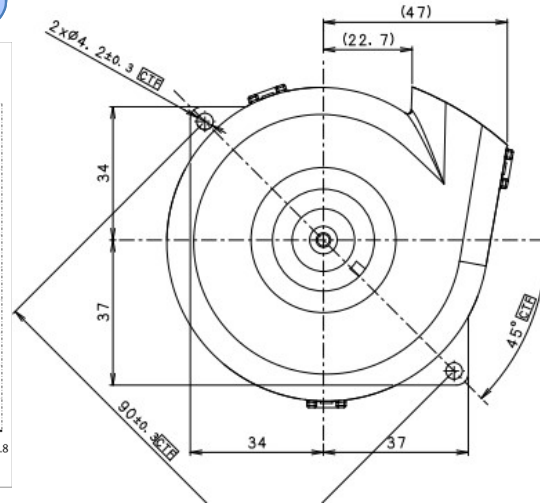
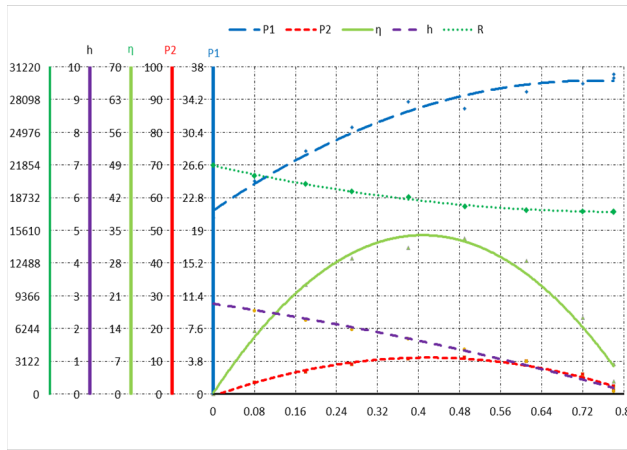

P1: Input power **P2:** Output Power **η:** Effectiveness **R:** Rotating speed **h:** Static pressure

Item	Rated voltage (V)	Rated speed (rpm)	Rated current (A)	Rated power (W)	Maximum static pressure (kPa)	Maximum air volume (m ³ /min)	SPL noise (dB (A))
Parameter	14.4	17200	2.2	32	2.6	0.78	70

Robot Cleaner – Blower Unit



20N704S310

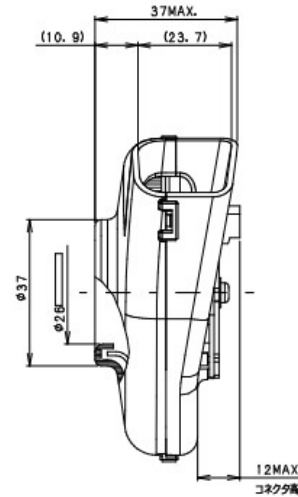
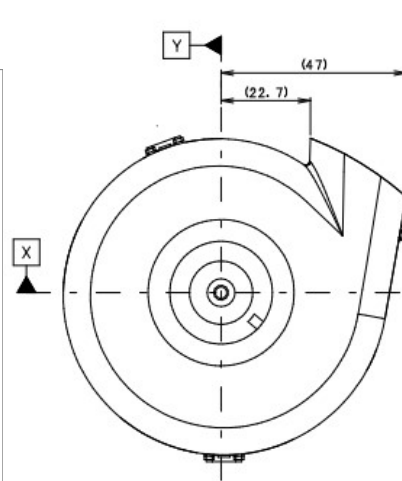
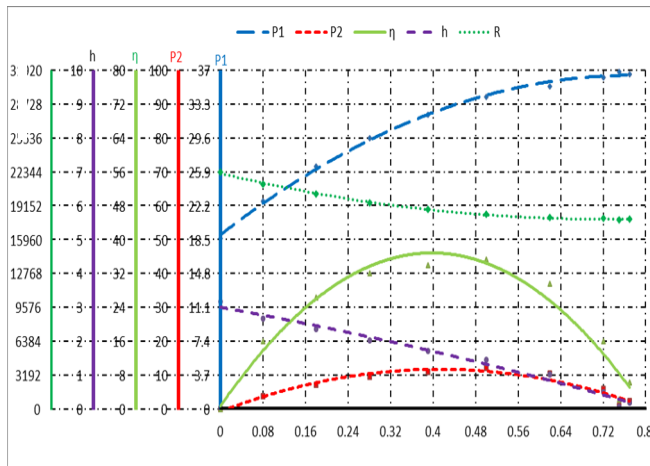

Connector Housing
JST:S4B-PH-SM4-TB
YEONHO:20022WR-04
Waho:HA2001-4A-S

Pin assignment

No.	SIGNAL
1	FG Output
2	PWM (Hi Active)
3	GND
4	VM (14.4V)

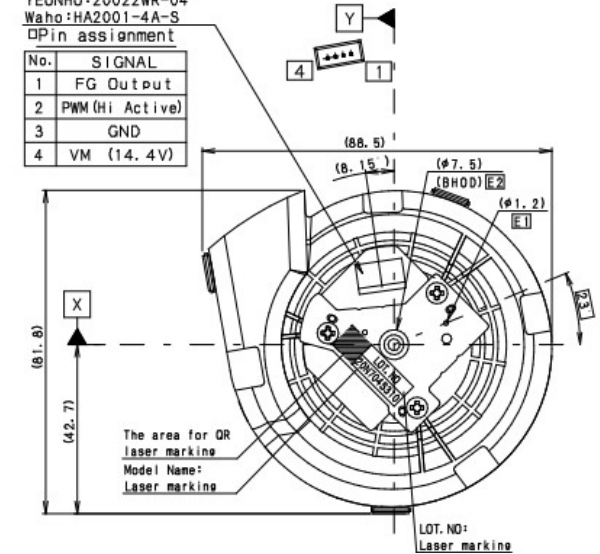

P1: Input power **P2:** Output Power **η:** Effectiveness **R:** Rotating speed **h:** Static pressure

Item	Rated voltage (V)	Rated speed (rpm)	Rated current (A)	Rated power (W)	Maximum static pressure (kPa)	Maximum air volume (m³/min)	SPL noise (dB (A))
Parameter	14.4	15100	1.6	23	3	0.63	68

Robot Cleaner – Blower Unit



22N709Q140

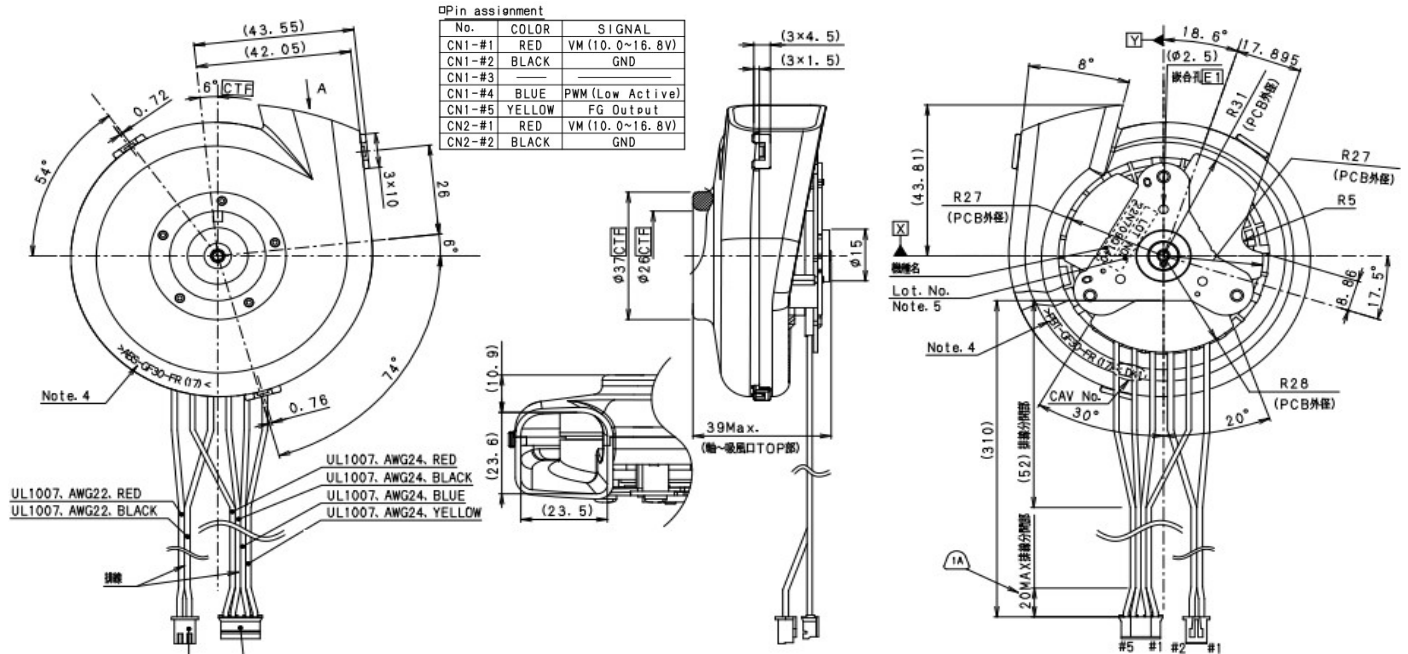
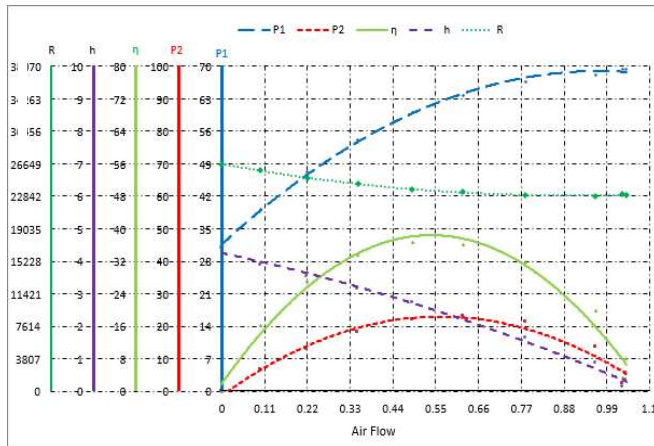

P1: Input power **P2:** Output Power **η:** Effectiveness **R:** Rotating speed **h:** Static pressure

Item	Rated voltage (V)	Rated speed (rpm)	Rated current (A)	Rated power (W)	Maximum static pressure (kPa)	Maximum air volume (m³/min)	SPL noise (dB (A))
Parameter	14.4	22500	4.5	64.8	4	0.99	75

Robot Cleaner – Motor for Blower

Blower (Standard product)	20N704K500 B	20N704P110 A	22N709P230 D	35N048P010
				
Rotor outer diameter [mm]	Φ25	Φ25	Φ27	Φ44.3
Motor height [mm]	13.4	13.4	18.6	26.8
Voltage [V]	12	13	14.4	18
No-load speed [rpm]	16500	23000	29000	28800
No-load current [A]	0.4	0.5	0.6	0.8
Function	PWM/FG	PWM/FG	PWM/FG/SS	PWM/FG

Robot Cleaner – Motor for Blower



20N704K500 B

Performance Curve@12V

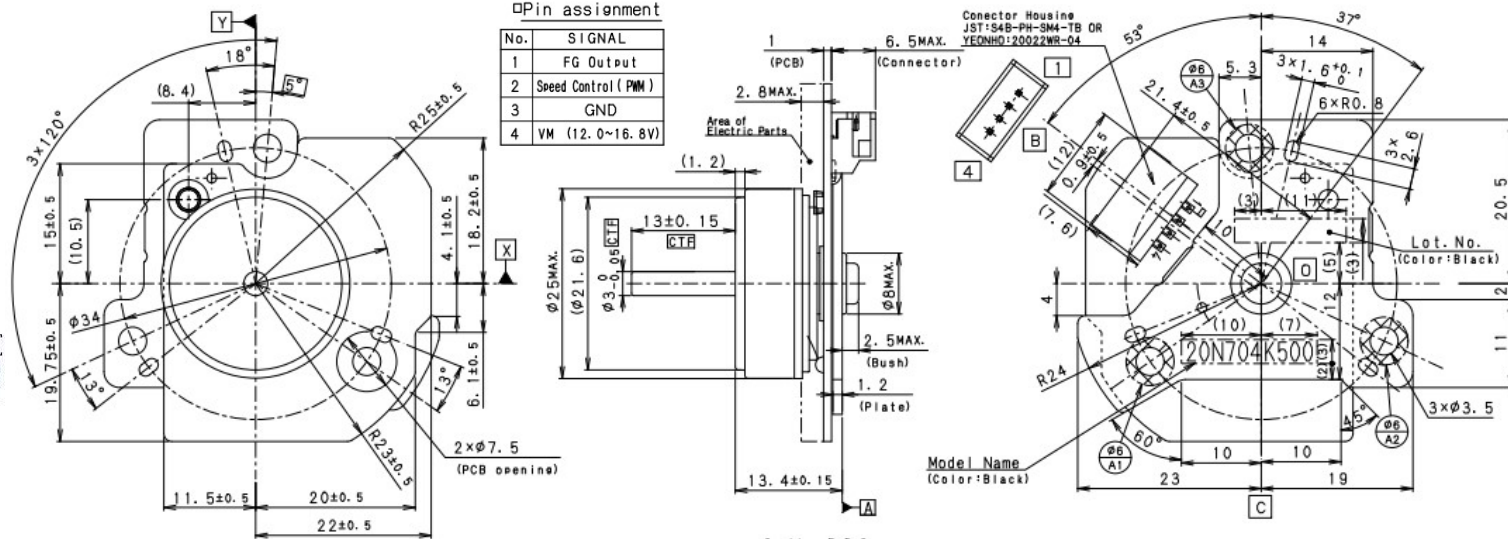
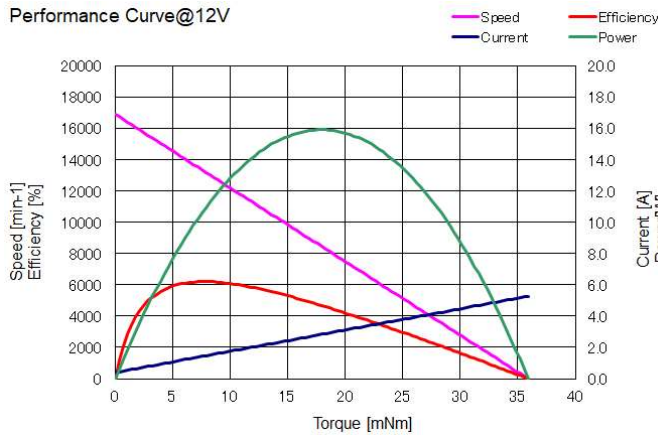

Item	Rated voltage (V)	No-load speed (rpm)	No-load current (A)	Rated speed (rpm)	Rated current (A)	Maximum power (W)	SPL noise (dB (A))
Parameter	12	16500	0.4	13500	1.4	15.9	40

Robot Cleaner – Motor for Blower



20N704P110 A

Performance Curve@13V

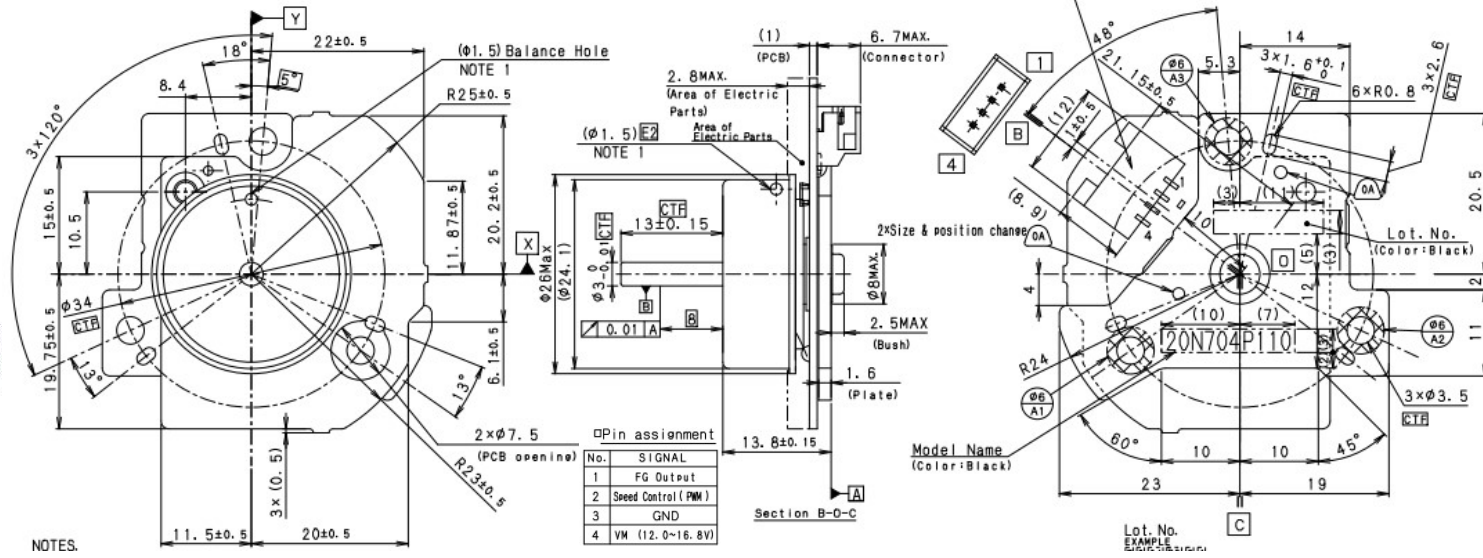
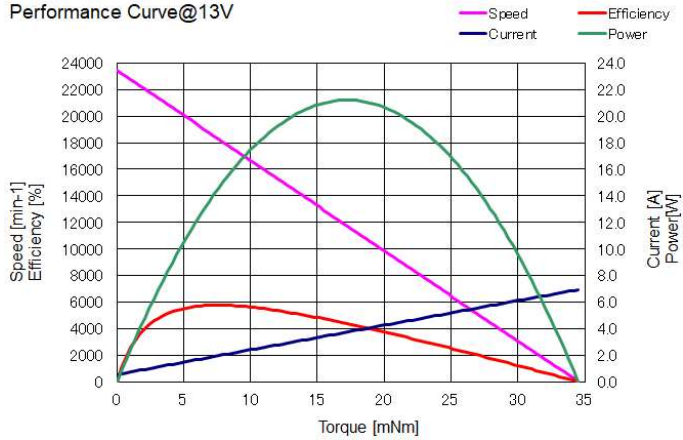

Item	Rated voltage (V)	No-load speed (rpm)	No-load current (A)	Rated speed (rpm)	Rated current (A)	Maximum power (W)	SPL noise (dB (A))
Parameter	13	23000	0.6	16700	1.75	21.2	50

Robot Cleaner – Motor for Blower



22N709P230 D

Performance Curve@14.4V

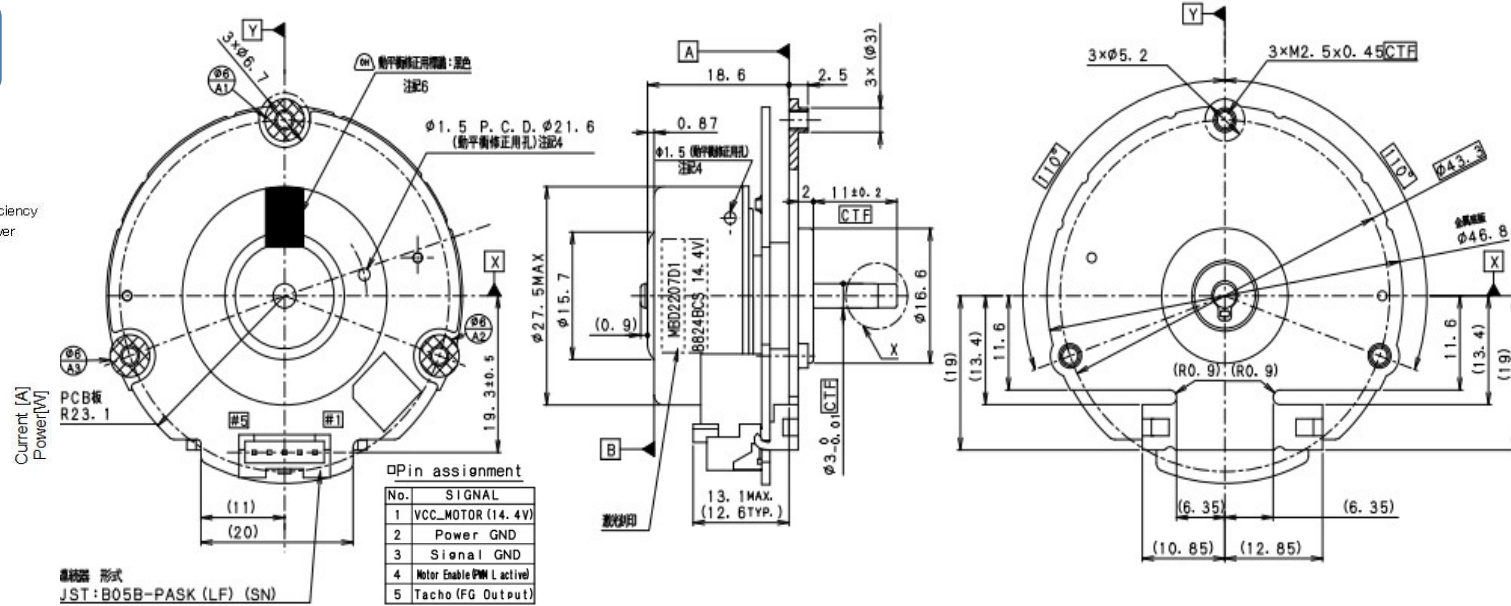
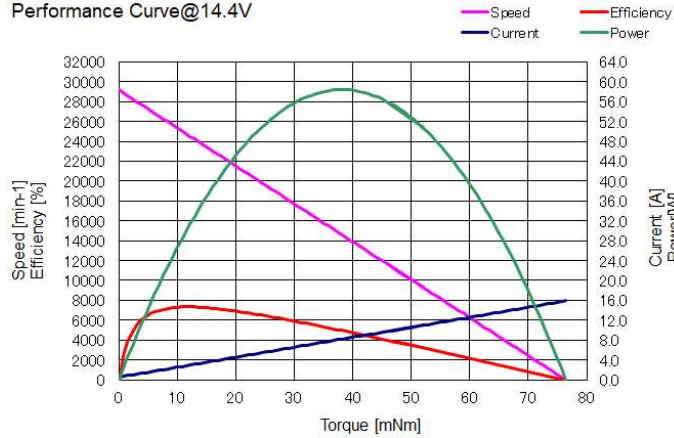

Item	Rated voltage (V)	No-load speed (rpm)	No-load current (A)	Rated speed (rpm)	Rated current (A)	Maximum power (W)	SPL noise (dB (A))
Parameter	14.4	29000	0.6	24800	2.8	58.4	65

Robot Cleaner – Motor for Blower



35N048P010

Performance Curve@18V

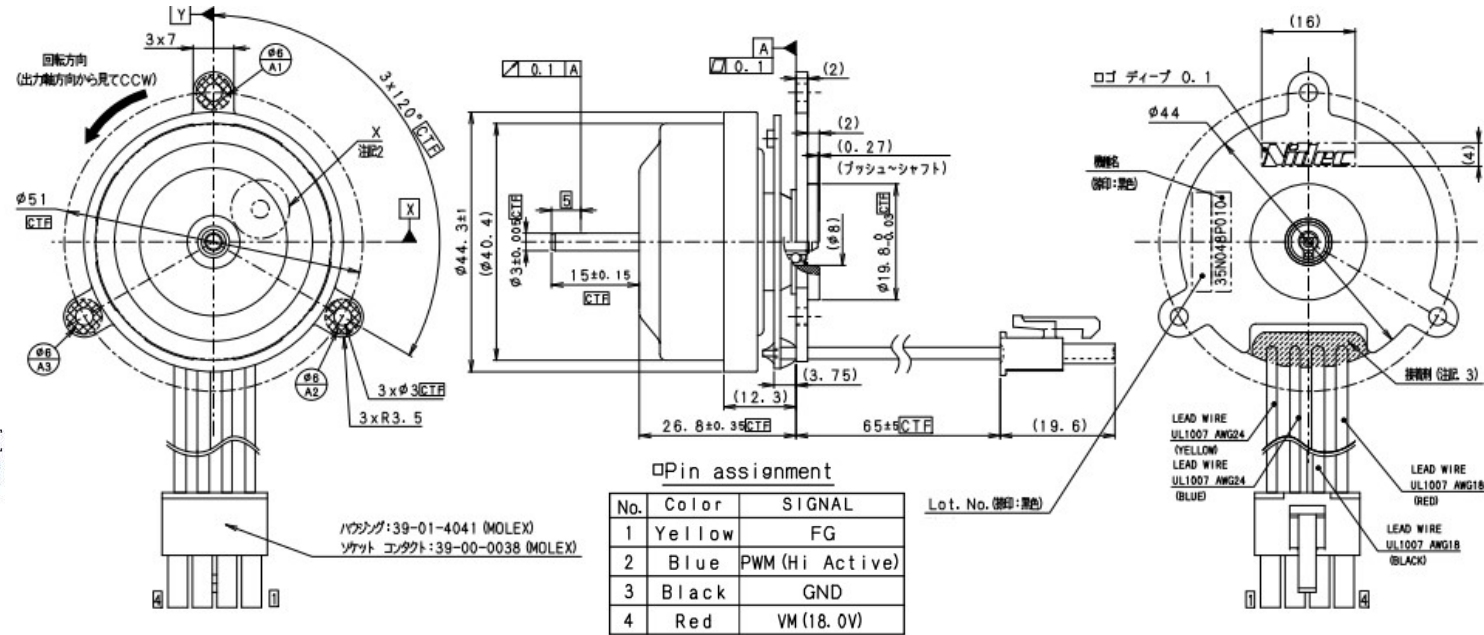
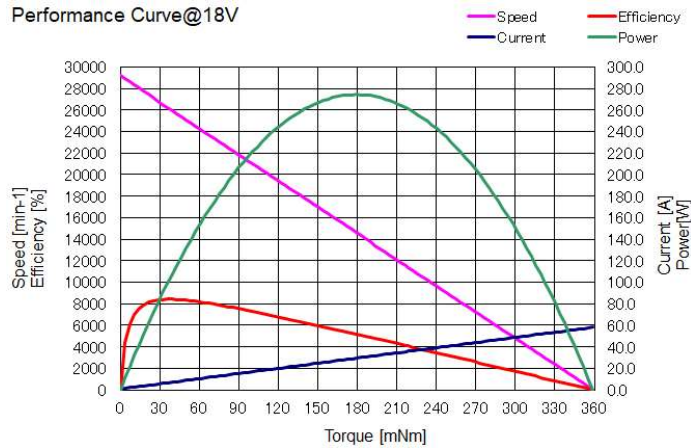

Item	Rated voltage (V)	No-load speed (rpm)	No-load current (A)	Rated speed (rpm)	Rated current (A)	Maximum power (W)	SPL noise (dB (A))
Parameter	18	28800	0.8	25900	7.1	274	60

Robot Cleaner - Motor for Wheel



20N704RC70

In development

Performance Curve@14.4V

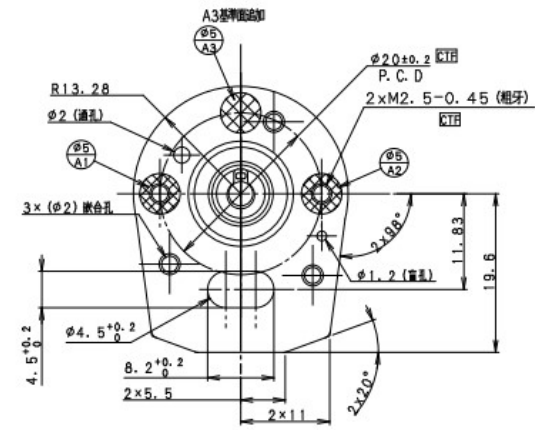
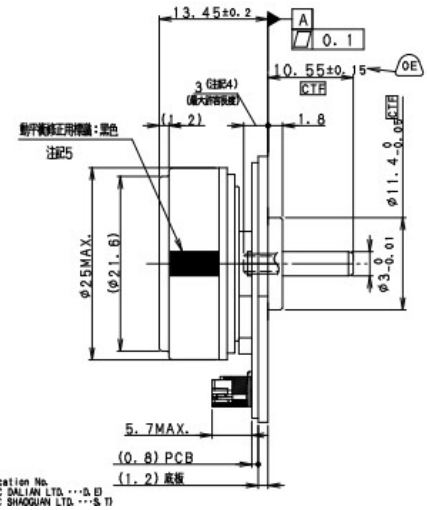
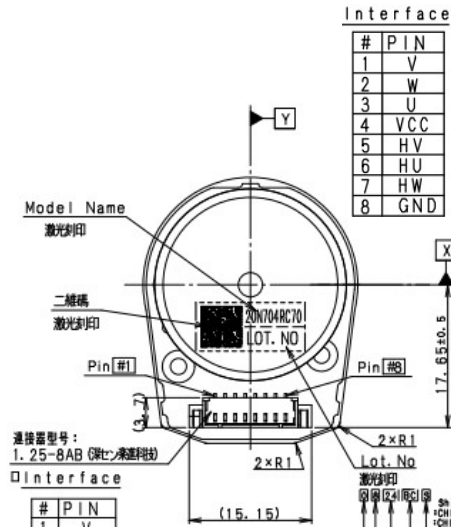
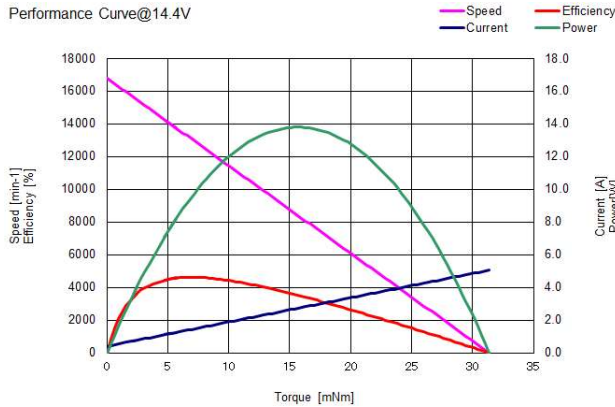

Item	Rated voltage (V)	No-load speed (rpm)	No-load current (A)	Rated speed (rpm)	Rated current (A)	Maximum power (W)	SPL noise (dB (A))
Parameter	14.4	16800	0.4	13200	1.4	13.8	45

Robot Cleaner - Motor for Wheel



20N275M020

Performance Curve@18V

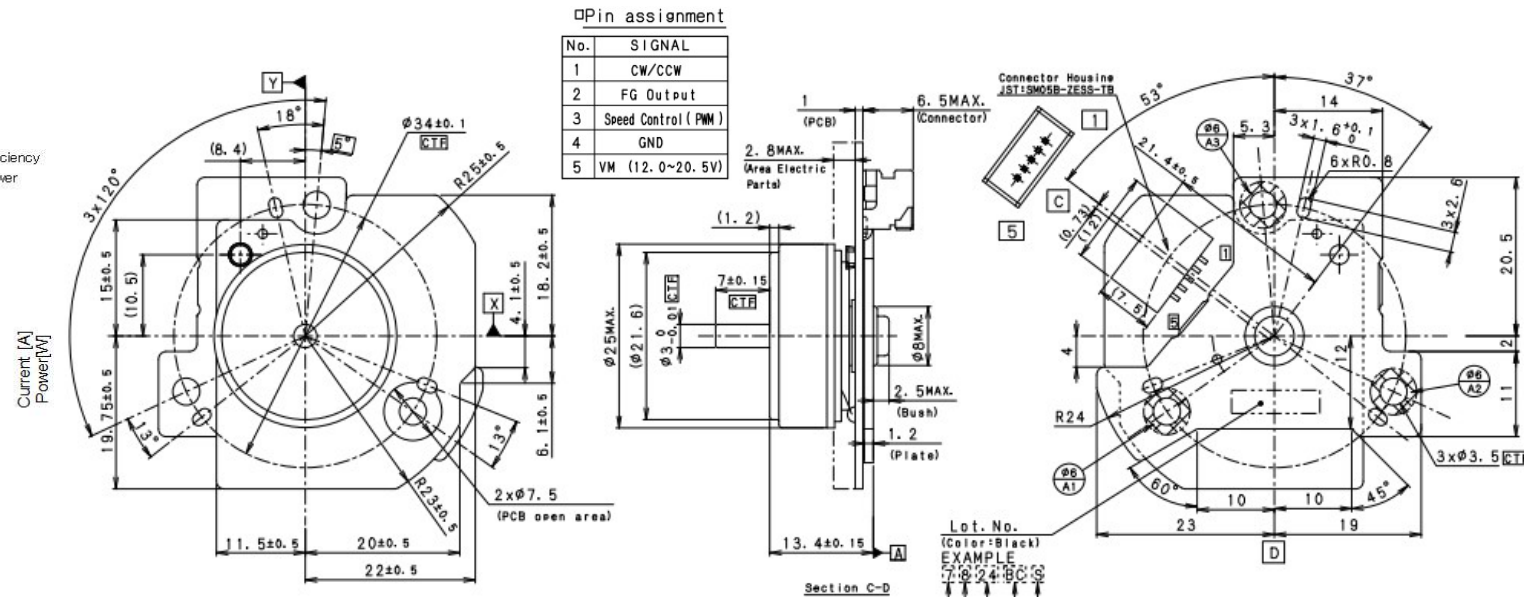
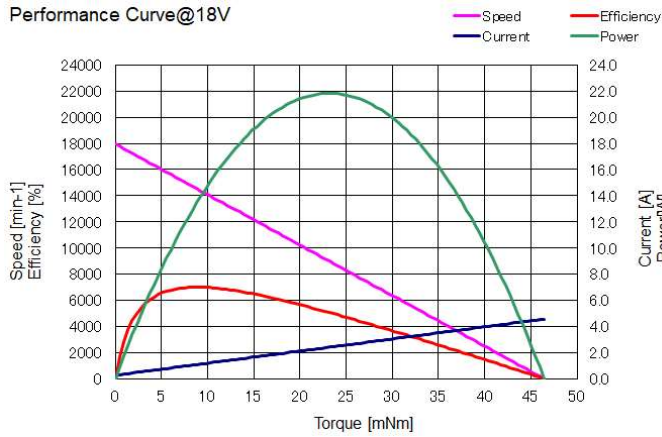

Item	Rated voltage (V)	No-load speed (rpm)	No-load current (A)	Rated speed (rpm)	Rated current (A)	Maximum power (W)	SPL noise (dB (A))
Parameter	18	18000	0.3	14500	1.1	21.8	40

Robot Cleaner - Motor for Brush



22N704RC80

In development

Performance Curve@14.4V

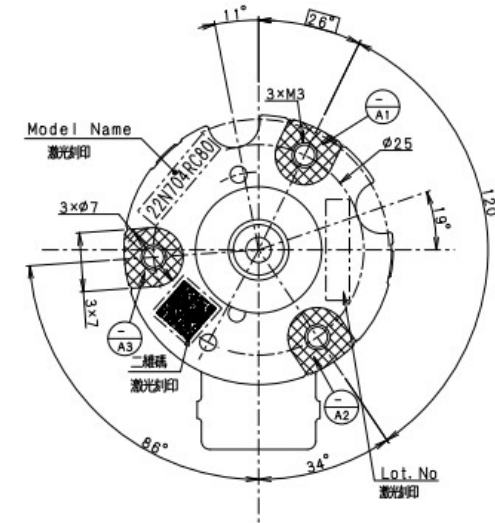
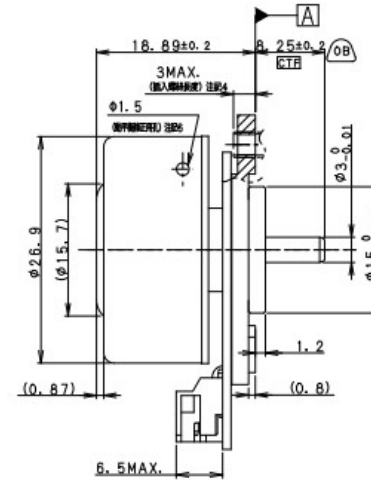
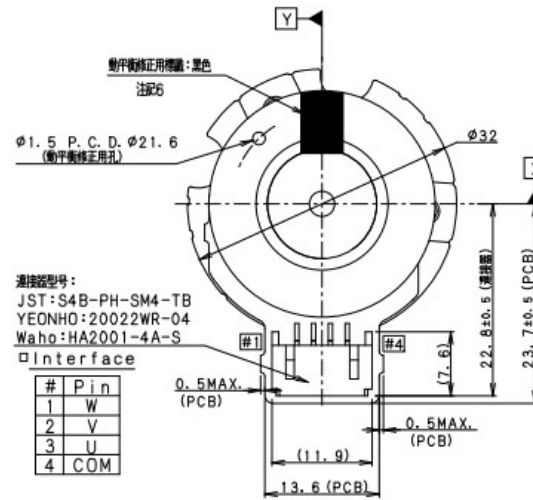
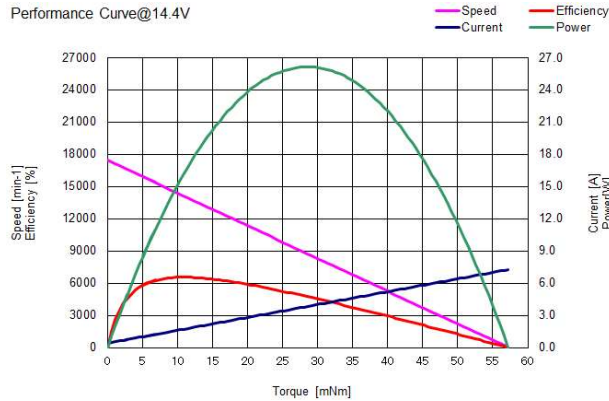

Item	Rated voltage (V)	No-load speed (rpm)	No-load current (A)	Rated speed (rpm)	Rated current (A)	Maximum power (W)	SPL noise (dB (A))
Parameter	14.4	18000	0.4	14300	1.6	26	45

Robot Cleaner – Motor for LDS



24N (LDS)

In development

Performance Curve

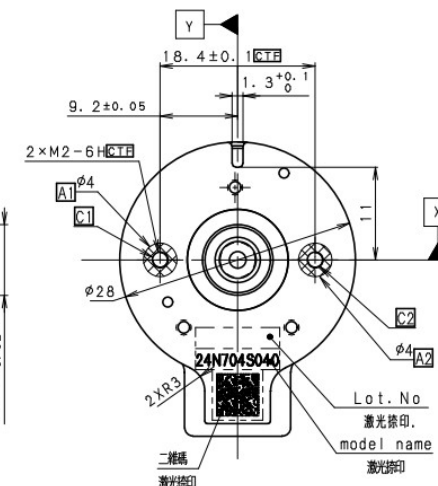
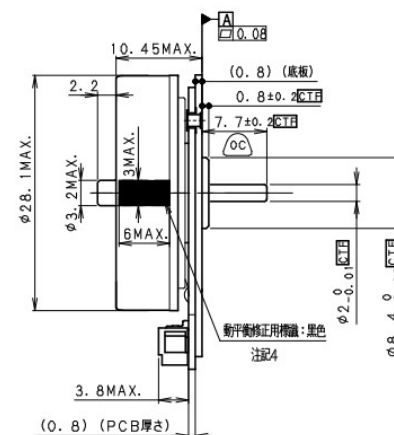
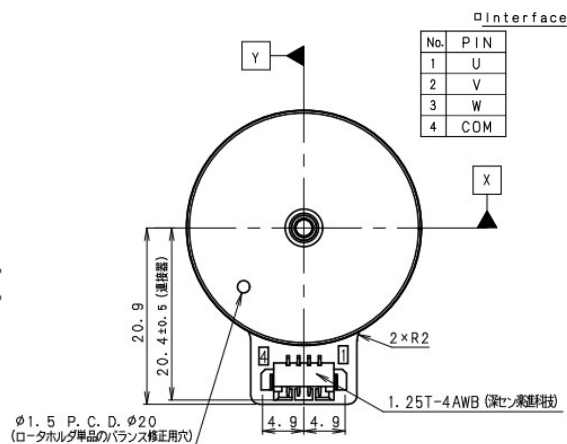
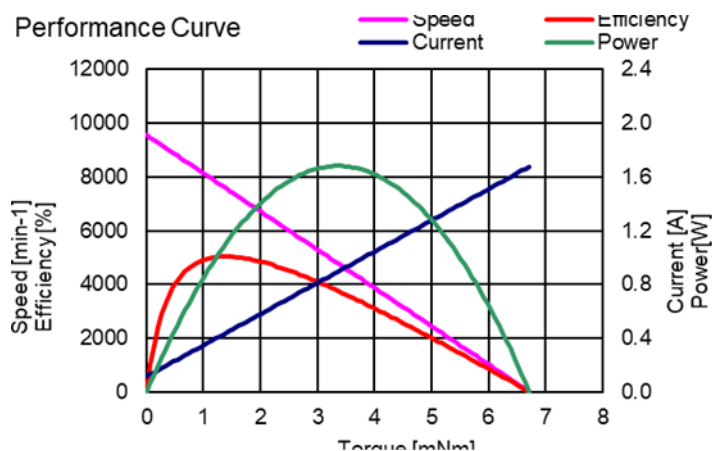

Item	Rated voltage (V)	No-load speed (rpm)	No-load current (A)	Rated speed (rpm)	Rated current (A)	Maximum power (W)	SPL noise (dB (A))
Parameter	5	9500	0.1	7400	0.5	4	30

Robot Cleaner – Motor for LDS & Side brush



24N704S040

In development

Performance Curve@14.4V

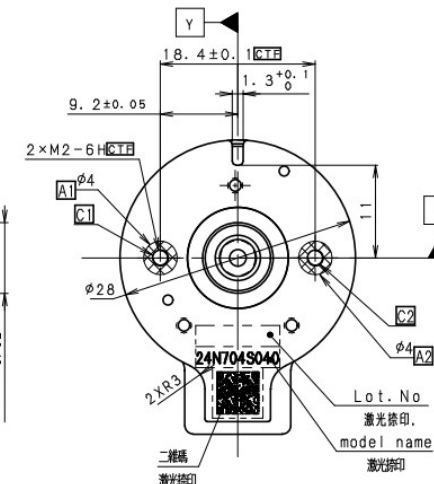
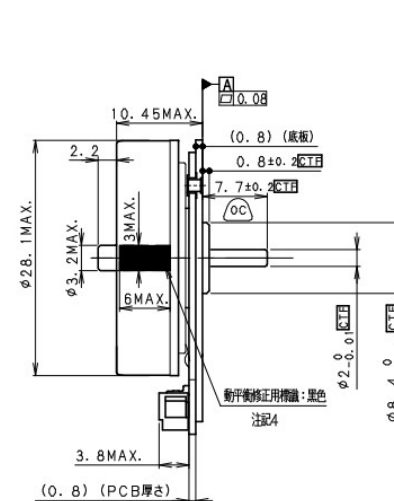
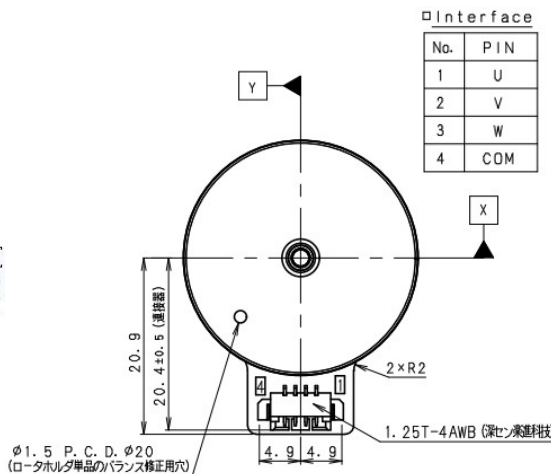
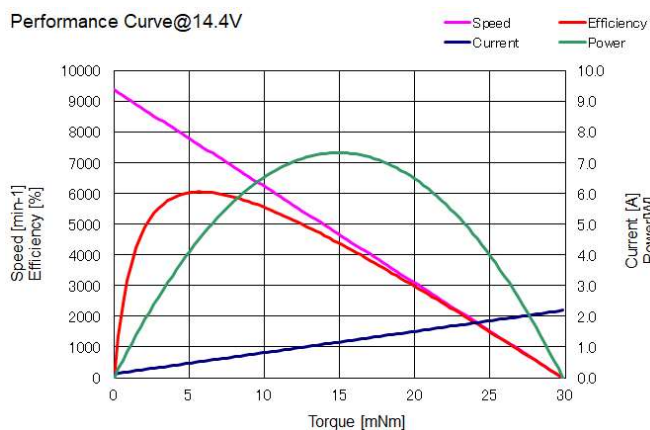

Item	Rated voltage (V)	No-load speed (rpm)	No-load current (A)	Rated speed (rpm)	Rated current (A)	Maximum power (W)	SPL noise (dB (A))
Parameter	14.4	9350	0.15	7680	0.6	7.3	30

Robot Cleaner - Motor for Mop drive



20N709R050/R050 N

Performance Curve@12V

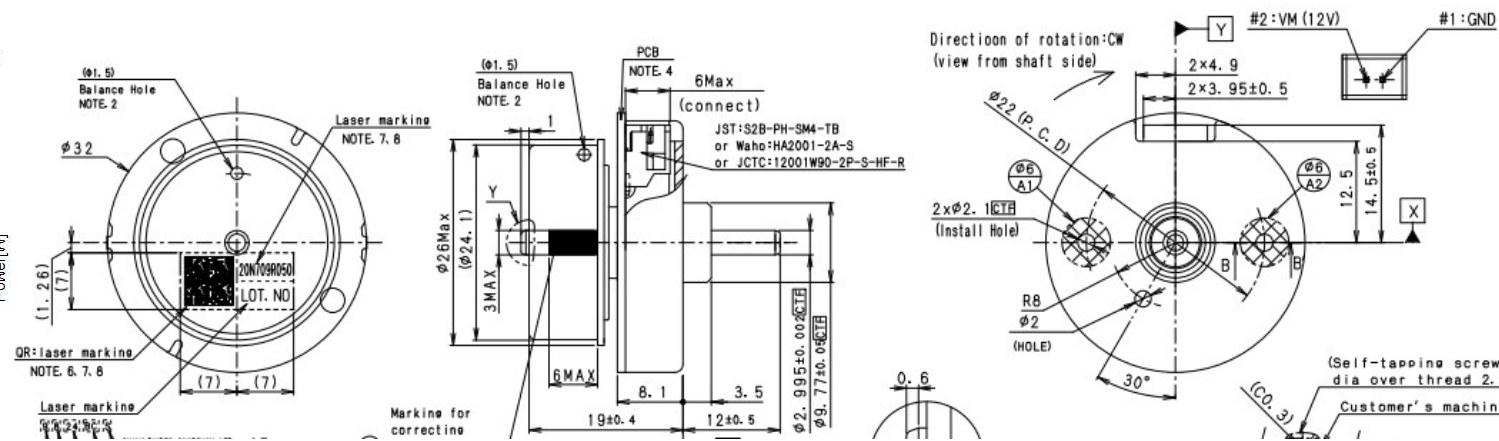
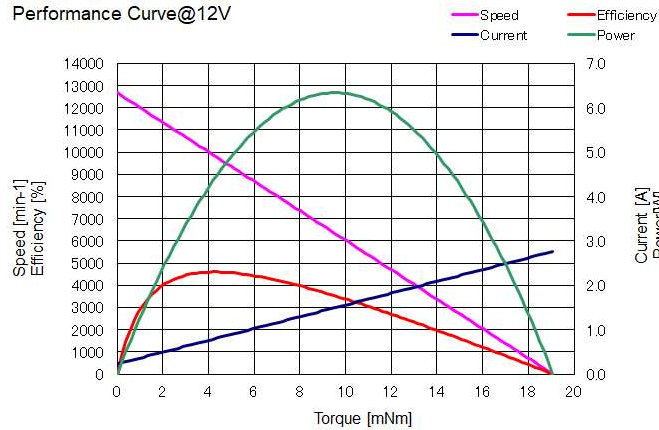

Item	Rated voltage (V)	No-load speed (rpm)	No-load current (A)	Rated speed (rpm)	Rated current (A)	Maximum power (W)	SPL noise (dB (A))
Parameter	12	12600	0.3	10000	0.8	6.3	40

Nidec

All for dreams