

TX6211C High Speed Low Dropout Middle Current Voltage Regulators

Features

- Output Voltage Range: 1.0V to 5.0V (selectable in 100mV steps)
- Highly Accurate: $\pm 2\%$
- Dropout Voltage: 0.17V @ 100mA (3.3V type)
- High Ripple Rejection: 70dB (10 kHz)
- Low Power Consumption: 70 μ A (TYP.)
- Maximum Output Current : 300mA
- Standby Current : less than 2 μ A
- Internal protector: current limiter
- Internal discharge MOS
- SOT-23-5L ,DFNWB1 \times 1-4L,SOT-353 and SOT-343 package

Applications

- Mobile phones
- Cordless phones
- Cameras, Video cameras
- Portable games
- Portable AV equipment
- Reference voltage
- Battery powered equipment

General Description

The TX6211C series are highly precise, low noise, positive voltage LDO regulators manufactured using CMOS processes. The series achieves high ripple rejection and low dropout and consists of a standard voltage source, an error correction, current limiter and a phase compensation circuit plus a driver transistor. Output voltage is selectable in 100mV increments within a range of 1.5V ~ 5.0V. The series is also compatible with low

ESR ceramic capacitors which give added output stability. This stability can be maintained even during load fluctuations due to the excellent transient response of the series.

The current limiter's feedback circuit also operates as a short protect for the output current limiter and the output pin. The CE function enables the output to be turned off, resulting in greatly reduced power consumption.

Typical Application Circuit

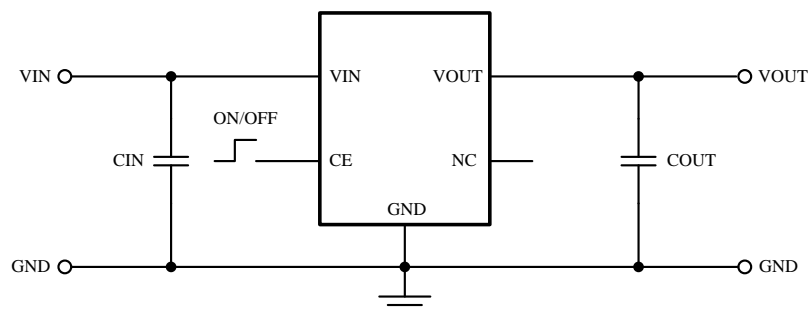

Caution: 1. The above connection diagram and constant will not guarantee successful operation. Perform thorough evaluation using the actual application to set the constant.

2. Input capacitor (CIN): 1.0 μ F or more, Output capacitor (COUT): 1.0 μ F or more (tantalum capacitor)

3. A general series regulator may oscillate, depending on the external components selected. Check that no oscillation occurs with the application using the above capacitor.

TX6211C High Speed Low Dropout Middle Current Voltage Regulators

Order Information

TX6211C①②③④⑤⑥

Designator	Symbol	Description	Designator	Symbol	Description
①		CE Pin Logic :	⑤		Package Type :
	A	Active 'High' (pull-down resistor built in)		M	SOT-23-5L
	B	Active 'High' (no pull-down resistor built in)		K	SOT-353
	C	Active 'Low' (pull-up resistor built in)		C	SOT-343
	D	Active 'Low' (no pull-up resistor built in)	D	DFNWB1*1-4L	
②③	10-60	Output Voltage: e.g. 20 = 2.0V 30 = 3.0V etc.	⑥	Device Orientation :	
④	2	Output Voltage : 100mV increments e.g. ②=3, ③=8, ④=2 represents 3.8V		R	Embossed Tape : Standard Feed
	A	Output Voltage : 50mV increments e.g. ②=3, ③=8, ④=A represents 3.85V	L	Embossed Tape : Reverse Feed	

Block Diagram

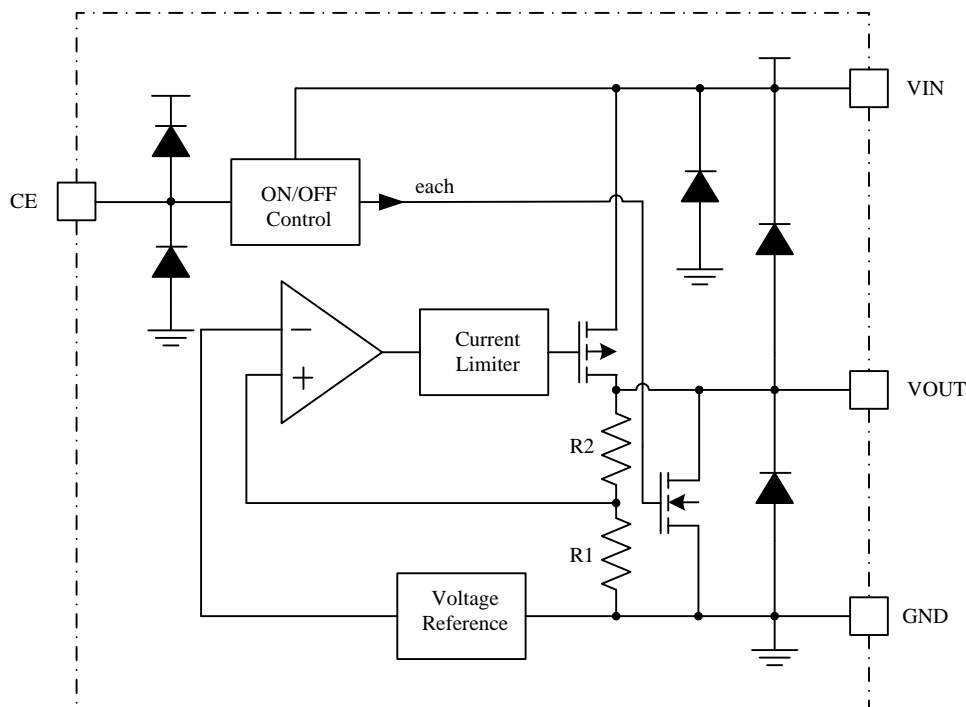

TX6211C High Speed Low Dropout Middle Current Voltage Regulators

Pin configuration

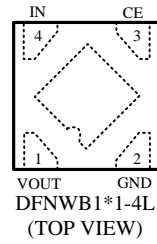
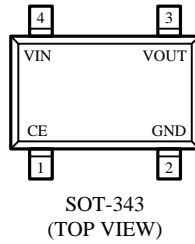
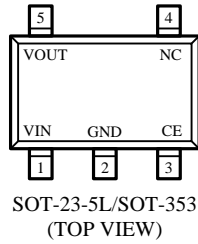

Pin Assignment

Pin Number			Pin Name	Function
SOT-23-5L /SOT-353	DFNWB1*1-4L	SOT-343		
1	4	4	VIN	Supply power
2	2	2	GND	Ground
3	3	1	CE	Enable pin
4	-	-	NC	NC
5	1	3	VOUT	Voltage output

Marking Rule

- SOT-23-5L, SOT-353, SOT-343

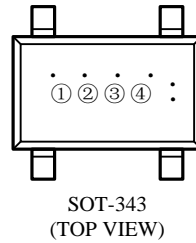
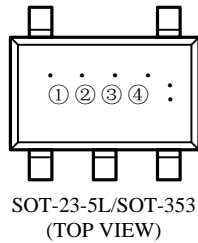

- ① Represents the product name

Symbol	Product Name
4	TX6211C◆◆◆◆◆◆◆◆

- ② Represents the type of regulator

Voltage(V)	1.0~3.0	3.1~6.0	1.05~3.05	3.15~6.05	Product Name
Symbol	V	A	E	L	TX6211CA◆◆◆◆◆◆◆◆
	X	B	F	M	TX6211CB◆◆◆◆◆◆◆◆
	Y	C	H	N	TX6211CC◆◆◆◆◆◆◆◆
	Z	D	K	P	TX6211CD◆◆◆◆◆◆◆◆

TX6211C High Speed Low Dropout Middle Current Voltage Regulators

③ Represents the Output Voltage

Symbol	Output Voltage(V)			
0		3.1		3.15
1		3.2		3.25
2		3.3		3.35
3		3.4		3.45
4		3.5		3.55
5		3.6		3.65
6		3.7		3.75
7		3.8		3.85
8		3.9		3.95
9	1.0	4.0	1.05	4.05
A	1.1	4.1	1.15	4.15
B	1.2	4.2	1.25	4.25
C	1.3	4.3	1.35	4.35
D	1.4	4.4	1.45	4.45
E	1.5	4.5	1.55	4.55

Symbol	Output Voltage(V)			
F	1.6	4.6	1.65	4.65
H	1.7	4.7	1.75	4.75
K	1.8	4.8	1.85	4.85
L	1.9	4.9	1.95	4.95
M	2.0	5.0	2.05	5.05
N	2.1		2.15	
P	2.2		2.25	
R	2.3		2.35	
S	2.4		2.45	
T	2.5		2.55	
U	2.6		2.65	
V	2.7		2.75	
X	2.8		2.85	
Y	2.9		2.95	
Z	3.0		3.05	

④ Represents the assembly lot no.

0~9, A~Z repeated (G, I, J, O, Q, W excepted)

- WBFBP1X1-4L

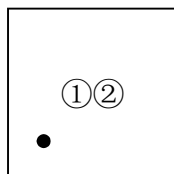

① Represents the Output Voltage

Symbol	Voltage(V)	Symbol	Voltage(V)	Symbol	Voltage(V)	Symbol	Voltage(V)
A	1.1	K	2.1	U	3.1	5	4.1
B	1.2	L	2.2	V	3.2	6	4.2
C	1.3	M	2.3	W	3.3	7	4.3
D	1.4	N	2.4	X	3.4	8	4.4
E	1.5	O	2.5	Y	3.5	9	4.5
F	1.6	P	2.6	Z	3.6	+	4.6
G	1.7	Q	2.7	1	3.7	-	4.7
H	1.8	R	2.8	2	3.8	*	4.8
I	1.9	S	2.9	3	3.9	?	4.9
J	2.0	T	3.0	4	4.0	=	5.0

② Represents the assembly lot No.

0~9, A~Z repeated (G, I, J, O, Q, W excepted)

TX6211C High Speed Low Dropout Middle Current Voltage Regulators

Absolute Maximum Ratings

Parameter	Symbol	Maximum Rating	Unit
Input Voltage	V_{IN}	$V_{SS}-0.3 \sim V_{SS}+8$	V
	$V_{ON/OFF}$	$V_{SS}-0.3 \sim V_{IN}+0.3$	
Output Voltage	V_{OUT}	$V_{SS}-0.3 \sim V_{IN}+0.3$	
Power Dissipation	P_D	SOT-23-5L	400
		SOT-353,SOT-343	250
		DFNWB1*1-4L	100
Operating Ambient Temperature	T_{opr}	$-40 \sim +85$	°C
Storage Temperature	T_{stg}	$-40 \sim +125$	

Caution: The absolute maximum ratings are rated values exceeding which the product could suffer physical damage. These values must therefore not be exceeded under any conditions.

Electrical Characteristics

Parameter	Symbol	Condition	Min	Typ	Max	Unit
Output Voltage	$V_{OUT(E)}$	$V_{IN} = V_{OUT(S)} + 1.0 \text{ V}$, $I_{OUT} = 30 \text{ mA}$	$V_{OUT(S)} \times 0.98$	$V_{OUT(S)}$	$V_{OUT(S)} \times 1.02$	V
Output Current	I_{OUT}	$V_{IN} \geq V_{OUT(S)} + 1.0 \text{ V}$	300	-	-	mA
Dropout Voltage	V_{drop}	$I_{OUT} = 50 \text{ mA}$	-	0.12	0.20	V
		$I_{OUT} = 100 \text{ mA}$	-	0.30	0.45	
Line Regulations	$\frac{\Delta V_{OUT1}}{\Delta V_{IN} \bullet V_{OUT}}$	$V_{OUT(S)} + 0.5 \text{ V} \leq V_{IN} \leq 7 \text{ V}$ $I_{OUT} = 30 \text{ mA}$	-	0.10	0.2	%/V
Load Regulation	ΔV_{OUT2}	$V_{IN} = V_{OUT(S)} + 1.0 \text{ V}$ $1.0 \text{ mA} \leq I_{OUT} \leq 100 \text{ mA}$	-	50	100	mV
Output Voltage Temperature Characteristics	$\frac{\Delta V_{OUT}}{\Delta T_a \bullet V_{OUT}}$	$V_{IN} = V_{OUT(S)} + 1.0 \text{ V}$, $I_{OUT} = 10 \text{ mA}$ $-40^\circ\text{C} \leq T_a \leq 85^\circ\text{C}$	-	± 100	-	ppm/°C
Supply Current	I_{SS1}	$V_{IN} = V_{OUT(S)} + 1.0 \text{ V}$	-	70	-	μA
Input Voltage	V_{IN}	-	2.0	-	7.0	V
Ripple-Rejection	PSRR	$V_{IN} = V_{OUT(S)} + 1.0 \text{ V}$, $f = 10 \text{ kHz}$ $V_{rip} = 0.5 \text{ V}_{rms}$, $I_{OUT} = 50 \text{ mA}$	-	70	-	dB
Short-circuit Current	I_{short}	$V_{IN} = V_{OUT(S)} + 1.0 \text{ V}$, V_{CE} on $V_{OUT} = \text{gnd}$	-	40	-	mA
CE "High" Voltage	V_{CEH}	-	1.6	-	-	V
CE "Low" Voltage	V_{CEL}	-	-	-	0.8	V
CE "High" Current (no resistor built in)	I_{CEH}	$V_{IN} = V_{CE} = V_{OUT(T)} + 1.0 \text{ V}$	-0.1	-	0.1	μA
CE "Low" Current (no resistor built in)	I_{CEL}	$V_{IN} = V_{OUT(T)} + 1.0 \text{ V}$, $V_{CE} = V_{SS}$	-0.1	-	0.1	μA
Inrush Current	I_{RUSH}	$V_{IN} = V_{OUT(T)} + 1 \text{ V}$, $C_L = 47 \mu\text{F}$, $V_{CE} = 0$ → $V_{OUT(T)} + 1 \text{ V}$ (Only when rising and within 1ms)			800	mA

TX6211C High Speed Low Dropout Middle Current Voltage Regulators

Typical Performance Characteristics

1. Quiescent Current VS Input Voltage

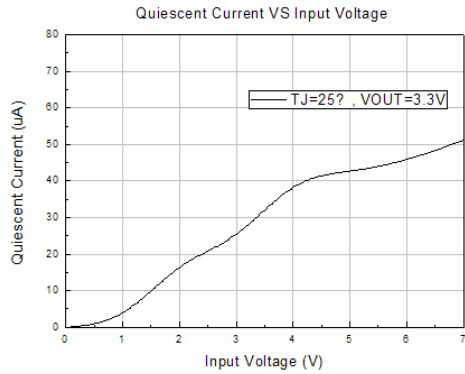

2. Output Voltage VS Input Voltage

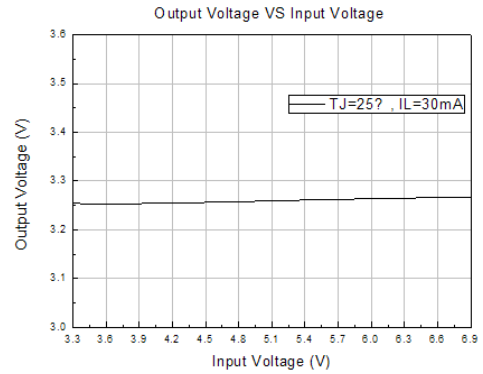

3. Output Current Limit VS Input Voltage

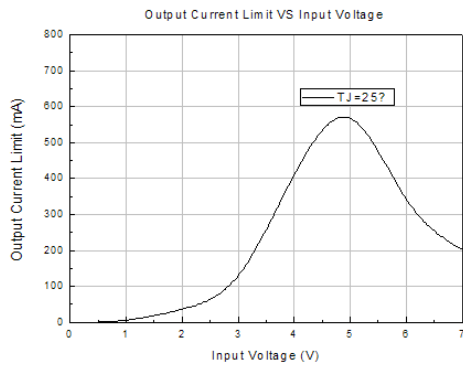

4. GND Pin Current VS Input Voltage

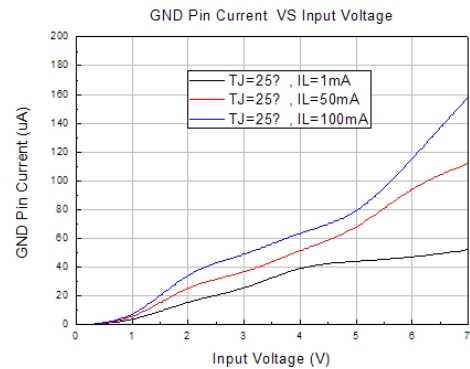

5. GND Pin Current VS Output Current

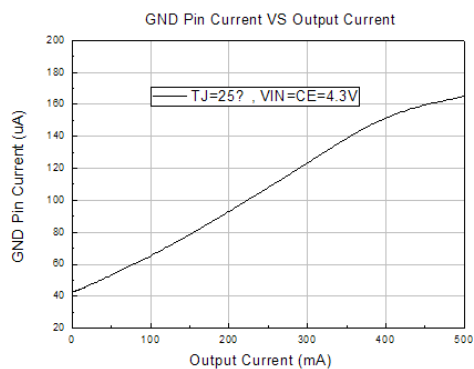

6. Quiescent Current VS Temperature

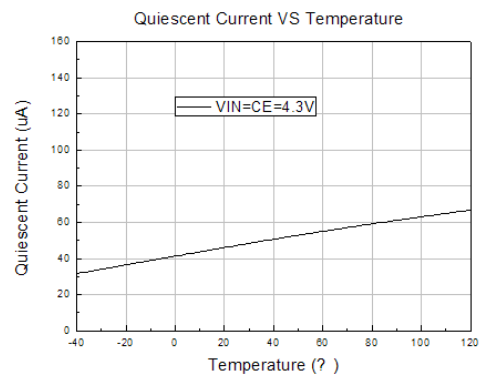

TX6211C High Speed Low Dropout Middle Current Voltage Regulators

7. Output Current Limit VS Temperature

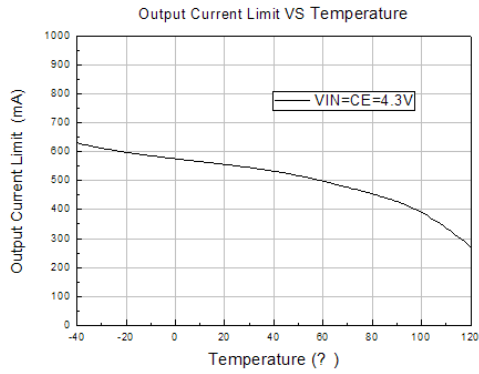

8. Output Voltage VS Temperature

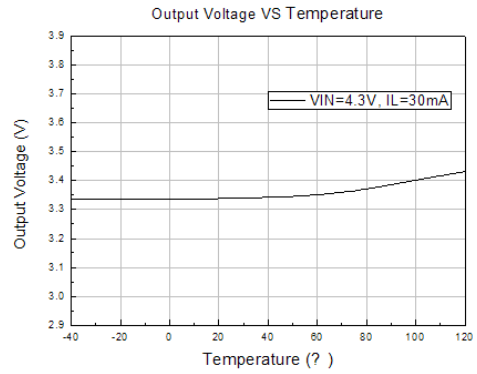

9. Dropout Voltage VS Temperature

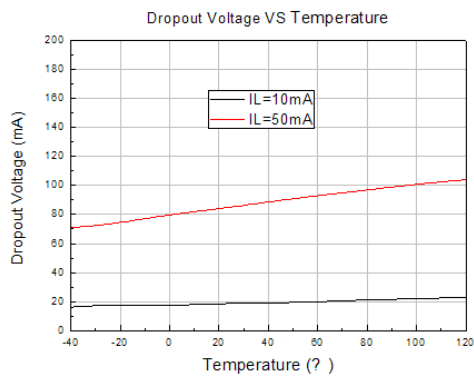

10. CE "High" Voltage VS Temperature

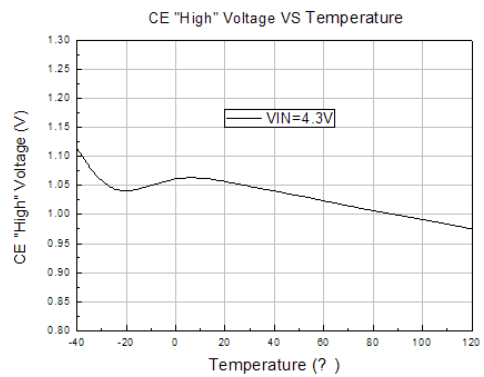

11. CE "Low" Voltage VS Temperature

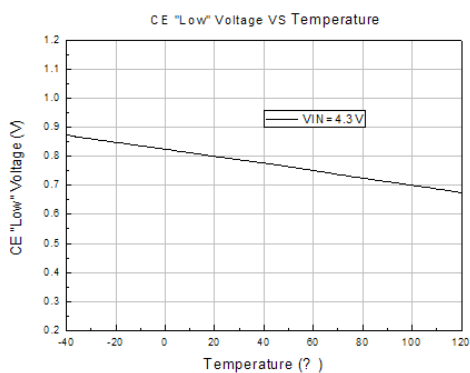

12. Load Regulation VS Temperature

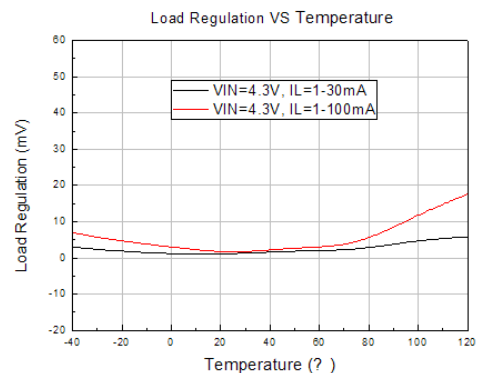

TX6211C High Speed Low Dropout Middle Current Voltage Regulators

13. Input voltage transient response (IL=30mA)

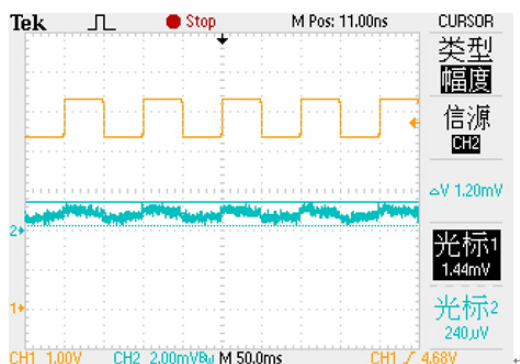

14. Load transient response (IL=0-350-0mA)

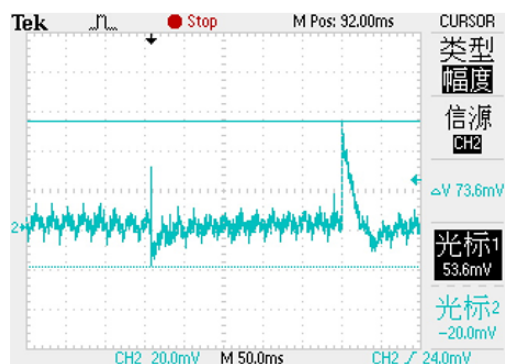

15. Load transient response (IL=10-350-10mA)



16. Ripple-Rejection (IL=50mA, Vpp=1V, F=1KHZ)

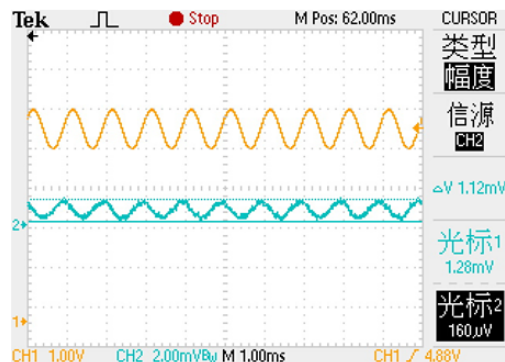

17. CE Opening Time

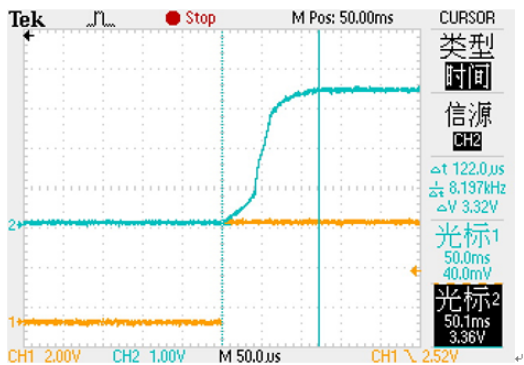

18. CE Turn-off Time

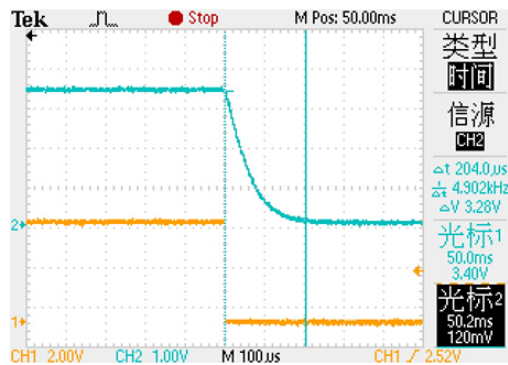

19. Inrush Current

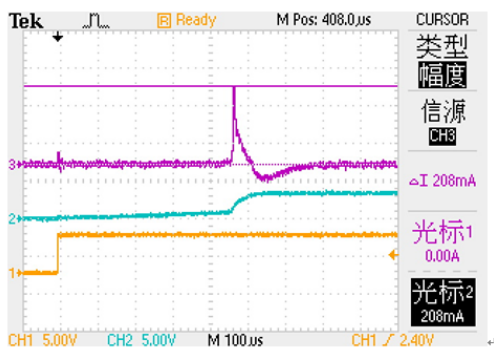

TX6211C High Speed Low Dropout Middle Current Voltage Regulators

Package Information

- SOT-23-5L

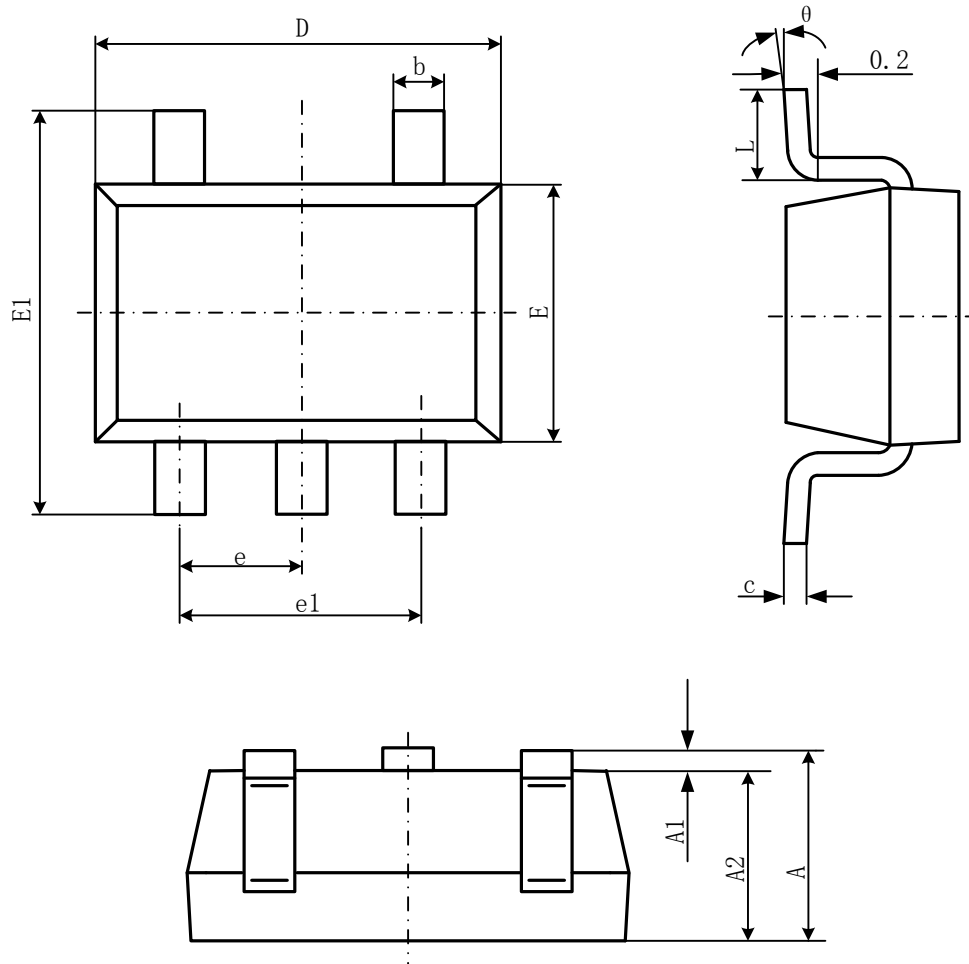

Symbol	Dimensions In Millimeters		Dimensions In Inches	
	Min	Max	Min	Max
A	1.050	1.250	0.041	0.049
A1	0.000	0.100	0.000	0.004
A2	1.050	1.150	0.041	0.045
b	0.300	0.500	0.012	0.020
c	0.100	0.200	0.004	0.008
D	2.820	3.020	0.111	0.119
E	1.500	1.700	0.059	0.067
E1	2.650	2.950	0.104	0.116
e	0.950(BSC)		0.037(BSC)	
e1	1.800	2.000	0.071	0.079
L	0.300	0.600	0.012	0.024
θ	0°	8°	0°	8°

TX6211C High Speed Low Dropout Middle Current Voltage Regulators

● DFNWB1.8x2-6L

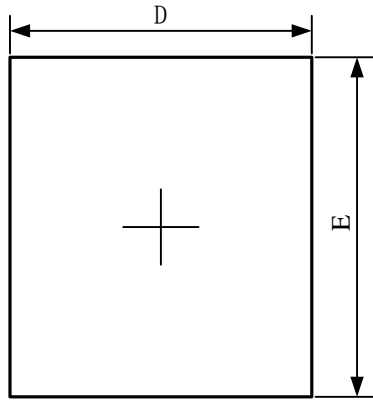

Top View

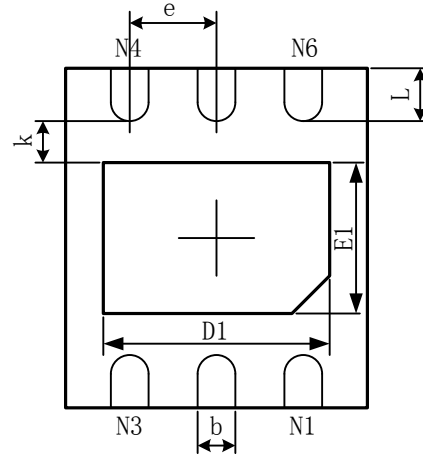

Bottom View

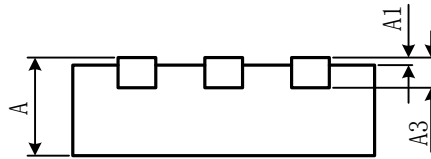

Side View

Symbol	Dimensions In Millimeters		Dimensions In Inches	
	Min	Max	Min	Max
A	0.450/0.550	0.550/0.650	0.180/0.022	0.022/0.026
A1	0.000	0.050	0.000	0.002
A3	0.150REF		0.006REF	
D	1.724	1.876	0.068	0.074
E	1.924	2.076	0.076	0.082
D1	13000	1.500	0.051	0.059
E1	0.800	1.000	0.031	0.039
k	0.200MIN		0.008MIN	
b	0.180	0.280	0.007	0.011
e	0.500TYP		0.020TYP	
L	0.174	0.326	0.007	0.013

TX6211C High Speed Low Dropout Middle Current Voltage Regulators

● SOT-353

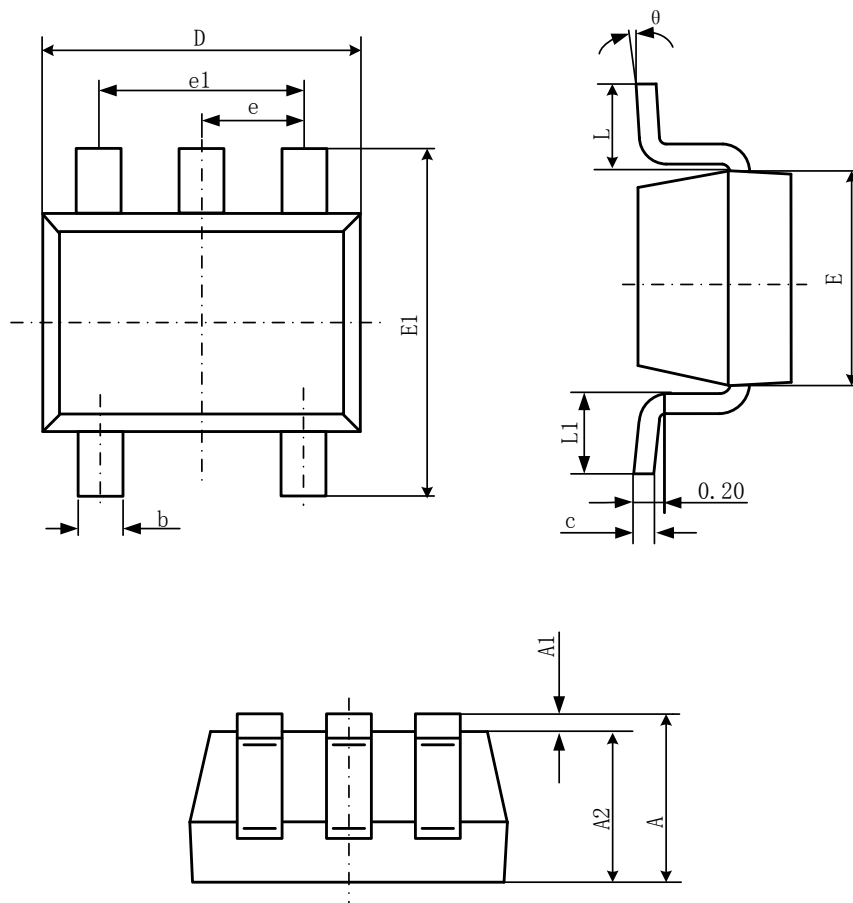

Symbol	Dimensions In Millimeters		Dimensions In Inches	
	Min	Max	Min	Max
A	0.900	1.100	0.035	0.043
A1	0.000	0.100	0.000	0.004
A2	0.900	1.000	0.035	0.039
b	0.150	0.350	0.006	0.014
c	0.080	0.150	0.003	0.006
D	2.000	2.200	0.079	0.087
E	1.150	1.350	0.045	0.053
E1	2.150	2.450	0.085	0.096
e	0.650TYP		0.026TYP	
e1	1.200	1.400	0.047	0.055
L	0.525REF		0.021REF	
L1	0.260	0.460	0.010	0.018
θ	0°	8°	0°	8°

TX6211C High Speed Low Dropout Middle Current Voltage Regulators

● SOT-343

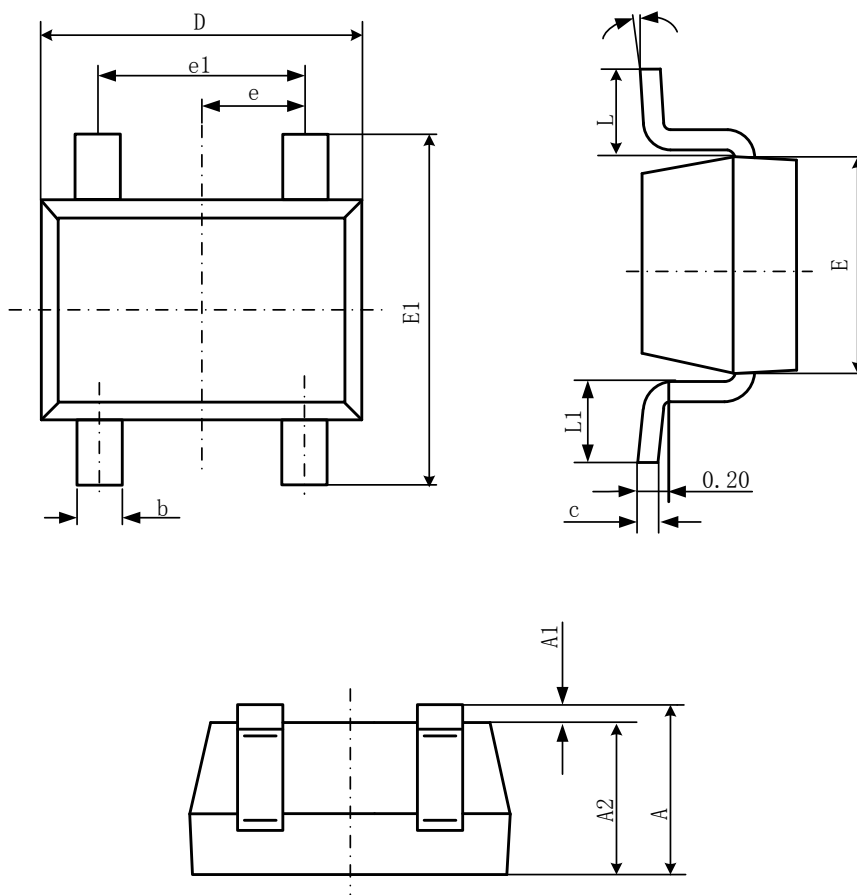

Symbol	Dimensions In Millimeters		Dimensions In Inches	
	Min	Max	Min	Max
A	0.900	1.100	0.035	0.043
A1	0.000	0.100	0.000	0.004
A2	0.900	1.000	0.035	0.039
b	0.150	0.350	0.006	0.014
c	0.080	0.150	0.003	0.006
D	2.000	2.200	0.079	0.087
E	1.150	1.350	0.045	0.053
E1	2.150	2.450	0.085	0.096
e	0.650TYP		0.026TYP	
e1	1.200	1.400	0.047	0.055
L	0.525REF		0.021REF	
L1	0.260	0.460	0.010	0.018
θ	0°	8°	0°	8°

TX6211C High Speed Low Dropout Middle Current Voltage Regulators

© Shenzhen MEIRIT Micro-Electronics Tech Co., Ltd

TX cannot assume responsibility for use of any circuitry other than circuitry entirely embodied in a TX product. No circuit patent license, copyrights or other intellectual property rights are implied. TX reserves the right to make changes to their products or specifications without notice. Customers are advised to obtain the latest version of relevant information to verify, before placing orders, that information being relied on is current and complete.