

CLASS NO.	TITLE 11形回転形エンコーダ規格書 11mm Size Rotary Encoder Specification
-----------	---

1. 一般事項 General (SW01), (SW02)

1-1 適用範囲 SCOPE

この仕様書は主として電子機器に用いる微小電流回路用11形薄型ロータリーエンコーダに適用する。
This specification applies to 11mm size low-profile rotary encoder (incremental type) for microscopic current circuits, used in electronic equipment.

1-2 標準状態 Standard atmospheric conditions

測定は特に指定のない限り、次の状態で行なう。
Unless otherwise specified, the standard range of atmospheric conditions for making measurements and tests is as follows:

温度 Ambient temperature : 15°C to 35°C
 相対湿度 Relative humidity : 25% to 85%
 気圧 Air pressure : 86kPa to 106kPa

但し、疑義を生じえる場合は、次の標準状態で行なう。

If there is any doubt about the results, measurements shall be made within the following limits:

温度 Ambient temperature : 20 ± 1°C
 相対湿度 Relative humidity : 63% to 67%
 気圧 Air pressure : 86kPa to 106kPa

1-3 使用温度範囲

Operating temperature range : -30°C to +70°C

1-4 保存温度範囲

Storage temperature range : -40°C to +85°C

2. 構造 Construction

2-1 寸法 Dimensions

添付組立図による。
Refer to attached drawing.

3. 定格 Rating

3-1 定格容量 (SW01)

Rating : D.C. 5V 10mA (1mA min.)

4. 電気的性能 Electrical characteristics (SW01)

項目 Item	条件 Conditions	規格 Specifications													
4-1 出力番号 Output signal format	<p><Fig 1></p> <table border="1"> <thead> <tr> <th>回転方向 Shaft rotational direction</th> <th>信号 Signal</th> <th>出力波形 Output</th> </tr> </thead> <tbody> <tr> <td rowspan="2">時計方向 C. W.</td> <td>A(A-C端子間) A(Terminal A-C)</td> <td>OFF ON </td> </tr> <tr> <td>B(B-C端子間) B(Terminal B-C)</td> <td>OFF ON </td> </tr> <tr> <td rowspan="2">反時計方向 C. C. W.</td> <td>A(A-C端子間) A(Terminal A-C)</td> <td>OFF ON </td> </tr> <tr> <td>B(B-C端子間) B(Terminal B-C)</td> <td>OFF ON </td> </tr> </tbody> </table>	回転方向 Shaft rotational direction	信号 Signal	出力波形 Output	時計方向 C. W.	A(A-C端子間) A(Terminal A-C)	OFF ON	B(B-C端子間) B(Terminal B-C)	OFF ON	反時計方向 C. C. W.	A(A-C端子間) A(Terminal A-C)	OFF ON	B(B-C端子間) B(Terminal B-C)	OFF ON	<p>A, B2信号の位相差出力とし、詳細は<fig. 1>の通りとする。 (破線はクリックの位置を示す。)</p> <p>2 Phase-different signals (Signal A, signal B) Details shown in <fig. 1>. (The broken line shows detent position.)</p>
		回転方向 Shaft rotational direction	信号 Signal	出力波形 Output											
		時計方向 C. W.	A(A-C端子間) A(Terminal A-C)	OFF ON											
			B(B-C端子間) B(Terminal B-C)	OFF ON											
		反時計方向 C. C. W.	A(A-C端子間) A(Terminal A-C)	OFF ON											
			B(B-C端子間) B(Terminal B-C)	OFF ON											



EC11B152
フリックトルク
18±8mN・m

APPD.	CHKD.	DSGD.	TITLE 11形回転形エンコーダ 11mm Size Rotary encoder	
設3 01.6.16 澤淵	設3 01.6.16 木村	設3 01.6.16 山口	DOCUMENT NO. 5LA211-49 (1/5)	
SYMB	DATE	APPD	CHKD	DSGD

ORI

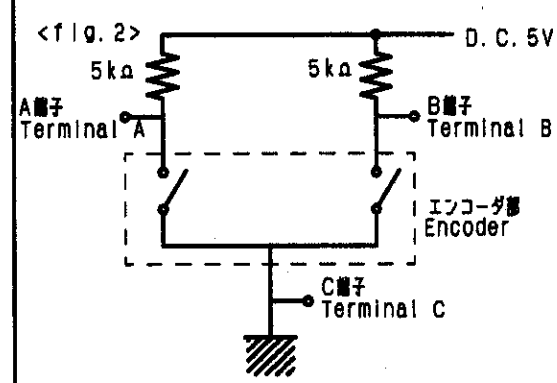
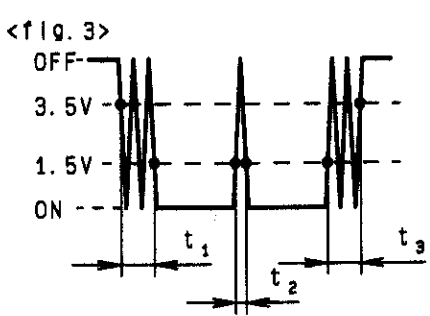
CLASS No.	TITLE 11形回転形エンコーダ規格書 11mm Size Rotary Encoder Specification
-----------	---

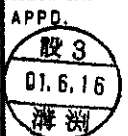
項目 Item	条件 Conditions	規格 Specifications
4-2 分解能 Resolution	1回転にて出力されるパルス数 Number of pulses in 360° rotation.	各相 15パルス/360° 15 pulses/360° for each phase (2クリック 1パルス) (2Click 1Pulse)
4-3 スイッチング特性 Switching characteristics	<p>下記測定回路<fig. 2>を用い、回転軸を$360^\circ \cdot s^{-1}$の速さで回転し測定する。 Measurement shall be made under the condition as follows.</p> <p>1) Shaft rotational speed : $360^\circ \cdot s^{-1}$ 2) Test circuit : <fig. 2></p>  <p><fig. 2> 5kΩ 5kΩ D.C. 5V A端子 Terminal A B端子 Terminal B エンコーダ部 Encoder C端子 Terminal C</p> <p>(注記) コードOFF状態 : 出力電圧が3.5V以上の状態を言う。 コードON状態 : 出力電圧が1.5V以下の状態を言う。 (note) Code-OFF area : The area which the voltage is 3.5V or more. code-ON area : The area which the voltage is 1.5V or less.</p>	 <p><fig. 3> OFF 3.5V 1.5V ON t_1 t_2 t_3</p>
1) チャタリング Chattering	コードのOFF→ON及びON→OFFの際の、出力1.5V~3.5Vの通過時間にて規定する。 Specified by the signal's passage time from 3.5V to 1.5V or from 1.5V to 3.5V of each switching position (code OFF→ON or ON→OFF).	$t_1, t_3 \leq 2ms.$
2) 振動ノイズ (バウンス) Sliding noise (Bounce)	コードONの部分の1.5V以上の電圧変動時間とし、チャタリング t_1, t_3 両者との間1ms.以上の1.5V以下のON部分を有するものとする。また、振動ノイズ間1.5V以下の範囲が1ms.ある場合は、別の振動ノイズと判断する。 Specified by the time of voltage change exceed 1.5V in code-ON area. When the bounce has code-ON time less than 1ms. between chatterings (t_1 or t_3), the voltage change shall be regarded as a part of chattering. When the code-ON time between 2 bounces is less than 1ms., they are regarded as 1 linked bounce.	$t_2 \leq 2ms.$
3) 振動ノイズ Sliding noise	コードOFFの部分の電圧変動 The voltage change in code-OFF area.	3.5V以上 3.5V min.

					 ALPS ELECTRIC CO., LTD.			
SYMB	DATE	APPD	CHKD	DSGD	APPD.	CHKD	DSGD	TITLE
								11形回転形エンコーダ 11mm Size Rotary encoder
								DOCUMENT NO.
								5LA211-49 (2/5)

CLASS NO.	TITLE 11形回転形エンコーダ規格書 11mm Size Rotary Encoder Specification	
項目 Item	条件 Conditions	規格 Specifications
4-4 位相差 Phase-difference	<p>360°・s⁻¹の定速にて操作軸を回転する。 Measurement shall be made under the condition which the shaft is rotated in 360°・s⁻¹ (constant speed).</p> <p><fig. 4></p> <p>注意事項 接点動作点ですので手動操作時の出力波形はご使用されるツマミ巻、軸の回転速度によって変化致します。回路設計時は実機にて確認願います。 Note: Above specification (4-4) is changeable. When operate by manual. Please check performance using actual circuit and knob.</p>	<p><fig. 4>において ΔT≥6ms. In<fig. 4></p>
4-5 絶縁抵抗 Insulation resistance	<p>端子-軸受間D. C. 250V1mA印加する。 Measurement shall be made under the condition which a voltage of 250V D. C. 1mA is applied between individual terminals and bushing.</p>	<p>端子-軸受間にて100MΩ以上 Between individual terminals and bushing: 100MΩ MIN.</p>
4-6 耐電圧 Dielectric strength	<p>端子-軸受間A. C. 300V1分間又は、A. C. 360V2秒間印加する。(リーク電流1mA) A voltage of 300V A. C. shall be applied for 1min or a voltage of 360V A. C. shall be applied for 2sec between individual terminals and bushing. (Leak current:1mA)</p>	<p>損傷・アーク・絶縁破壊がないこと。 Without damage to parts arcing or breakdown.</p>

5. 機械的性能 Mechanical characteristics

項目 Item	条件 Conditions	規格 Specifications
5-1 全回転角度 Total rotational angle		360° (エンドレス) 360° (Endless)
5-2 クリックトルク Detent torque	回転速度は60°/1秒 Rotational speed 60°/sec.	18±8mN・m
5-3 クリック点数及び位置 Number and position of detents.		30点クリック 30 detents (ステップ角度 12°±3°) (Step angle:12°±3°)
5-4 端子強度 Terminal strength	端子先端の任意の方向に5Nの力を1分間加える。 A static load of 5N be applied to the tip of terminals for 1minute in any direction.	端子の破壊、著しい力'タがないこと。但し、端子の曲がりは可とする。 Without damage or excessive looseness of terminals. Terminal bend is permitted.
5-5 軸の押し引き強度 Push-pull strength of shaft	軸の押し及び引き方向に100Nの力を10秒間加える。(セット実装状態) Push and pull static load of 100N shall be applied to the shaft in the axial direction for 10s. (After installing)	軸の破壊、著しいガタのないこと。番線に異常がないこと。 Without damage or excessive play in shaft. No excessive abnormality in rotational feeling.

					ALPS ELECTRIC CO., LTD.	
		APPD. 設3 01.6.16 溝淵	CHKD. 設3 01.6.16 木村	DSGD. 設3 01.6.16 山口	TITLE 11形回転形エンコーダ 11mm Size Rotary encoder	
SYMB	DATE	APPD	CHKD	DSGD	DOCUMENT NO.	5LA211-49 (3/5)

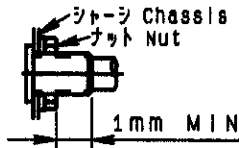
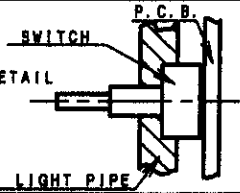
CLASS No.	TITLE 回転形エンコーダ 規格書 ROTATIONAL ENCODER SPECIFICATION		(SW01)
項目 Item	条件 Conditions	規格 Specifications	
5-6 軸受ネジ締付強度 Bushing nut tightening strength	(ネジ 付きのみ適用) (Applied for with-thread type) <fig. 5>を満足するように締付る。 Tighten the nut according to <fig. 5>	 1N・m以下 にて使用のこと。 Tightening torque to be no greater than 1N・m.	
5-7 軸ガタ Shaft wobble	軸先端から5mmの位置に50mN・mの曲げモーメントを加える。 A momentary load of 50mN・m shall be applied at the point 5mm from the tip of the shaft in a direction perpendicular to the axis of shaft.	軸受長 Bushing length (mm)	軸力'タ Wobble 以下 (mmp-d less)
5-8 軸のスラスト方向ガタ Shaft play in axial direction		3.5	1.4xL/30
5-9 軸の回転方向力'タ Rotation play at the click position	角度板にて測定する。 Measure with jig for rotational angle.	5	1.1xL/30
5-10 はんだ耐熱 Resistance to soldering heat	7項の「はんだ付け条件」による。 Specified by the clause 7 "Soldering conditions".	7	0.7xL/30
5-11 取付け上の注意 Notice for mounting	右図の様にスイッチ本体を挿えてご使用下さい。セット側でスイッチ本体の引き 及び回転方向の力'イト'が無い場合は、はんだ付けだけの固定となり、はんだ付け信頼性 及びスイッチ本体強度が不安定となる可能性があります。 Hold the bushing use front panel or light pipe. Because this switch not has thread. If don't hold the bushing, the switch maybe become intermittent or rough mounting after soldering by knob stopper face.	10	0.5xL/30
		 Lは取付長さで比例計算する。 L: Measurement point from mounting surface of bushing.	

6. 耐久性能 Endurance characteristics.

項目 Item	条件 Conditions	規格 Specifications
6-1 シフト寿命性能 Rotational life	無負荷で軸を毎時500サイクルの速さで、15,000サイクル断続動作を行う。 但し、試験途中5,000で中間測定を行う。(1サイクルは、360°1往復) The shaft of encoder shall be rotated to 15,000 cycles at a speed of 500cycles per hour without electrical load. after which measurements shall be made. However, an interim measurement shall be made immediately after 5,000 cycles. (1 cycle: rotate 360° CCW rotate 360° CW)	クリックトルク: 初期規格値に対し+30% その他、初期規格を満足すること。 Detent torque: Relative to the previously specified value. +30% Except above items, specification in clause 4.1~6 and 5.1, 5.3 shall be satisfied.

 ALPS ELECTRIC CO., LTD.				
APPR 設 2 03.10.30 溝 潤	CHKD 設 2 03.10.30 野 村	DSGD 設 2 03.10.22 末 村	TITLE ROTATIONAL ENCODER 回転形エンコーダ	DOCUMENT NO. 5LA211-49 (4/5)
初 設	2001-06-16	溝 潤	末 村	
SYMS	DATE	APPD	CHKD	DSGD

CLASS No.	TITLE 11形回転形エンコーダ規格書 11mm Size Rotary Encoder Specification
-----------	---

7. はんだ付け条件 Soldering conditions (SW01), (SW02)

7-1 手はんだの場合 Manual soldering

△ 350
 温度 ~~300~~ °C 以下、時間 3 秒以内 △ 350
 Bit temperature of soldering iron : ~~300~~ °C or less.
 Application time of soldering iron : within 3s.

7-2 ディップはんだの場合 Dip soldering

使用基板 : t1.6両面銅張紙基板
 Printed wiring board: Both-sided copper clad laminate board with thickness of 1.6mm.

フラックス : 比重 0.82 以上のフラックスを用い発泡式フラクサーにて発泡面高さ、基板厚の 3 分の 2。
 Flux:

- Specific gravity: 0.82 or more.
- Flux shall be applied to the board using a bubble foaming type fluxer.
- The board shall be soaked in the flux bubble only to the 2/3 of its thickness.

プリヒート : 基板表面温度 100 °C 以下、時間 2 分以内
 Preheating:
 ・Surface temperature of board: 100 °C or less.
 ・Preheating time: within 2 min.

はんだ : 温度 260 ± 5 °C、時間 5 ± 1 秒
 Soldering:
 ・Solder temperature: 260 ± 5 °C.
 ・Immersion time: 5 ± 1 s.

以上の工程を 1 回または 2 回通過する。
 Apply the above soldering process for 1 or 2 times.

					ALPS ELECTRIC CO., LTD.			
					APPD 設 3 01.6.16 溝 潤	CHKD 設 3 01.6.16 木 村	DSGD 設 3 01.6.16 山 口	TITLE 11形回転形エンコーダ 11mm Size Rotary encoder
△	2004-3-3	相 沢	—	木 村				DOCUMENT NO. 5LA211-49 (5/5)
SYMB	DATE	APPD	CHKD	DSGD				

OR

CLASS No.	TITLE プッシュモーメントリスイッチ規格書 PUSH MOMENTARY SWITCH SPECIFICATION	(SW02)
-----------	---	--------

1. 定格容量 (抵抗負荷) D. C. 16V3A (10mA MIN)
Switch rating (Resistor load)

2. 電気的性能 Electrical characteristics

項目 Item	条件 Conditions	規格 Specifications
2-1 接触抵抗 Contact resistance	D. C. 5V10mA電圧降下法にて測定する。 Measured by the 10mA 5V D.C. voltage drop method.	100mA MAX.
2-2 チャタリング Chattering	1サイクル (OFF-ON-OFF) 1秒で動作させる。 Switch is operated at the rate of 1 cycle 1 sec. The 1 cycle shall be OFF-ON-OFF.	10msec以下 Less than 10msec
2-3 絶縁抵抗 Insulation resistance	端子-軸受間D. C. 250V1mA印加する。 Measurement shall be made under the condition which a voltage of 250VD. C. 1mA is applied between individual terminals and bushing.	端子-軸受間にて100MΩ以上 Between individual terminals and bushing: 100Ma MIN.
2-4 耐電圧 Dielectric strength	端子-軸受間D. C. 300V1分間又は、A. C. 360V2秒間印加する。(リーク電流1mA) A voltage of 300VA. C. shall be applied for 1min or a voltage of 360VA. C. shall be applied for 2sec between individual terminals and bushing. (Leak current:1mA)	漏電・アーク・絶縁破壊がないこと。 Without damage to parts arcing or breakdown.

注記: 軸・スイッチ端子間は絶縁されています。
Note: Shaft is insulated from switch terminal.

3. 機械的性能 Mechanical characteristics

項目 Item	条件 Conditions	規格 Specifications
3-1 スイッチ回路・接点数 Contact arrangement		単発単接 (Push on) S. P. S. T. (Push on)
3-2 スイッチ行程量 Switching stroke		1.5±0.5mm
3-3 スイッチ作動力 Switch operation force		5±2N

4. 耐久性能 Endurance characteristics.

項目 Item	条件 Conditions	規格 Specifications
4-1 動作寿命特性 Operating life	定格負荷にて軸を毎時500回の速さで20,000回連続動作を行う。 但し、試験途中5,000で中間測定を行う。 The shaft of switch shall be with electrical load. at a speed of 500times per hour with electrical load. after which measurements shall be made. However, an interim measurement shall be made immediately after 5,000 times.	接触抵抗: 200mA以下 その他、換算規格を満足すること。 Switch contact resistance: 200mA MAX. Except above items, specifications in clause 2.2~4. and 3.1~3 shall be satisfied.

SYMB	DATE	APPD	CHKD	DSGD
		1枚-1G 991116 玉田	1枚-1G 991115 斎藤	TITLE PUSH MOMENTARY SWITCH プッシュモーメントリスイッチ DOCUMENT NO. 5LA2114-5 (/)

OR

注記 軸受材質：亜鉛ダイキャスト 軸材質：アルミニウム
 NOTES BUSHING MATERIAL: ZINC ALLOY DIE CASTING
 SHAFT MATERIAL: ALUMINUM

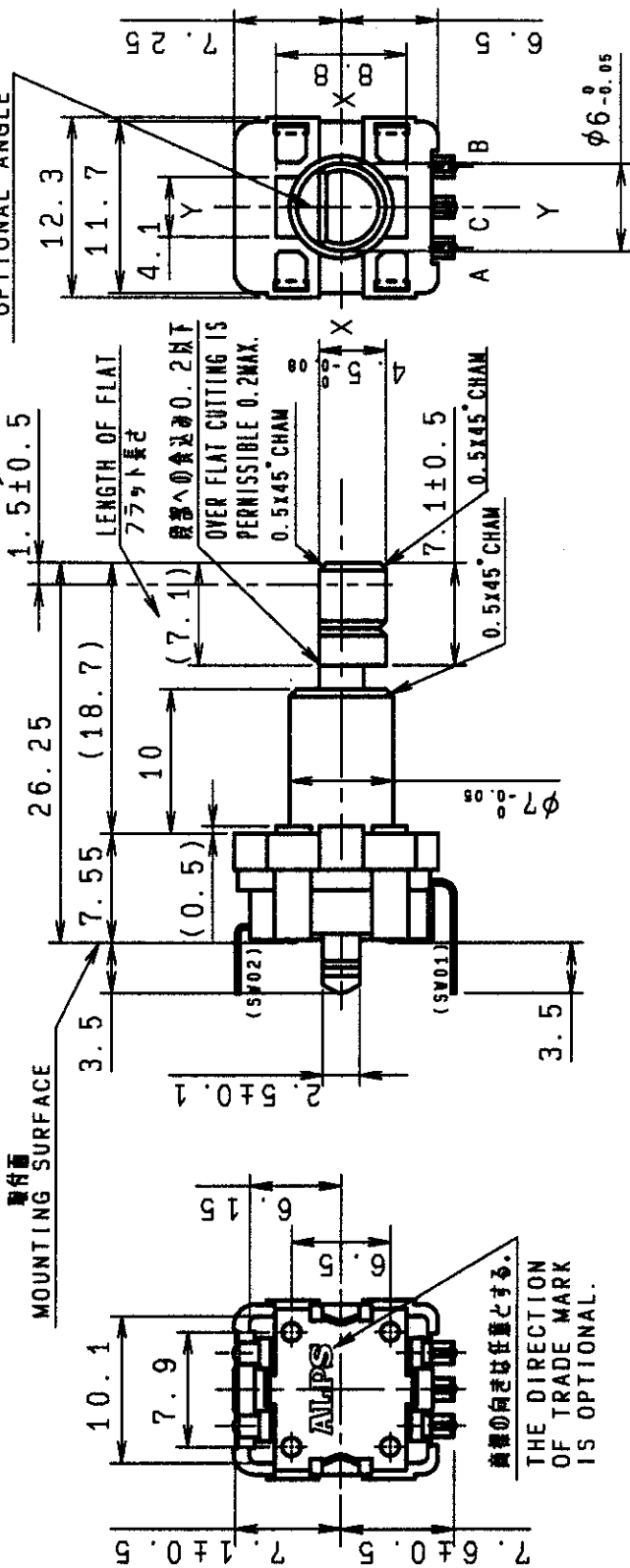

軸受部詳細図 (SHAFT DETAIL)

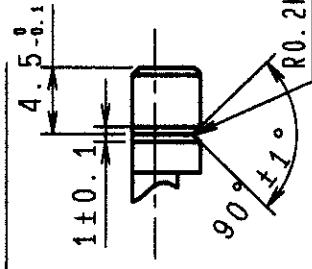

取付穴寸法図 許容±0.1 (挿入側より)
 P.W.B. MOUNTING DETAIL TOLERANCE±0.1
 VIEWED FROM MOUNTING SIDE

基板厚 t=1.6mm
 P.C.B.

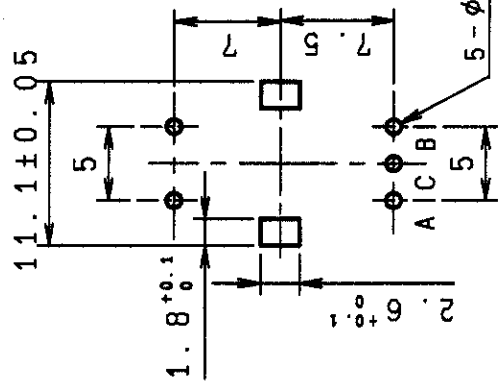

指定なき部分の許容差 (TOLERANCES UNLESS OTHERWISE SPEC.)	
L	±0.3
10 L	±0.5
100 L	±0.8
角度 (ANGULAR DIMENSION)	±5°

PART NO.				NAME				MATERIAL NAME / CODE				FINISH				15747, 307リット							
ALPS ELECTRIC CO., LTD.																							
DSGD.				H. KIMURA				2003-11-12				SCALE 2:1											
CHKD.												TITLE 11号1軸 PUSH ON SW 薄型Iコ-ダ-											
APPD.				S. AIZAWA				2004-1-9				UNIT III III											
SYMB				DATE				APPD				CHKD				DSGD				DOCUMENT NO. LA211439L			