

# 深圳市金航标电子有限公司

## 产品技术规格书 SPECIFICATION

产品型号 PART NO:      KH3216-G8
客户料号 CUSTOMER PART NO:
客户确认 CUSTOMER APPROVED BY:
确认日期 APPROVED DATE:

RoHS Compliant Parts

深圳市龙华区民治大道1079号展滔科技大厦C座C809室

TEL: 0755-83044319    FAX: 0755-83975897

拟制 Prepared by:	审核 Checked by :	批准 Approved by:
送样日期 Formed On	产品版本 Document Version ( V1.2 )	

## 目 录

### Table of contents

规格书版本更改记录 Version rejigger track record	3
1. 概述 Introduction	4
2. 外型尺寸及测试板焊盘尺寸 Dimensions	4~5
3. 测试电路和匹配电路 Evaluation Board and Matching Circuits	5
4. 电气性能 Electrical Characteristics	6
5. 特性曲线 Characteristic curve	6
6. 方向图 Radiation Pattern	7~8
7. 可靠性试验 Dependability Test	9~10
8. 回流焊温度 Reflow Soldering Standard Condition	10
9. 包装尺寸 Packaging and Dimensions	11~12

## 产品规格书版本更改记录

### Version rejigger track record

版本号 Version	更改记录 Rejigger	拟制 Prepared	批准 Approve	日期 Date
V1.0 12	首次发行	姚富鑫	贺俊驹	2019/07/
V1.1 05	变更产品包装方向与修正包装带信息	姚富鑫	贺俊驹	2019/09/
V1.2 09	变更产品一盘的包装数量为 6K pcs	姚富鑫	贺俊驹	2019/09/
备注： 1、更改产品电性能指标时，版本号需更换（V1.0 换为 V2.0、V3.0……）； 2、更改产品测试方法（包括可靠性测试条件），或更改使用条件时，当前版本号加系列（V1.0 换为 V1.1、V1.2……）。				

## 1. 概述 INTRODUCTION

金航标微波多层陶瓷天线 LA 系列产品设计用于 WLAN、Wi-Fi、蓝牙、PHS，手机多频天线, FM 等小体积 SMD 片式设计。

**kinghelm** Microwave Multi-Layer Ceramic Antenna LA series are designed to be used in WLAN、Wi-Fi、Bluetooth、PHS、 Multiple-band Mobile phone antenna, FM, etc and compact size SMD chip design.

## 2. 外型尺寸 Dimensions (Unit: mm)

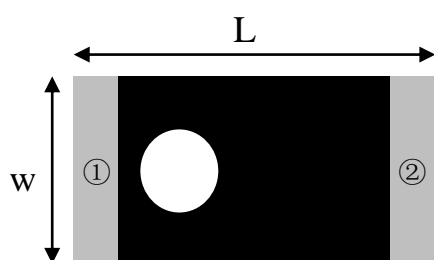

( Top View )

Number	Terminal Name
①	INPUT
②	NC

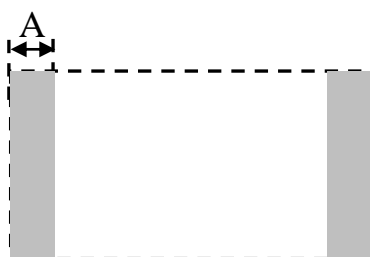

( Bottom View )



( Side View )

Symbols	L	W	T	A
Dimensions	3.2+/-0.2	1.6+/-0.2	0.5+/-0.1	0.4+/-0.1

## 3. 测试电路和匹配电路 Evaluation Board and Matching Circuits

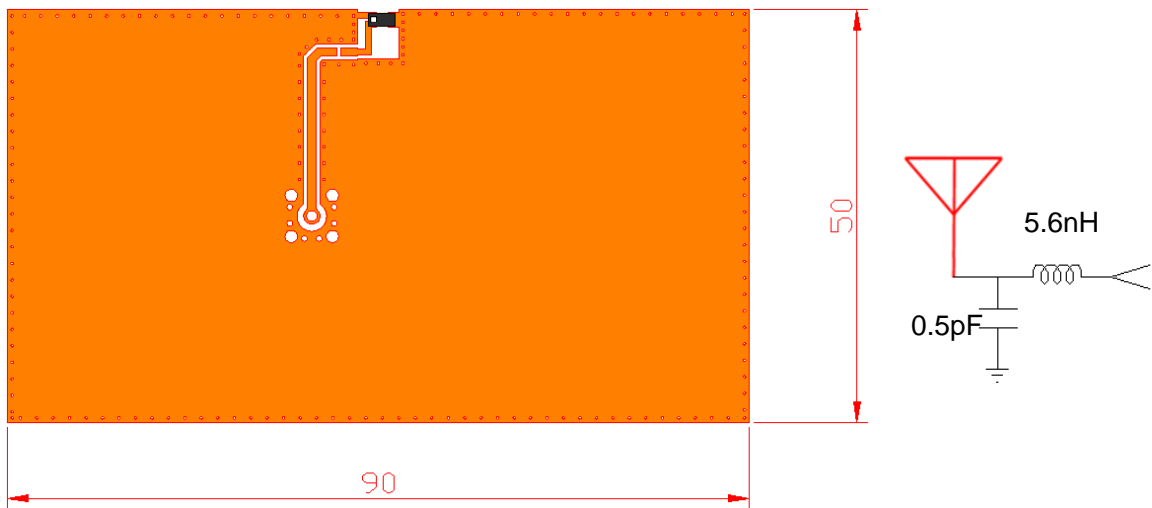
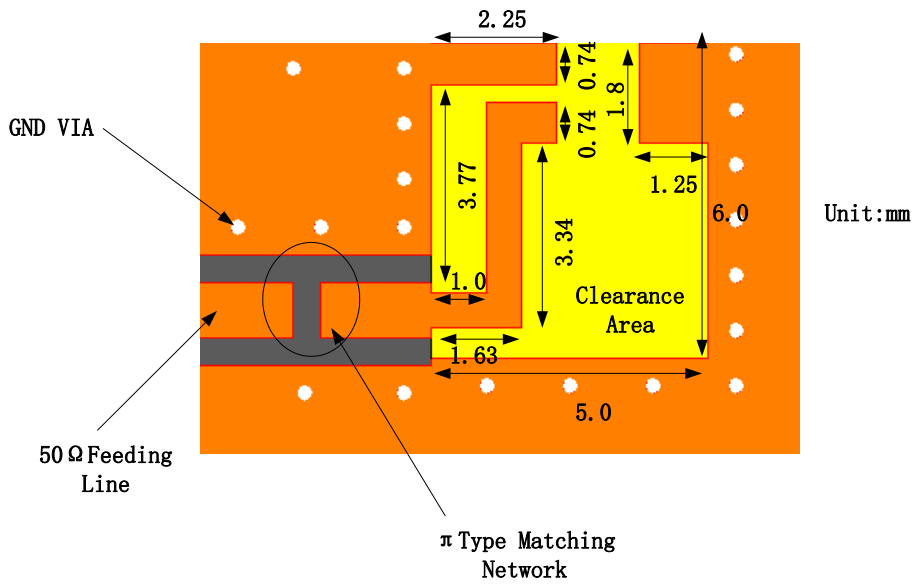

## 4. 电气性能 Electrical Characteristics

No.	Item (项目)	Specifications (特性)
4.1	Central Frequency 中心频率	2545MHz
4.2	Band Width 通带宽度	100 MHz typ.
4.3	Peak Gain 峰值增益	5.54 dBi
4.4	Return Loss 回波损耗	≤2.0
4.5	Polarization 极化方式	Linear 线性
4.6	Azimuth Beam width 方位角	Omni-directional 全向
4.7	Impedance 阻抗	50 欧姆

## 5. 特性曲线 Characteristic curve

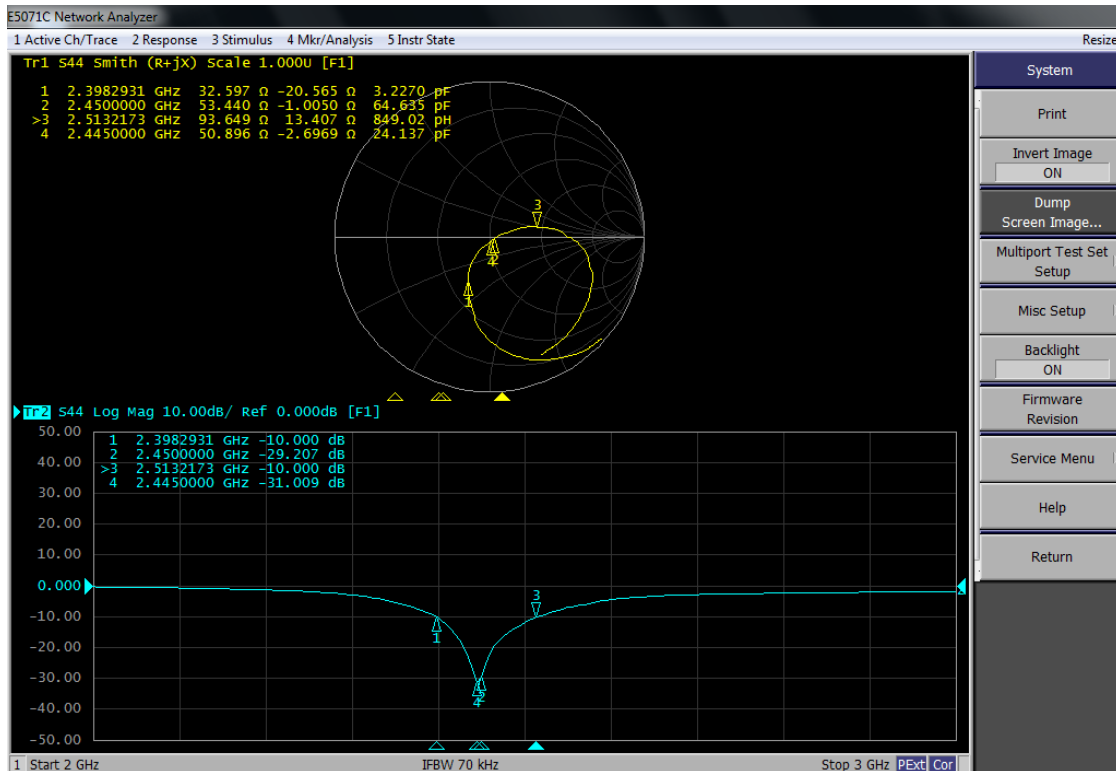

## 6. 方向图 Radiation Pattern

coordinates:

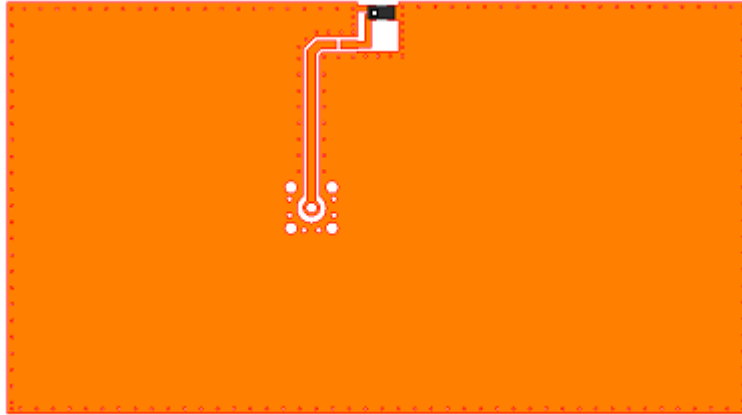
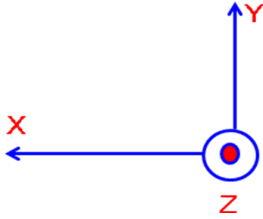

### X-Z Plane

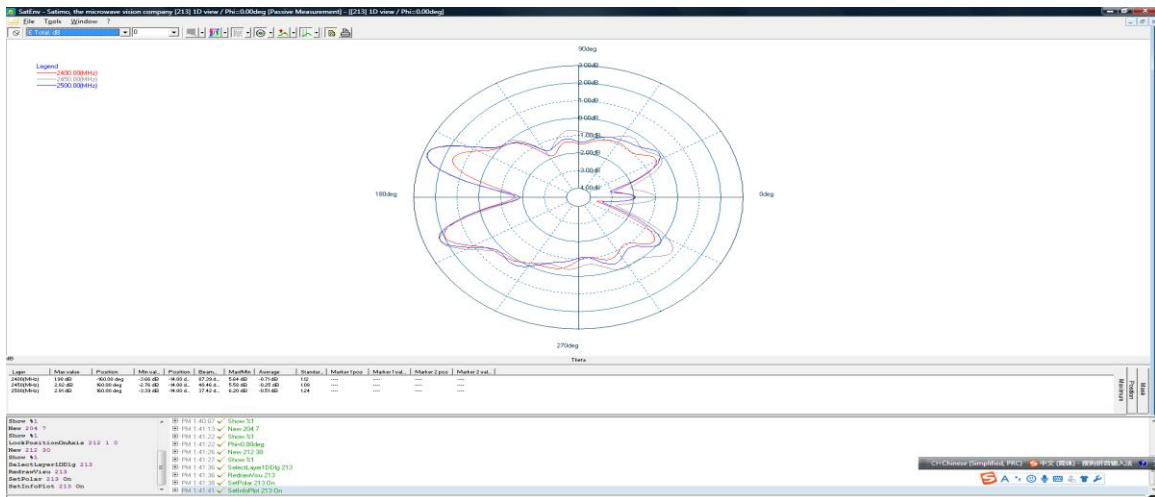

### X-Y Plane

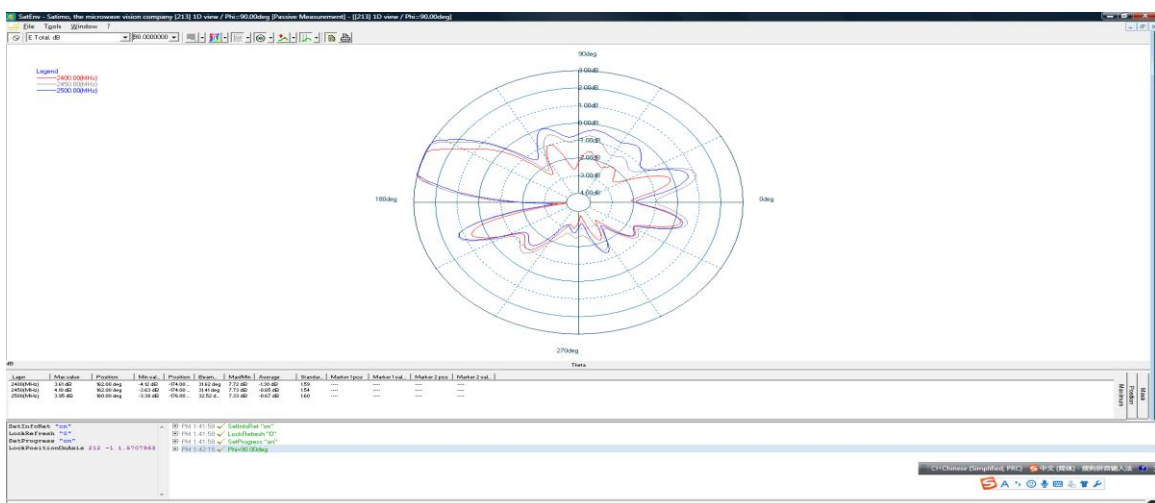

## Y-Z Plane

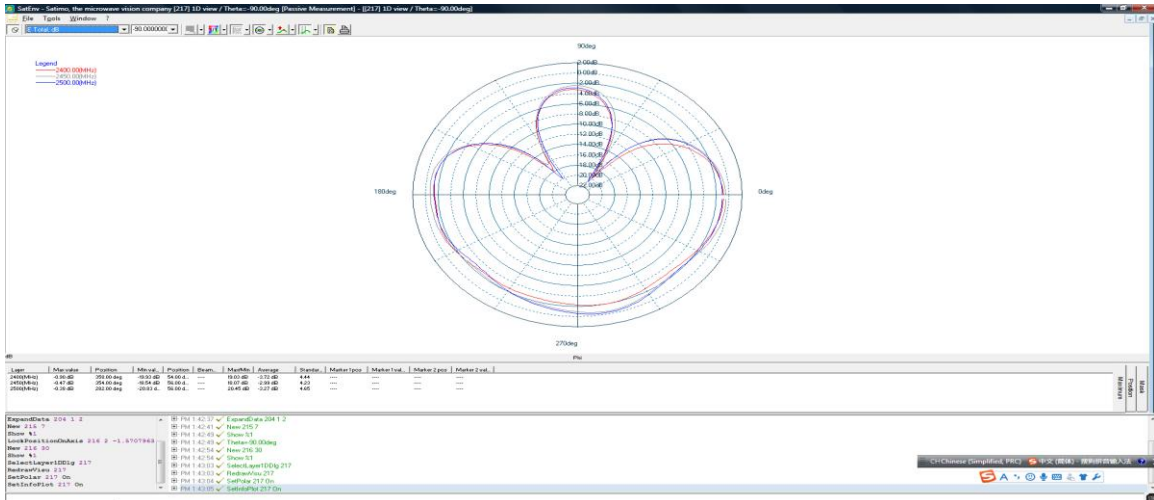

## 3D Radiation Pattern

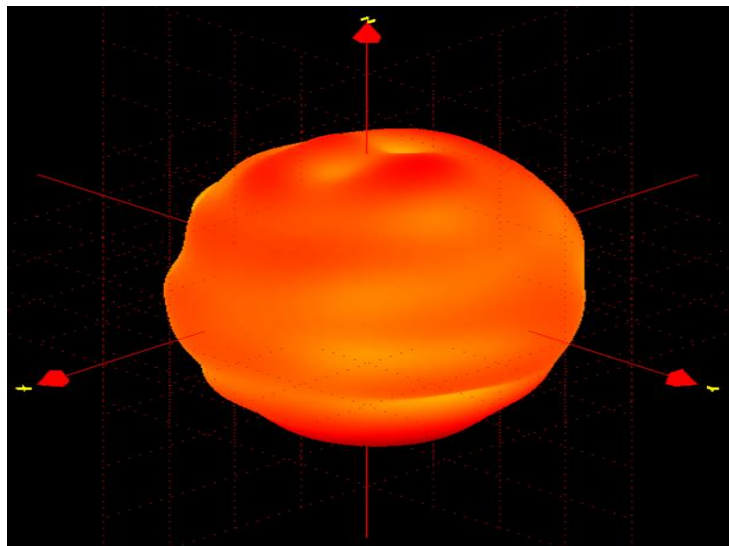

Frequency (MHz)	2400	2450	2500
Avg. Gain (dBi)	-1.91	-1.30	-1.48
Peak Gain (dBi)	1.76	4.08	2.53
Efficiency (%)	72.1	78.2	71.8



## 7 可靠性试验 Dependability Test

基准条件: 温度范围 Temperature range	25±5°C
相对湿度范围 Relative Humidity range	55~75%RH
工作温度 Operating Temperature range	-40°C~+85°C
贮藏温度 Storage Temperature range	-40°C~+85°C

### 7.1 耐振动 Vibration Resist

在振动频率为 10~55Hz 振幅为 1.5mm 沿 X.Y.Z 方向各振动 2 小时后测试需符合电气性能指标。

The device should fulfill the electrical specification after applied to the vibration of 10 to 55Hz with amplitude of 1.5mm for 2 hours each in X, Y and Z directions.

### 7.2 耐跌落冲击 Drop Shock

在 100cm 高度处按 X, Y, Z 三个面分别自由跌落在木制地板上共 3 次后, 要求无机械损伤。

The device should have no mechanical damage after dropping onto the hard wooden board from the height of 100cm for 3 times each facet of the 3 dimensions of the device.

### 7.3 耐焊接热 Solder Heat Proof

能承受经 120~150°C 的温度预热 120 秒后, 在 255°C+10°C 的焊锡浸 5±0.5 秒, 或 300°C-10°C 的电烙铁焊接 3±0.5 秒, 焊接面无损伤。

The device should be satisfied after preheating at 120°C~150°C for 120 seconds and dipping in soldering Sn at 255°C+10°C for 5±0.5 seconds, or electric iron 300°C-10°C for 3±0.5 seconds, without damage.

### 7.4 推力试验 Adhesive Strength of Termination

在产品电极端子上或表面上可承受 5N(≤0603); 10N(>0603) 水平推力 10±1 秒而无明显外观损坏与电极移位。

The device have no remarkable damage or removal of the termination after horizontal force of 5N(≤0603); 10N(>0603)with 10±1 seconds.

### 7.5 耐弯曲试验 Bending Resist Test

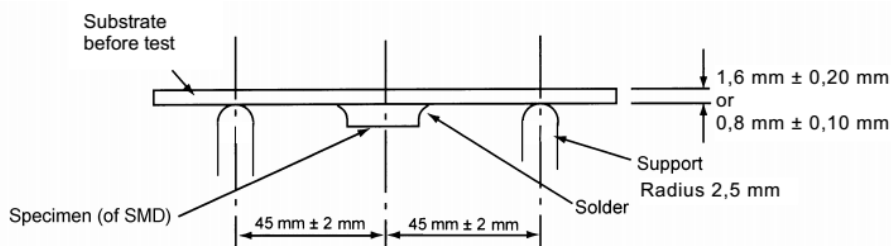

将产品按图焊在 1.6±0.2mm 或 0.8±0.1mm 的 PCB 板中间, 由箭头方向施力: 1mm/S, 弯曲距离: 1.5mm, 保持 5±1S, 产品金属层无脱落。

Weld the product to the center part of the PCB with the thickness 1.6±0.2mm or 0.8±0.1mm as the illustration shows, and keep exerting force arrow-ward on it at speed of :1mm/S, and hold for 5±1S at the position of 1.5mm bending distance, so far, any peeling off of the product metal coating should not be detected.

## 7.6 耐湿热特性 Moisture Proof

在温度为  $60 \pm 2^\circ\text{C}$ ，相对湿度 90~95% 的恒温湿箱中放置 96 小时，在常温中恢复 1~2 小时后测试，测试需符合电气性能指标。

The device should fulfill the electrical specification after exposed to the temperature  $60 \pm 2^\circ\text{C}$  and the relative humidity 90~95% RH for 96 hours and 1~2 hours recovery time under normal condition.

## 7.7 高温特性 High Temperature Endurance

在温度为  $85 \pm 5^\circ\text{C}$  的恒温箱中放置  $96 \pm 2$  小时，在常温中恢复 1~2 小时后测试。测试需符合电气性能指标。

The device should fulfill the electrical specification after exposed to temperature  $85 \pm 5^\circ\text{C}$  for  $96 \pm 2$  hours and 1~2 hours recovery time under normal temperature.

## 7.8 低温特性 Low Temperature Endurance

在温度为  $-40^\circ\text{C} \pm 5^\circ\text{C}$  低温箱中放置  $96 \pm 2$  小时后恢复 1~2 小时，测试需符合电气性能指标。

The device should fulfill the electrical specification after exposed to the temperature  $-40^\circ\text{C} \pm 5^\circ\text{C}$  for  $96 \pm 2$  hours and to 2 hours recovery time under normal temperature.

## 7.9 温度循环 Temperature Cycle Test

在  $-40^\circ\text{C}$  温度中保持 30 分钟，再在  $+85^\circ\text{C}$  温度中保持 30 分钟，共循环 5 次后在常温中恢复 1~2 小时后测试需符合电气性能指标。

The device should fulfill the electrical specification after exposed to the low temperature  $-40^\circ\text{C}$  and high temperature  $+85^\circ\text{C}$  for  $30 \pm 2$  min each by 5 cycles and 1 to 2 hours recovery time under normal temperature.

## 8 回流焊温度 Reflow Soldering Standard Condition

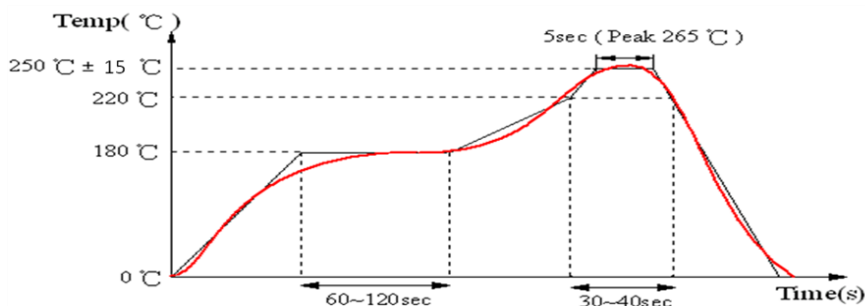

## 9 包装尺寸 (3216) Packaging and Dimensions

### 9.1 Plastic Tape

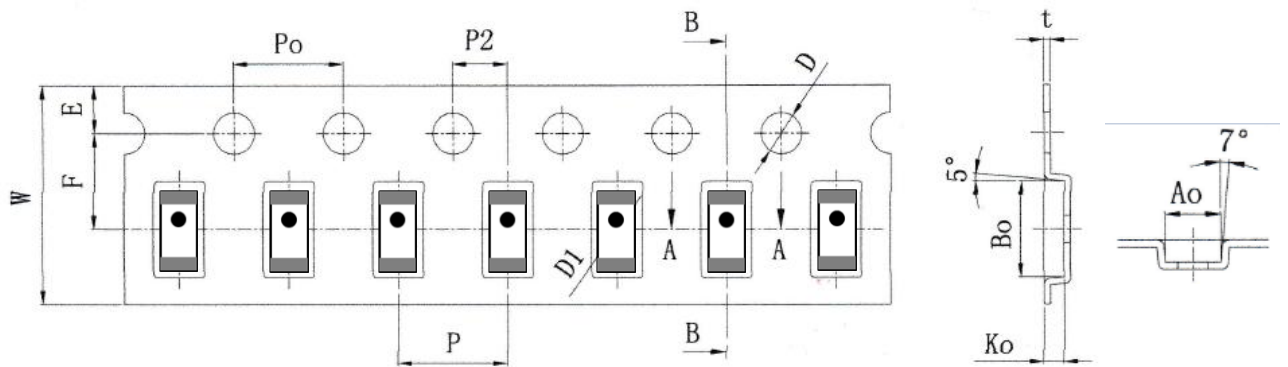

外觀	規格	公差
W	8.00	±0.10
P	4.00	±0.10
E	1.75	±0.10
F	3.50	±0.05
P <sub>2</sub>	2.00	±0.05
D	1.50	+0.10 -0.00
D <sub>1</sub>	1.00	±0.10
P <sub>0</sub>	4.00	±0.10
10P <sub>0</sub>	40.00	±0.20

外觀	規格	公差
A <sub>0</sub>	1.85	±0.10
B <sub>0</sub>	3.50	±0.10
K <sub>0</sub>	0.73	±0.10
t	0.23	±0.05

#### 包装说明: Remarks for Package

载带尾部空穴长度 150~200mm, 载带头部空穴长度 250~300mm, 头部的盖带加长 250mm。

Reserve a length of 150~200mm for the trailer of the carrier and 250~300 mm for the leader of the carrier and further 250mm of cover tape at the leading part of the carrier.

### 9.2 Reel (6000 pcs/Reel)

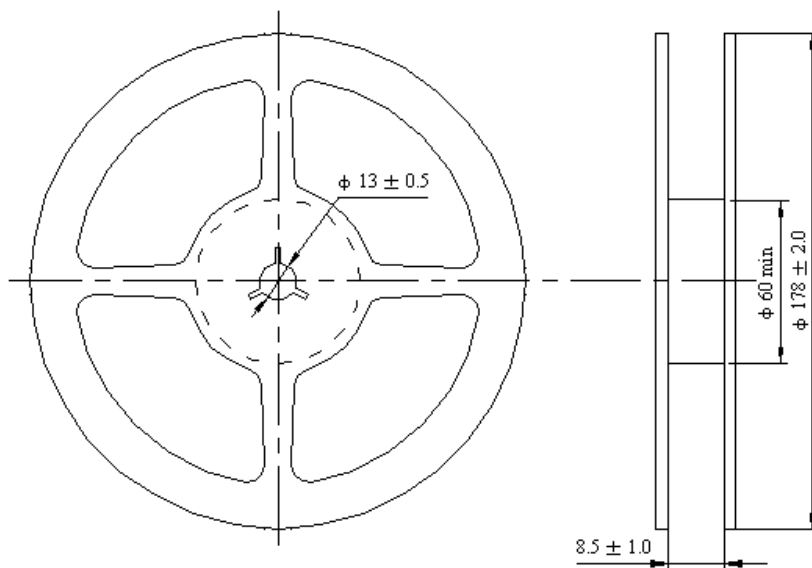

## 9.3 储存条件 Storage Period

产品收到后半年内使用完毕.

Product should be used within six months of receipt.

湿敏等级 1 / 储存温度与湿度:

MSL 1 / Storage Temperature Range : <30 degree C, Humidity : <85%RH