

承認書

Specification For Approval

Customer: (客戶)

Description: (產品描述) SMDLED1615

Part number: (產品型號) TJ-S1615RGB06A18HQYJYL8-A3

Date: (日期)

Approved By: (客戶承認)

--

Prepared By: (我司承認)

Approval	Check	Design	Sales
----------	-------	--------	-------

核准

審核

製作

業務

Customer Service Hotline: **400-676-8616**

TEL: 0769-8662 5999 0769-8200 2226

E-MAIL : dg@togialed.com

FAX: 0769-8200 2227

WEB: www.togialed.com

Features

- 1.6mm × 1.5mm SMD LED, 0.6mm thickness
- Low power consumption
- Wide view angle
- Package: 4000pcs/reel
- RoHS Compliant

Applications

- Ideal for back light and indicator
- Various colors and lens types available

Package outlines

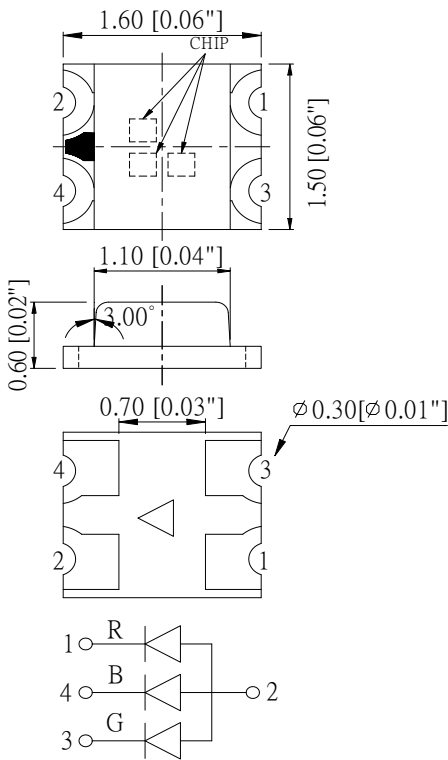

Recommend Pad Layout

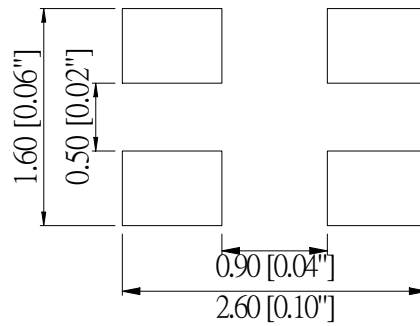

Part No.	Emitted color	Dice Material	Lens color
TJ-S1615RGB06A18HQYJYL8-A3	Red	AlGaInP	Water transparent
	Green	InGaN/GaN	
	Blue	InGaN/GaN	

Notes:

- All dimensions are in millimeters (inches);
- Tolerances are $\pm 0.1\text{mm}$ (0.004inch) unless otherwise noted.

Absolute Maximum Ratings (Ta=25°C)

Parameter	Symbol	Value			Unit
		R	G	B	
Power dissipation	Pd	72	111	111	mW
Forward current	If	30			mA
Reverse voltage	Vr	5			V
Operating temperature	Top	-40 ~+80			°C
Storage temperature	Tstg	-40 ~+85			°C
Peak pulsing current (1/8 duty f=1kHz)	Ifp	125			mA

Electro-Optical Characteristics (Ta=25°C)

Parameter	Test Condition	Symbol	Value			Unit
			Min	Typ	Max	
Wavelength at peak emission	If=20mA	R	--	632	--	nm
		G	--	520	--	
		B	--	465	--	
Spectral half bandwidth	If=20mA	R	--	18	--	nm
		G	--	35	--	
		B	--	25	--	
Dominant wavelength	If=20mA	R	620	--	630	nm
		G	520	--	530	
		B	465	--	475	
Forward voltage	If=20mA	R	1.8	--	2.4	V
		G	2.8	--	3.4	
		B	2.8	--	3.4	
Luminous intensity	If=20mA	R	80	200	--	mcd
		G	400	800	--	
		B	80	200	--	
Viewing angle at 50% Iv	If=10mA	2 θ 1/2	--	120	--	Deg
Reverse current	Vr=5V	Ir	--	--	10	μA

Optical characteristic curves(Red)

Relative Intensity vs. Wavelength

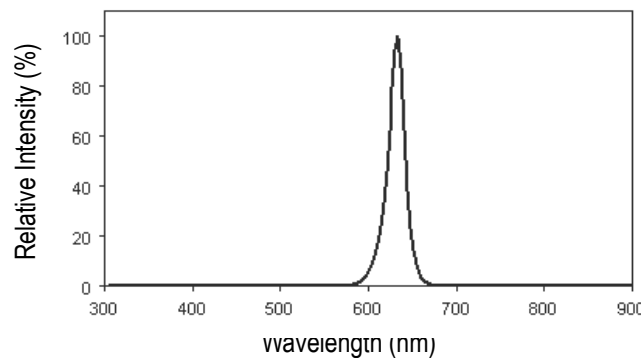

Forward Current vs. Forward Voltage

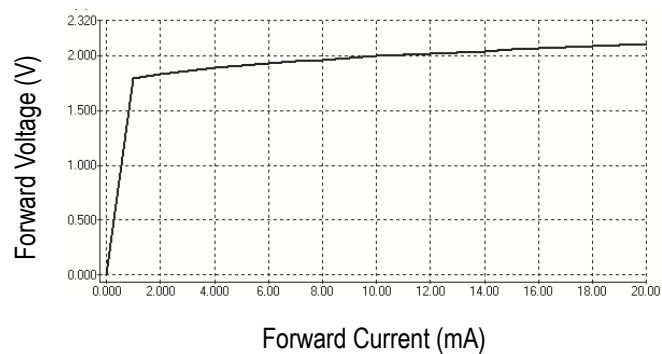

Directive Characteristics

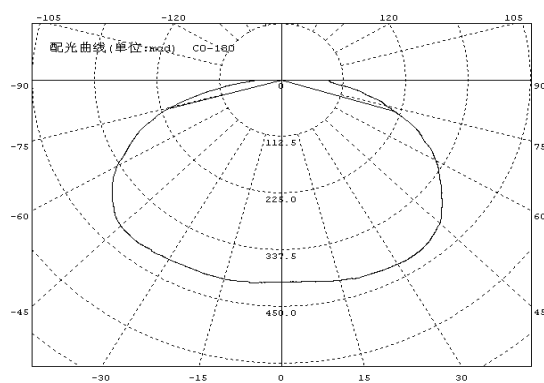

Optical Characteristic Curves (Green)

Relative Intensity vs. Wavelength

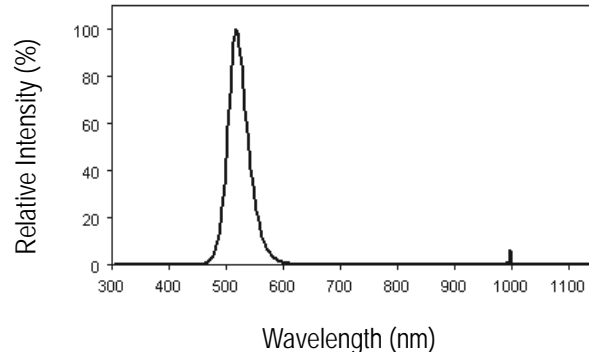

Forward Current vs. Forward Voltage

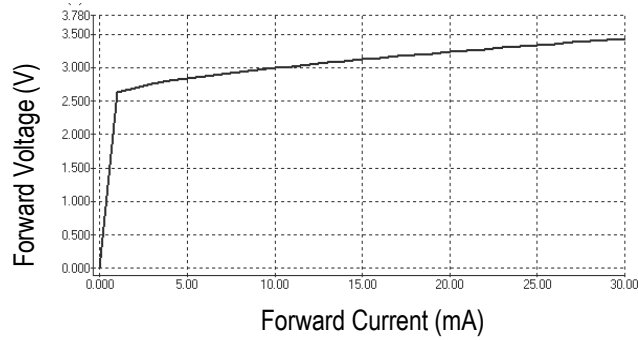

Directive Characteristics

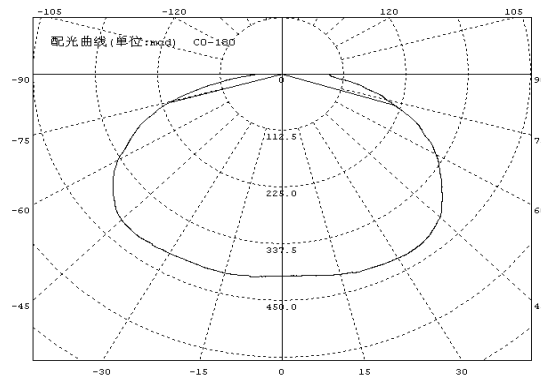

Optical characteristic curves (Blue)

Relative Intensity vs. Wavelength

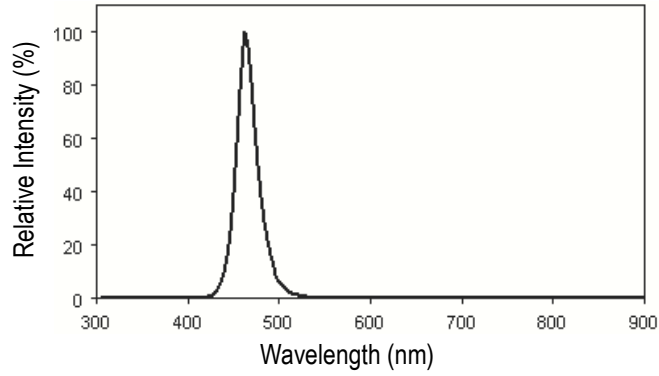

Forward Current vs. Forward Voltage

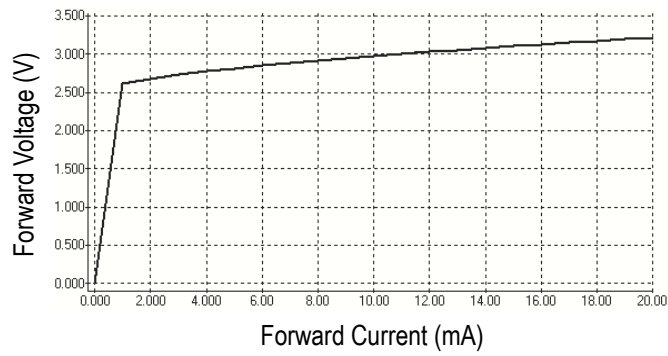

Directive Characteristics

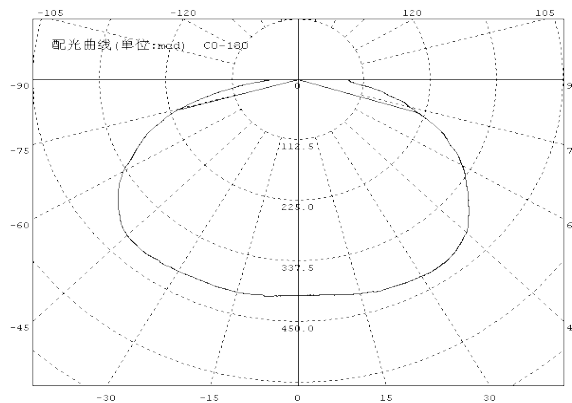

Reflow Profile

■ Reflow Temp/Time

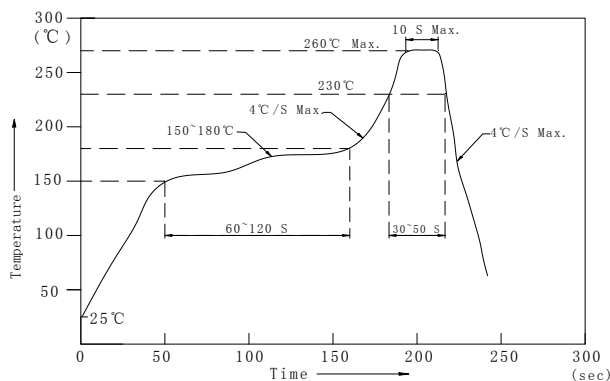

Notes:

1. We recommend the reflow temperature 245°C (±5°C).the maximum soldering temperature should be limited to 260°C.
2. Don't cause stress to the epoxy resin while it is exposed to high temperature.
3. Number of reflow process shall be 2 times or less.

■Soldering iron

Basic spec is $\frac{6}{\lambda}$ 5sec when 320°C (±20°C). If temperature is higher, time should be shorter (+10°C → -1sec).

Power dissipation of iron should be smaller than 20W, and temperatures should be controllable .Surface temperature of the device should be under 350°C.

■Rework

1. Customer must finish rework within 5 sec under 340°C.
2. The head of iron cannot touch copper foil
3. Twin-head type is preferred.

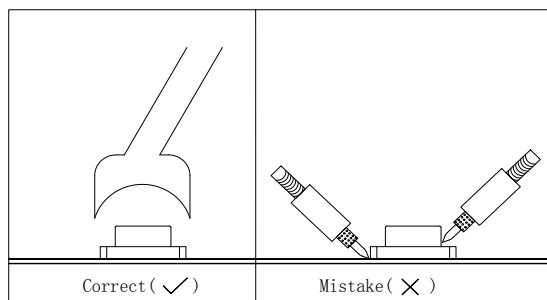

- Avoid rubbing or scraping the resin by any object, during high temperature, for example reflow solder etc.

Test circuit and handling precautions

■ Test circuit

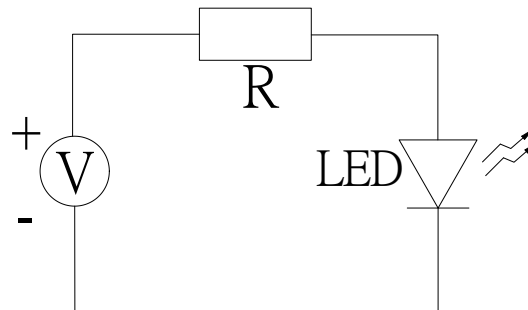

■ Handling precautions

1. Over-current-proof

Customer must apply resistors for protection; otherwise slight voltage shift will cause big current change (Burn out will happen).

2. Storage

2.1 It is recommended to store the products in the following conditions:

Humidity: 60% R.H. Max.

Temperature: 5°C~30°C

2.2 Shelf life in sealed bag: 12 month at <math>< 5^{\circ}\text{C}\sim 30^{\circ}\text{C}</math> and <math>< 30\%</math> R.H. after the package is opened, the products should be used within a week or they should be keeping to stored at $\cong 20$ R.H. with zip-lock sealed.

3. Baking

It is recommended to baking before soldering when the pack is unsealed after 72hrs. The Conditions are as followings:

3.1 $60\pm 3^{\circ}\text{C}$ x (12~24hrs) and <math>< 5\%</math>RH, taped reel type

3.2 $100\pm 3^{\circ}\text{C}$ x (45min~1hr), bulk type

3.3 $130\pm 3^{\circ}\text{C}$ x (15~30min), bulk type

Test Items and Results of Reliability

Test Item	Test Conditions	Standard Test Method	Note	Number of Test
Reflow Soldering	Ta=260±5°C, Time=10±2S	JB/T 10845-2008	3times	0/22
Salt Atmosphere	Ta=35±3°C, PH=6.5~7.2	GB/T 2423.17-2008	24hrs	0/22
Temperature Cycling	-40±5°C 30±1min ↑→(25°C/5±1min)↓ 100±5°C 30±1min	GB/T 2423.22-2012	100cycles	0/22
Thermal Shock	Ta=-40±5°C ~ 100±5°C, 15±1min dwell	GB/T 2423.22-2012	100cycles	0/22
High Humidity High Temp. Cycling	Ta=30±5°C ~ 65±5°C, 90±5%RH, 24hrs/1cycle	GB/T 2423.4-2008	10cycles	0/22
High Humidity High Temp. Storage Life	Ta=85±5°C, ψ(%)=85±5%RH	GB/T 2423.3-2006	1000hrs	0/22
High Temperature Storage Life	Ta=100±5°C, non-operating	GB/T 2423.2-2008	1000hrs	0/22
Low Temperature Storage Life	Ta=-40±5°C, non-operating	GB/T 2423.1-2008	1000hrs	0/22
Life Test	Ta=26±5°C, @20mA, ψ(%)=25%RH ~ 55%RH	--	1000hrs	0/22
High Humidity High Temp. Operating Life	Ta=85±5°C, @20mA, ψ(%)=85%RH	GB/T 2423.3-2006	500hrs	0/22
Low Temperature Operating Life	Ta=-20±5°C, @20mA	GB/T 2423.1-2008	1000hrs	0/22

1615 Series SMD Chip LED Lamps Packaging Specifications

● **Feeding Direction**

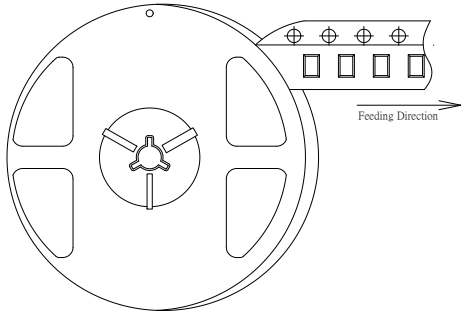

● **Dimensions of Reel (Unit: mm)**

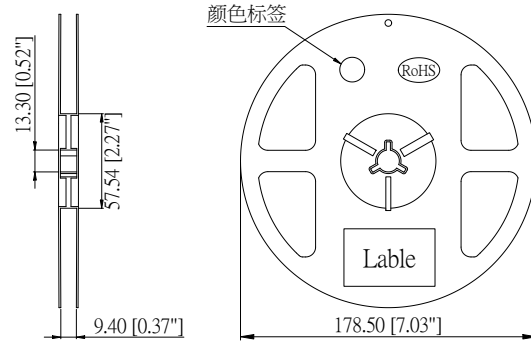

● **Dimensions of Tape (Unit: mm)**

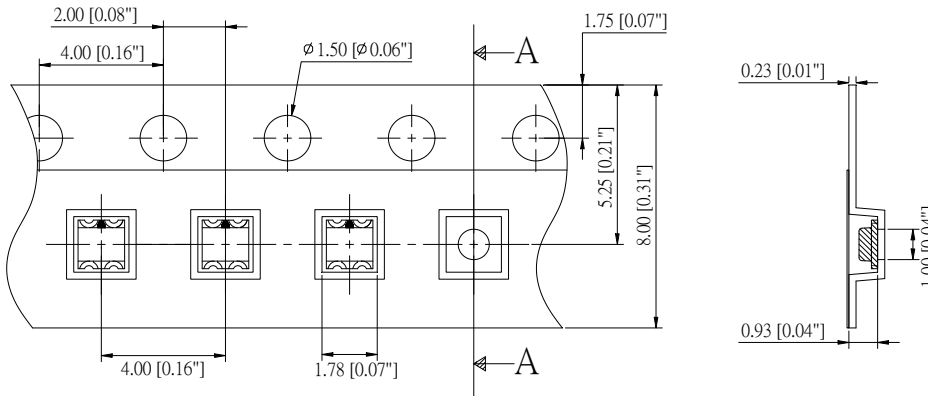

● **Arrangement of Tape**

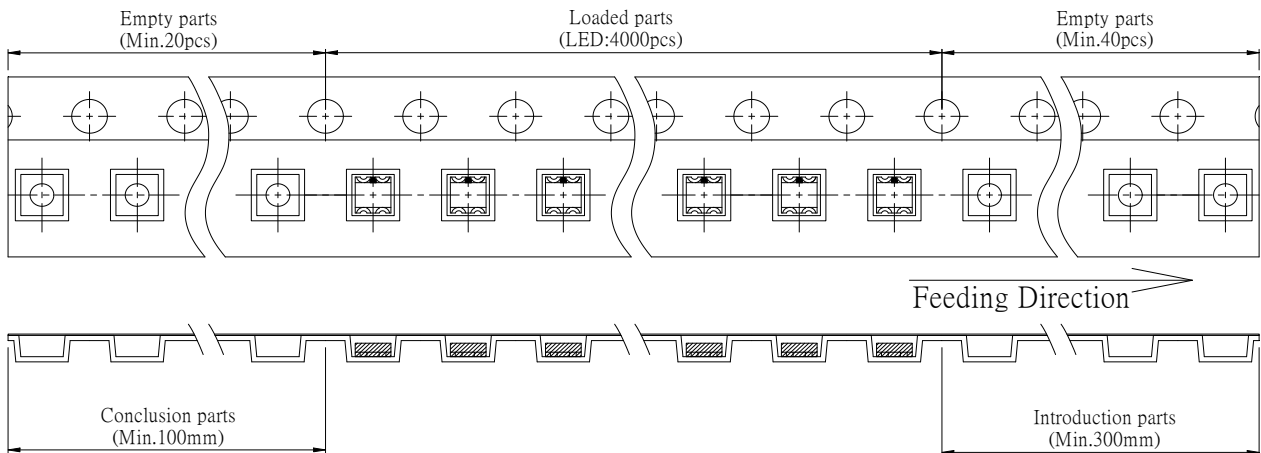

Notes:

1. Empty component pockets are sealed with top cover tape;
2. The maximum number of missing lamps is two;
3. The cathode is oriented towards the tape sprocket hole in accordance with ANSI/EIA RS-481 specifications.
4. 4,000pcs/Reel.

1615 Series SMD Chip LED Lamps Packaging Specifications

- **Packaging specifications**

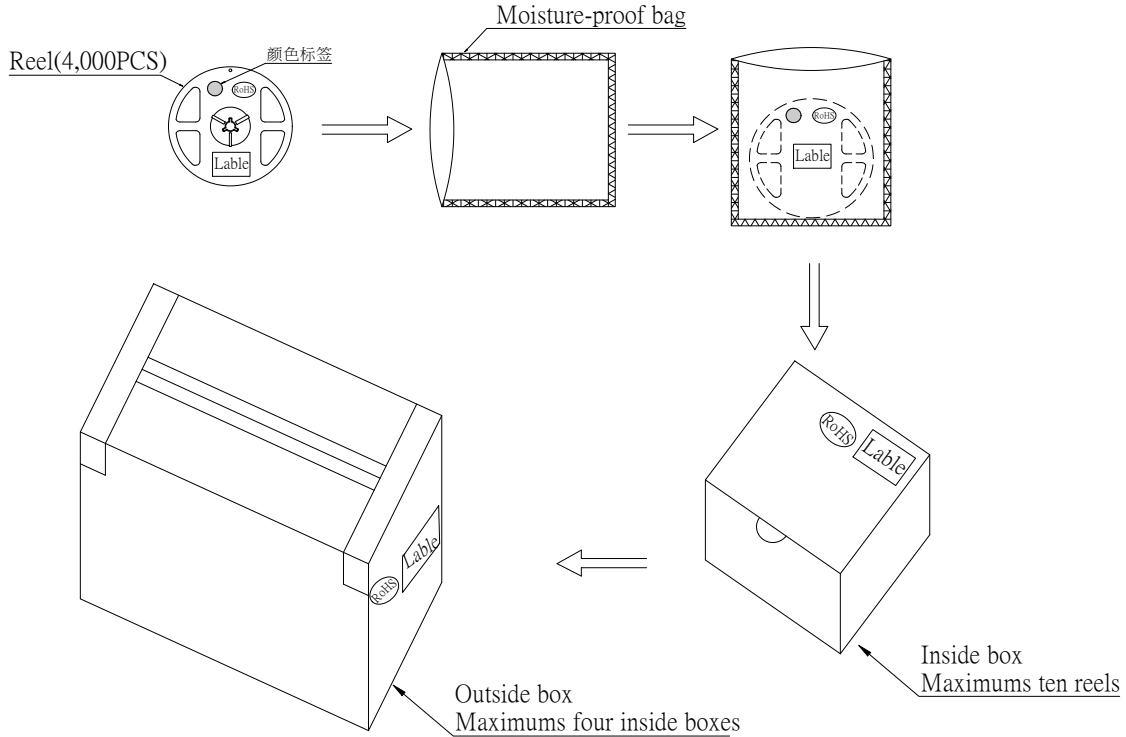

Notes:

Reeled products (numbers of products are 4,000pcs) packed in a seal off moisture-proof bag along with a desiccant one by one, ten moisture-proof bag of maximums (total maximum number of products are 40,000pcs) packed in an inside box (about size: 240x 220x 120mm) and four inside boxes of maximums are put in the outside box (about size: 460mm x 246mm x 250mm) Together with buffer material, and it is packed. (Part No., Lot No., quantity should appear on the label on the moisture-proof bag, part No. And quantity should appear on the label on the cardboard box.) The number of the loading steps of outside box (cardboard box) has it to three steps.