

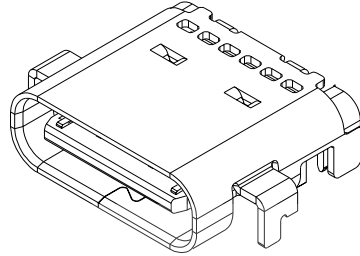

REV.	DESCRIPTION	NAME	DATE
A	NEWS ISSUE		

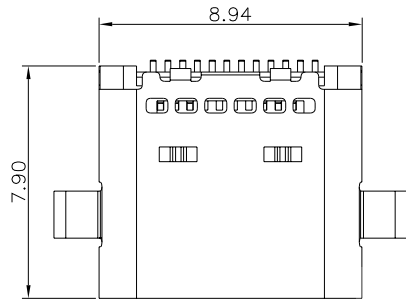

- NOTE:
- MATERIAL:
 - INSULATOR: HIGH TEMPERATURE PLASTIC UL 94 V-0;
 - CONTACT: COPPER ALLOY
 - SHELL: STAINLESS STEEL
 - ELECTRICAL CHARACTERISTICS:
 - CONTACT RESISTANCE: 40mΩ Max FOR INITIAL, 10mΩ CHANGE AFTER TEST, MEASURE AT 20mV, 100mA.
 - CONTACT CURRENT RATING: 5A FOR VBUS PIN; 1.25A FOR VCONN PIN.
 - DIELECTRIC WITHSTANDING VOLTAGE: 100V AC R.M.S.
 - INSULATION RESISTANCE 100MΩ Min
 - OPERATING TEMPERATURE: -25° C ~ 85° C
 - MECHANICAL CHARACTERISTICS:
 - MATING FORCE: 5*20 N.
 - UNMATED FORCE: 8*20N AFTER TEST
 - DURABILITY: 10,000 CYCLES
 - PLATING
 - TERMINAL CONTACT: (SEE TAB) GOLD PLATING ALL OVER 50u" Min NICKEL
 - SHELL: 50u" Min. NICKEL ALL OVER,

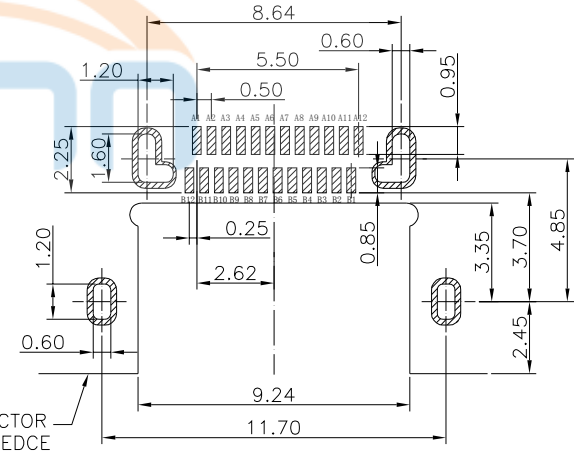
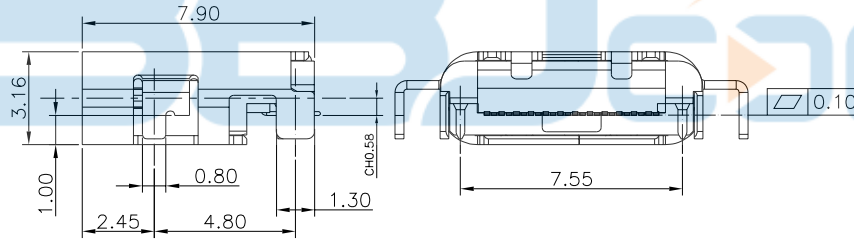
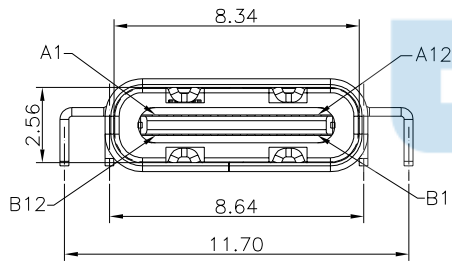

RECOMMENDED P.C.B. LAYOUT
TOLERANCE UNSPECIFIED ±0.05mm

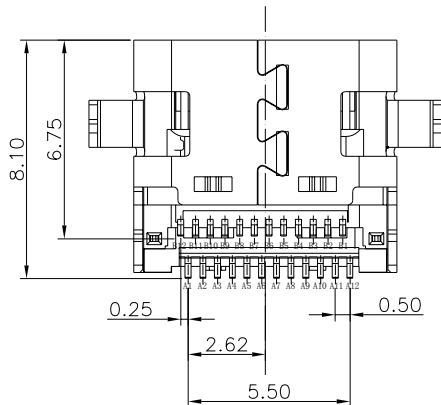

A1	GND	B12	GND
A2	SSTXP1	B11	SSRXP1
A3	SSTXN1	B10	SSRXN1
A4	VBUS	B9	VBUS
A5	CC1	B8	SBU2
A6	DP1	B7	DN2
A7	DN1	B6	DP2
A8	SBU1	B5	CC2
A9	VBUS	B4	VBUS
A10	SSRXN2	B3	SSTXN2
A11	SSRXP2	B2	SSTXP2
A12	GND	B1	GND
PIN	SIGNAL NAME	PIN	SIGNAL NAME

TOLERANCE UNSPECIFIED			
.X	±0.30	.X'	±1.0'
.XX	±0.20	.XX'	±0.5'
.XXX	±0.10	.XXX'	±0.2'

深圳市步步精科技有限公司

TITLE: TYPE-C 24P 母座 L=7.9 双排沉板1.0 CH0.58

DRAWN/DATE	设计	HMY
CHECKED/DATE	审核	LYX
APPROVED/DATE	核准	LJP

SIZE: A4	UNIT: MM.	PART. NO:	UC. 01. 32-1F-0001
SCALE: 1:1	PROJECTION	REV.: 版本	
DWG. PATH	0299-2	SHEET: 页码	



REV.	DESCRIPTION	NAME	DATE
A	NEWS ISSUE		

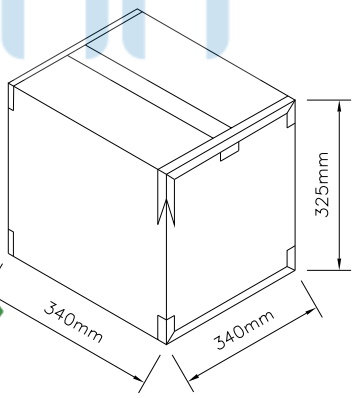
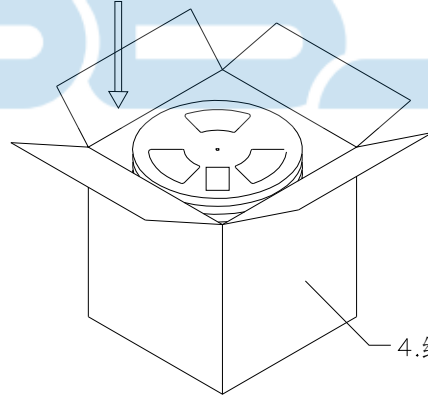
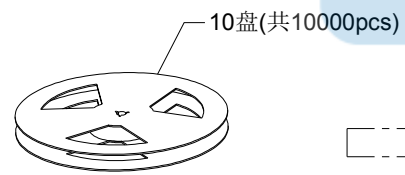
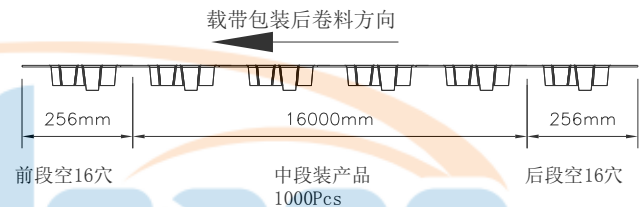
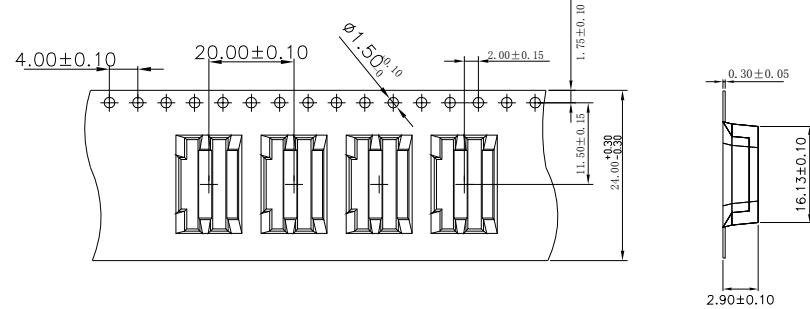
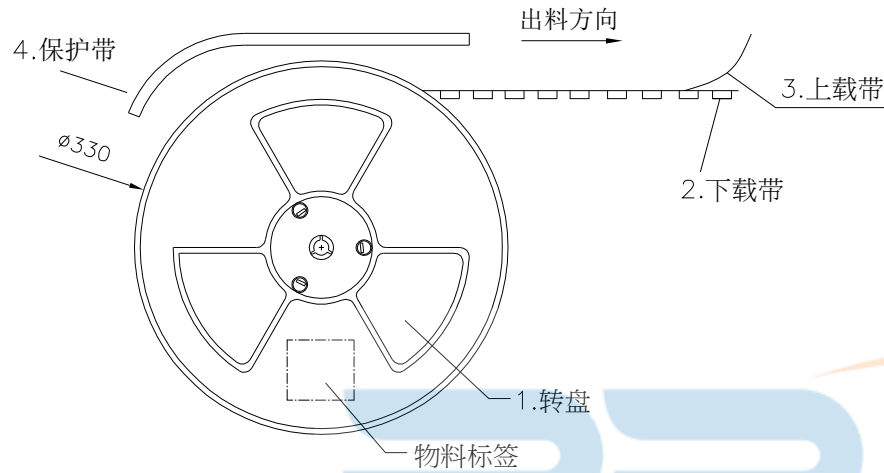

Notes:

1. 每卷前后各空16PCS. 尾部用美纹胶纸封住,
2. 将产品放入载带内, 共放1000PCS, 放满盘后, 再卷一圈保护带, 用美纹胶纸将其封住, 并贴上1Pcs物料标签.
3. 每10卷盘一叠共10000Pcs并装入1个外箱内;
4. 在搬运过程中要轻拿轻放.
5. 在运输中不可堆放过多, 不可有重压现象.
6. 跌落测试条件:

成品箱子从1.2米高自由落体:(三棱六面一角)检验项目:

1. 产品不可跑出下带凹槽.
2. 产品不可有摔伤, 变形.
3. 外箱及内包装材料不可严重破损.



TOLERANCE UNSPECIFIED		深圳市步步精科技有限公司					
.X	±0.30	.X'	±1.0'				
.XX	±0.20	.XX'	±0.5'				
.XXX	±0.10	.XXX'	±0.2'				
DRAWN/ DATE		设计	HMY	SIZE:A4	UNIT:MM.	PART. NO:	UC. 01. 32-1F-0001
CHECKED/ DATE		审核	LYX	SCALE: 1:1	PROJECTION	REV.:	版本
APPROVED/ DATE		核准	LJP	DWG. PATH	0299-2	SHEET: 页码	
		TITLE: TYPE-C 24P 母座 L=7.9 双排沉板1.0 CHO. 58					