

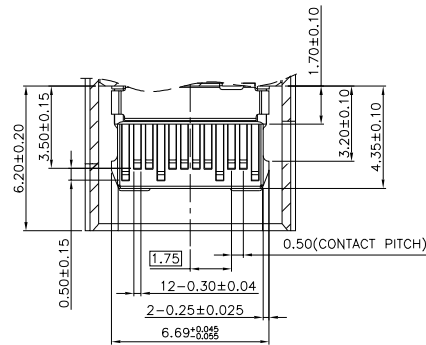

REV.	DESCRIPTION	NAME	DATE
A	NEWS ISSUE		

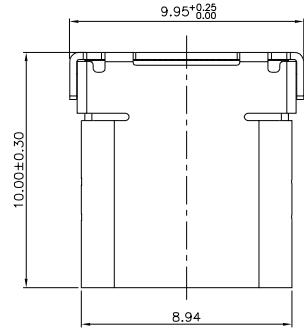

SECTION B-B
SCALE 1:1

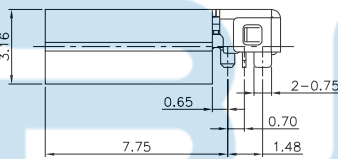
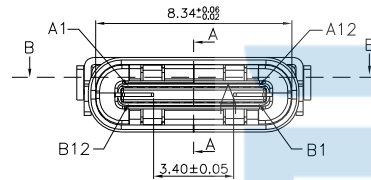
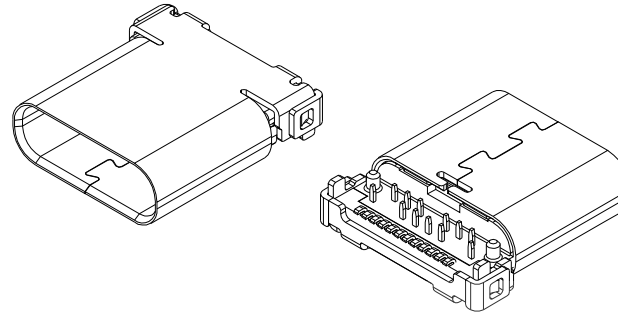

NOTES:

- MATERIAL:
MOLDING: LCP UL94 V-0
CONTACT: COPPER ALLOY,
G/F ON CONTACT AREA, 100u"
Min TIN (LEAD FREE) ON SOLDER AREA,
SHELL: SUS304-H, T=0.30±0.03mm
50u" NICKEL PLATING OVER ALL.
SHILD: SUS304-H, T=0.12±0.03mm
- MECHANICAL:
INSERTION: 5~20N.
EXTRACTION: 8~20N.
DURABILITY: 10000 CYCLES
- ELECTRICAL:
CURRENT: 5A MIN FOR VBUS;
0.25A MIN FOR OTHER.
VOLTAGE: 20 V MAX
WITHSTANDING VOLTAGE: 100V AC.
CONTACT RESISTANCE: 40mΩ MAX.
INSULATION RESISTANCE: 100MΩ MIN.
- ENVIRONMENTAL
TEMPERATURE RANGE -55°C ~ +85°C

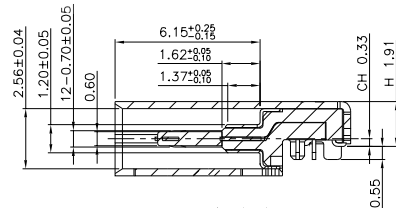
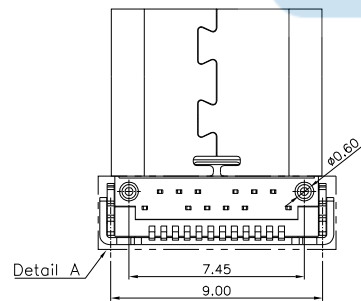

SECTION A-A
SCALE 1:1

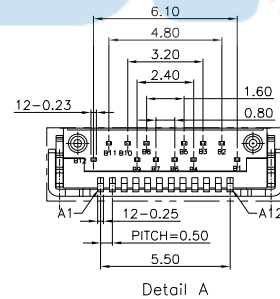

TOLERANCE UNSPECIFIED	
.0	±0.3
.00	±0.2
.000	±0.1
.0°	±1.0°
.00°	±0.5°
.000°	±0.2°

深圳市步步精科技有限公司

TITLE: TYPE-C 24P 母座 沉板1.25 L=10.0外壳无固定脚 CH0.33

DRAWN/ DATE	设计 HMY	SIZE: A4	UNIT: MM.	PART. NO:	UC. 01. 32-1F-0002
CHECKED/ DATE	审核 LYX	SCALE: 1:1	PROJECTION		REV.: 版本
APPROVED/ DATE	核准 LJP	DWG. PATH	0299-2	SHEET: 页码	



REV.	DESCRIPTION	NAME	DATE
A	NEWS ISSUE		

USB TYPE-C FULL-FEATURED RECEPTACLE INTERFACE PIN ASSIGNMENTS

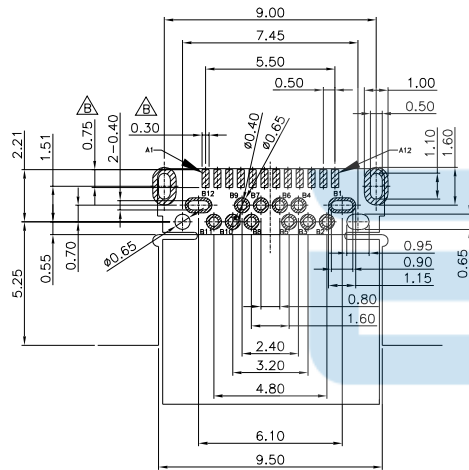

RECOMMEND P.C.B LAYOUT (COMPONENT SIDE)
 TOLERANCE FOR PCB LAYOUT IS ± 0.05
 KEEP OUT AREA

PIN	Signal Name	Description	PIN	Signal Name	Description
A1	GND	Ground return	B12	GND	Ground return
A2	SSTXp1	Positive half of first SuperSpeed TX differential pair	B11	SSTXp1	Positive half of first SuperSpeed TX differential pair
A3	SSTXn1	Negative half of first SuperSpeed TX differential pair	B10	SSTXn1	Negative half of first SuperSpeed TX differential pair
A4	Vbus	Bus Power	B9	Vbus	Bus Power
A5	CC1	Configuration Channel	B8	CC1	Configuration Channel
A6	Dp1	Positive half of the USB 2.0 differential pair-Position 1	B7	Dp1	Positive half of the USB 2.0 differential pair-Position 1
A7	Dn1	Negative half of the USB 2.0 differential pair-Position 1	B6	Dn1	Negative half of the USB 2.0 differential pair-Position 1
A8	RFU1	Reserved for Future Use (RFU)	B5	RFU1	Reserved for Future Use (RFU)
A9	Vbus	Bus Power	B4	Vbus	Bus Power
A10	SSRXn2	Negative half of second SuperSpeed RX differential pair	B3	SSRXn2	Negative half of second SuperSpeed RX differential pair
A11	SSRXp2	Positive half of second SuperSpeed RX differential pair	B2	SSRXp2	Positive half of second SuperSpeed RX differential pair
A12	GND	Ground return	B1	GND	Ground return



TOLERANCE UNSPECIFIED .0 ± 0.3 .00 ± 0.2 .000 ± 0.1 .0° $\pm 1.0^\circ$.00° $\pm 0.5^\circ$.000° $\pm 0.2^\circ$		<h2>深圳市步步精科技有限公司</h2>			
		TITLE: TYPE-C 24P 母座 沉板1.25 L=10.0外壳无固定脚 CH0.33			
DRAWN/DATE	设计 HMY	SIZE:A4	UNIT:MM.	PART. NO:	UC. 01. 32-1F-0002
CHECKED/DATE	审核 LYX	SCALE: 1:1		PROJECTION	REV.: 版本
APPROVED/DATE	核准 LJP	DWG. PATH	0299-2		SHEET: 页码

REV.	DESCRIPTION	NAME	DATE
A	NEWS ISSUE		

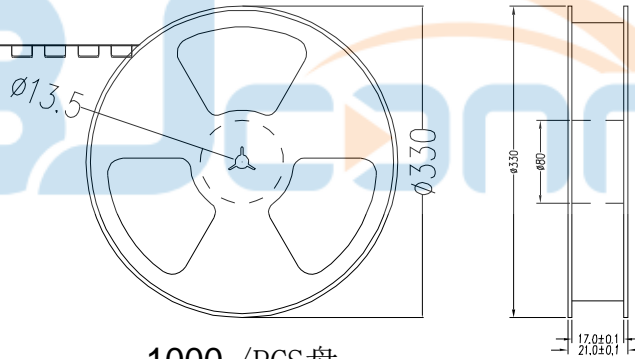
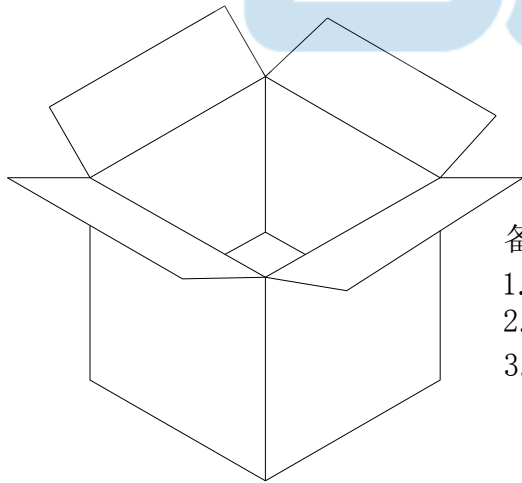
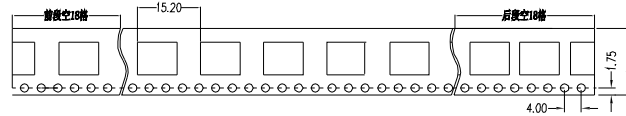
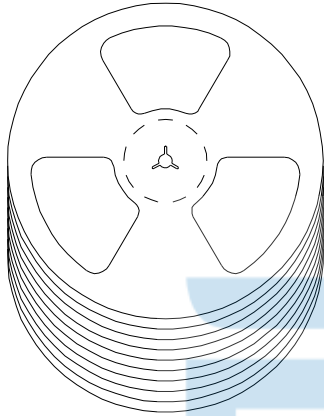

1000 /PCS盘

备注:

1. 包装数量: 1000/PCS/盘, 10盘/箱或15盘/箱。
2. 包装袋长度: 每盘前后各空10-20个空格, 中间包装。

3. 材质:

载体: 聚丙烯 (PS), 阻抗 $10^{6-9} \Omega$

上带: 聚乙烯 (PET), 阻抗 $10^{6-11} \Omega$

卷盘: 聚苯乙烯。

纸箱规格: 345*345*23MM

纸箱规格: 345*345*35MM



深圳市步步精科技有限公司

TITLE: TYPE-C 24P 母座 沉板1.25 L=10.0外壳无固定脚 CH0.33

TOLERANCE UNSPECIFIED					
.0	±0.35				
.00	±0.25				
.000	±0.15				
X.°	±2.00°				
CUSTOMER DRAWING					
DRAWN/ DATE	设计 HMY	SIZE:A4	UNIT:MM.	PART. NO:	UC. 01. 32-1F-0002
CHECKED/ DATE	审核 LYX	SCALE: 1:1	PROJECTION	REV.: 版本	
APPROVED/ DATE	核准 LJP	DWG. PATH	0299-2	SHEET: 页码	