

- Note:
- Material:
    - Housing: PA9T
    - Contact: C5191, t=0.20mm
    - Shell: Kirsite
  - ELECTRICAL:
    - CURRENT RATING:
      - VBUS AND GND CONTACTS RATED AT 1.25- A PARALLELED FOR A TOTAL OF 5A;
      - INITIAL CONTACT RESISTANCE :40 MEGOHM S
      - DIELECTRIC WITHSTANDING VOLTAGE: 100V AC MIN;
    - MECHANICAL CHARACTERISTICS:
      - MATING FORCE:5~20N
      - UNMATING FORCE:8~20N(INITIAL), 6~20N(AFTER 10000 CYCLES)
      - FREQUENCY: 200±50 CYCLES /HOUR,10000 CYCLES
      - OPERATING TEMPERATURE ;-40°~80°.

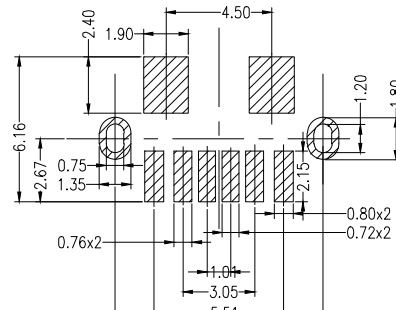
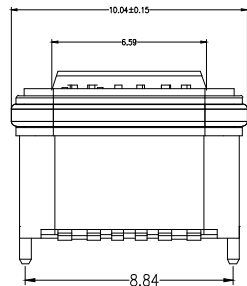
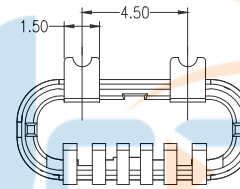
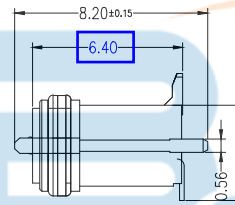
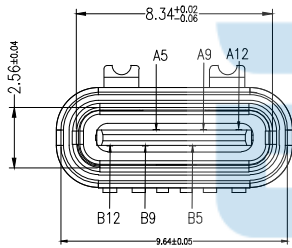
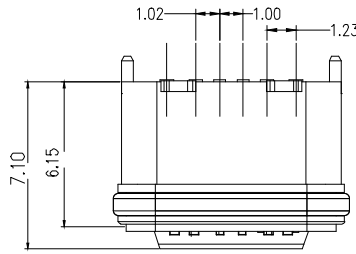

PCB LAYOUT 图仅供参考

TABLE B

A5	CC1	B12	GND
A9	VBUS	B9	VBUS
A12	GND	B1	GND
PIN	SIGNAL NAME	PIN	SIGNAL NAME

MODEL NO: XX		FINISH: SEE NOTE	
UNIT: MM	SIZE: A4	COLOR: SEE NOTE	
TOLERANCE UNSPECIFIED		DR: HMY	CHK: LYX
.x	±0.15	APP: LJP	
.xx	±0.10		
.xxx	±0.05		
Ang.	±1°		

MATERIAL: SEE NOTE			深圳市步步精科技有限公司		
TYPE-C 6P 防水母座立贴H=6.40/锌合金外壳 IPX7			TITLE:		
PART.NO: UC.01.63-1J-0001			REV: A		
SCALE: 5:1	0395-1				

REV.	ECN NO	LOCATIONS	DESCRIPTION	DATE

REV.	ECN NO	LOCATIONS	DESCRIPTION	DATE

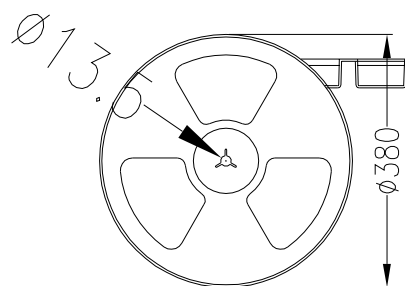

0.8K/盘

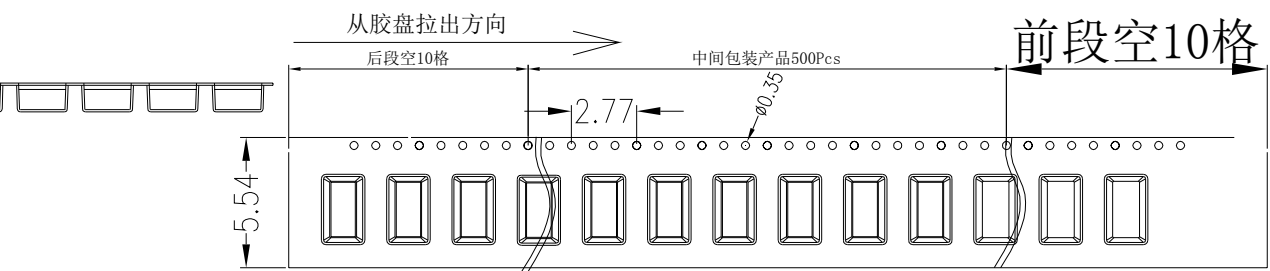

前段空10格

中间包装产品500Pcs

从胶盘拉出方向

后段空10格

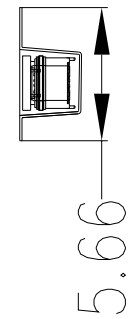

5.66

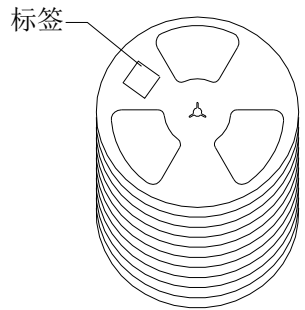

7盘

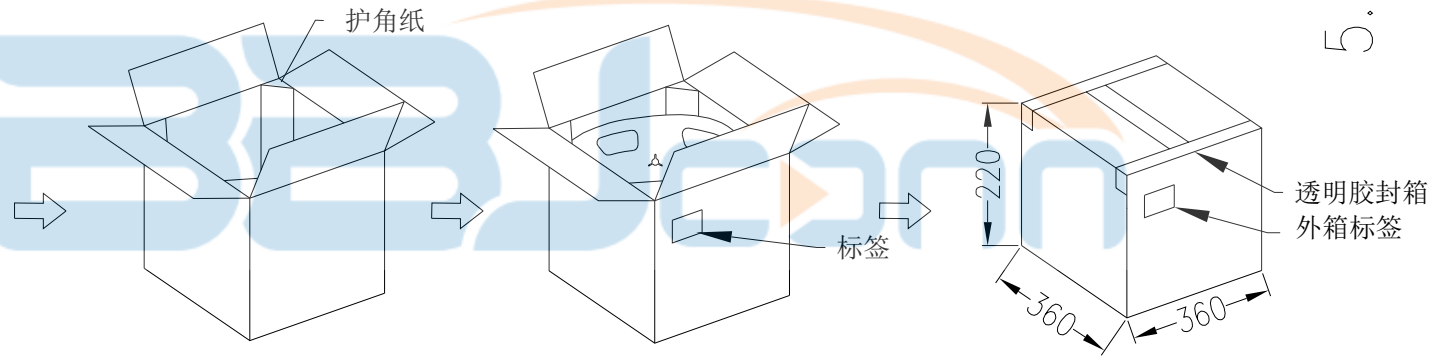

透明胶封箱  
外箱标签

5.6K/箱 纸箱规格:420\*420\*220mm

- 备注:
1. 每盘前面空10个空格后面空10个空格, 中间包装500PCS.
  2. 每箱包装7盘, 共包装3,500PCS.



MODEL NO: XX		MATERIAL: SEE NOTE		深圳市步步精科技有限公司	
UNIT: MM		FINISH: SEE NOTE			
SIZE: A4		COLOR: SEE NOTE		TITLE:	
TOLERANCE UNSPECIFIED		DR: HMY		TYPE-C 6P 防水母座立贴H=6.40/锌合金外壳 1PX7	
.x	±0.15	CHK: LYX		PART NO: UC.01.63-1J-0001	
.xx	±0.10	APP: LJP		REV: A	
.xxx	±0.05			SCALE: 0395-1	
Ang.	±1°				