



NOTE:

1. MATERIAL SPECIFICATION:
 1. HOUSING: HIGH TEMPERATURE RESISTANT PLASTIC, UL94 V-0.
 2. CONTACTS: COPPER ALLOY
2. PLATING SPECIFICATION:
 - 2-1. CONTACTS:
 - Ni 50u" MIN. UNDER PLATED OVER ALL.
 - Au PLATED ON THE FUNCTIONAL AREA OF CONTACT.
 - (GOLD PLATING THICKNESS FOLLOW THE P/N)
 - GOLD FLASH PLATING ON SOLDER AREA
 - 2-2. FRONT SHELL:
 - Ni 30u" MIN. UNDER PLATED OVER ALL.
3. MECHANICAL PERFORMANCE,
 - 3-1. INSERTION FORCE: 0.5~2.0kgf.
 - 3-2. REMOVAL FORCE: 0.8kgf~2.0kgf.
 - 3-3. DURABILITY: 3000 CYCLES.
4. ELECTRICAL PERFORMANCE,
 - 4-1. CURRENT RATING: 5.0A
VOLTAGE RATING: 20V
 - 4-2. INSULATION RESISTANCE: 100MΩ MIN
 - 4-3. DIELECTRIC WITHSTAND VOLTAGE, AC 100V FOR 1 MINUTE.
 - 4-4. LOW CONTACT RESISTANCE: INITIAL 40MΩ /AFTER 50MΩ
5. ENVIRONMENTAL PERFORMANCE:
 - OPERATING TEMPERATURE: -30°C~+80°C.
6. IR REFLOW:
 - THE PEAK TEMPERATURE ON THE BOARD SHALL BE MAINTAINED FOR 10 SECONDS AT 260°C.

Code	DIM L	DIM A
0	6.80	4.90
1	6.50	4.60



USB TYPE-C PIN ASSIGNMENTS

PIN NUMBER	SIGNAL NAME
A5	CC1
A9	VBUS
A12	GND
B12	GND
B9	VBUS
B5	CC2

深圳市步步精科技有限公司

TITLE: TYPE-C 6P母座 L=6.8 沉板1.6 CHO.02

TOLERANCE UNSPECIFIED					
.0	±0.35	SIZE:A4	UNIT:MM.	PART. NO: UC.01.33-11-0001	
.00	±0.25	CHECKED/ DATE	SCALE: 1:1	PROJECTION	REV.: 版本
.000	±0.15	APPROVED/ DATE	DWG. PATH	0100-2	SHEET: 页码
X."	±2.00"				
CUSTOMER DRAWING					

RECOMMEND P.C.B LAYOUT (COMPONENT SIDE)
TOLERANCE FOR PCB LAYOUT IS ± 0.05

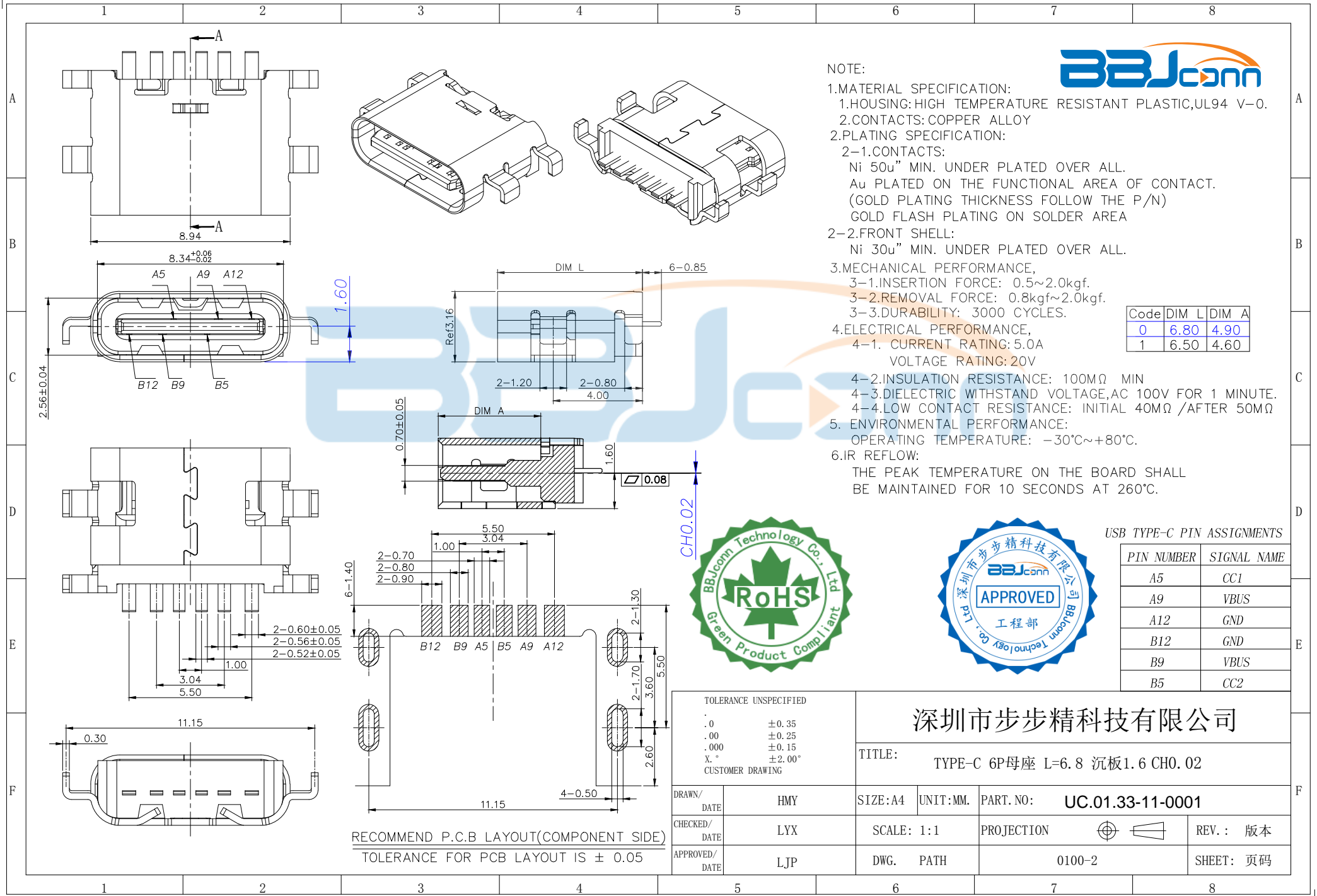

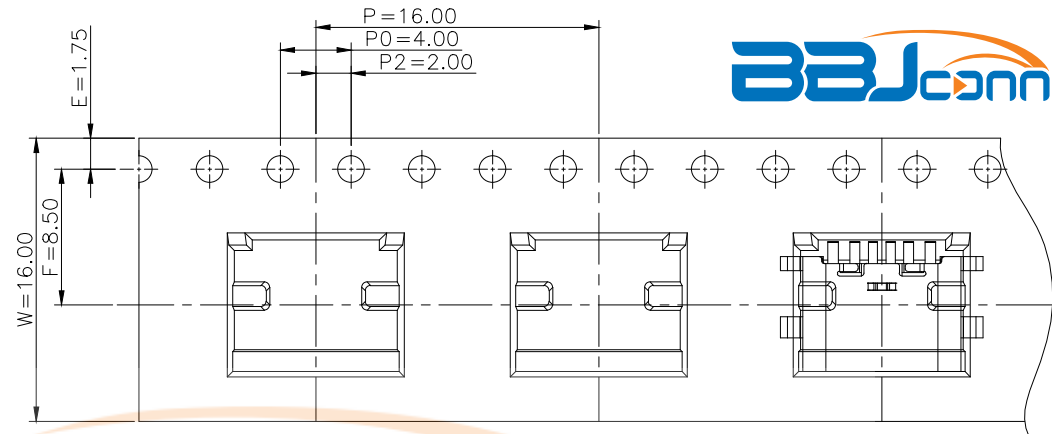
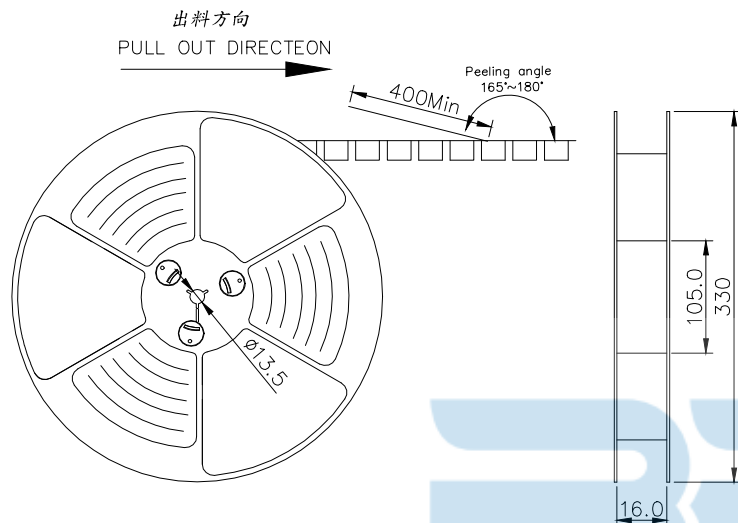

NOTES

1. 帶子引導長度
LEAD TAPE LENGTH

出料方向
PULL OUT DIRECTEON

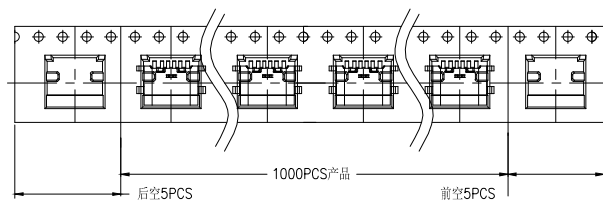

2. 上帶剝力為: 0.1~1.3N(10.2gf~130gf)
PEELING OFF FORCE OF TOP TAPE: 0.1~1.3N(10.2gf~130gf)

出貨運輸過程中一定注意:
THIS REQUIREMENT SHOULD BE APPLIED AT SHIPMENT:
卷帶在運輸過程中不能散開
PEELING OFF SHOULD NOT BE ALLOWED DURING TRANSPORTATION

TAPE & REEL 14 PCS

1 REEL
= 1000 PCS

BOX

DIMENSIONS:
33.5X33.5X30.5

1 CARTON
=14 REELS
=14000 PCS

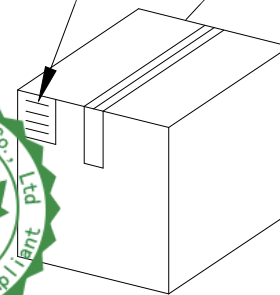
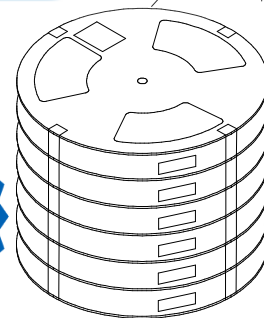

包裝明細表 (The detail of the packing) Carton						
產品料號 (Product No.)	包裝容量 (Packing Capacity)			重量 Weight (Kg)		
	pcs/box	boxs/Carton	Pcs/Box	N.W./Pcs	N.W./Box	G.W./Box
	1000	14	14000	----	----	----

TOLERANCE UNSPECIFIED		<p>深圳市步步精科技有限公司</p> <p>TITLE: TYPE-C 6P母座 L=6.8 沉板1.6 CH0.02</p>					
DRAWN/ DATE	HMY	SIZE:A4	UNIT:MM.	PART. NO:	UC.01.33-11-0001		
CHECKED/ DATE	LYX	SCALE: 1:1	PROJECTION			REV.:	版本
APPROVED/ DATE	LJP	DWG. PATH	0100-2	SHEET:			页码