

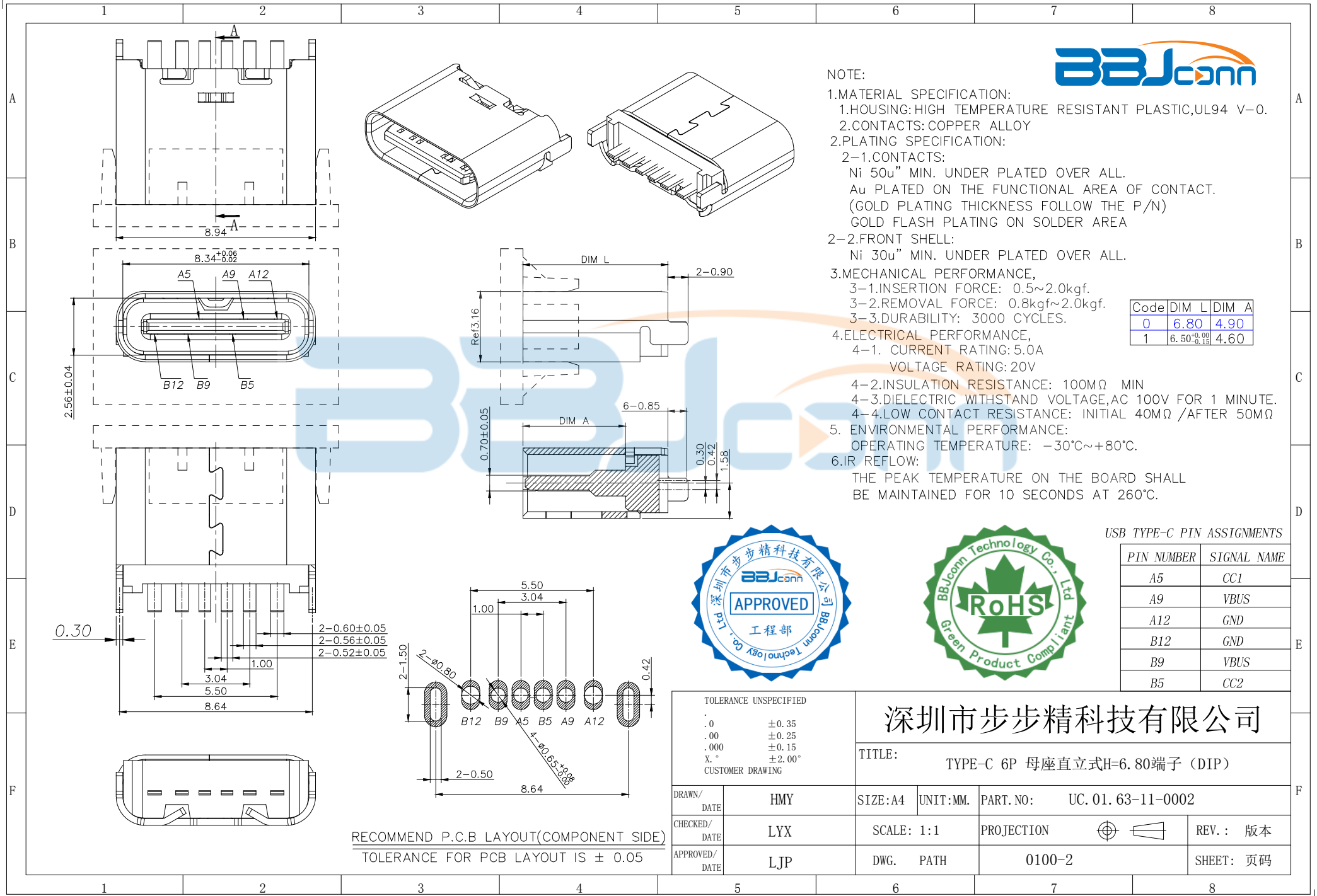

NOTE:

1. MATERIAL SPECIFICATION:
  1. HOUSING: HIGH TEMPERATURE RESISTANT PLASTIC, UL94 V-0.
  2. CONTACTS: COPPER ALLOY
2. PLATING SPECIFICATION:
  - 2-1. CONTACTS:
    - Ni 50u" MIN. UNDER PLATED OVER ALL.
    - Au PLATED ON THE FUNCTIONAL AREA OF CONTACT.
    - (GOLD PLATING THICKNESS FOLLOW THE P/N)
    - GOLD FLASH PLATING ON SOLDER AREA
  - 2-2. FRONT SHELL:
    - Ni 30u" MIN. UNDER PLATED OVER ALL.
3. MECHANICAL PERFORMANCE,
  - 3-1. INSERTION FORCE: 0.5~2.0kgf.
  - 3-2. REMOVAL FORCE: 0.8kgf~2.0kgf.
  - 3-3. DURABILITY: 3000 CYCLES.
4. ELECTRICAL PERFORMANCE,
  - 4-1. CURRENT RATING: 5.0A  
VOLTAGE RATING: 20V
  - 4-2. INSULATION RESISTANCE: 100MΩ MIN
  - 4-3. DIELECTRIC WITHSTAND VOLTAGE, AC 100V FOR 1 MINUTE.
  - 4-4. LOW CONTACT RESISTANCE: INITIAL 40MΩ /AFTER 50MΩ
5. ENVIRONMENTAL PERFORMANCE:
  - OPERATING TEMPERATURE: -30°C~+80°C.
6. IR REFLOW:
  - THE PEAK TEMPERATURE ON THE BOARD SHALL BE MAINTAINED FOR 10 SECONDS AT 260°C.

Code	DIM L	DIM A
0	6.80	4.90
1	6.50 <sup>+0.00</sup> <sub>-0.15</sub>	4.60



USB TYPE-C PIN ASSIGNMENTS

PIN NUMBER	SIGNAL NAME
A5	CC1
A9	VBUS
A12	GND
B12	GND
B9	VBUS
B5	CC2

TOLERANCE UNSPECIFIED		<p>深圳市步步精科技有限公司</p> <p>TITLE: TYPE-C 6P 母座直立式H=6.80端子 (DIP)</p>	
.0	±0.35	SIZE:A4	UNIT:MM.
.00	±0.25	PART. NO:	UC. 01.63-11-0002
.000	±0.15	CHECKED/ DATE	LYX
X. "	±2.00"	SCALE: 1:1	PROJECTION
CUSTOMER DRAWING		DWG. PATH	0100-2
DRAWN/ DATE	HMY	REV.:	版本
CHECKED/ DATE	LYX	SHEET:	页码
APPROVED/ DATE	LJP		

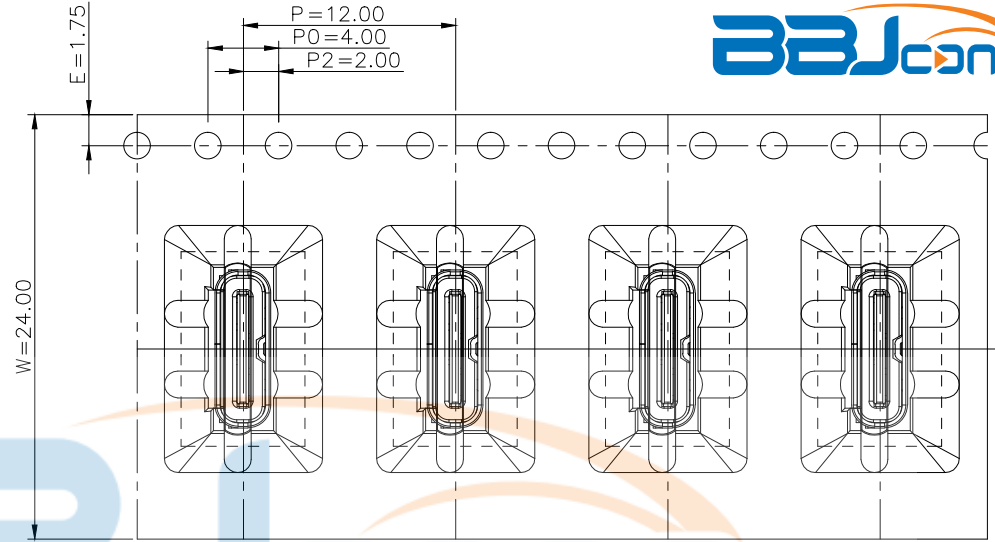
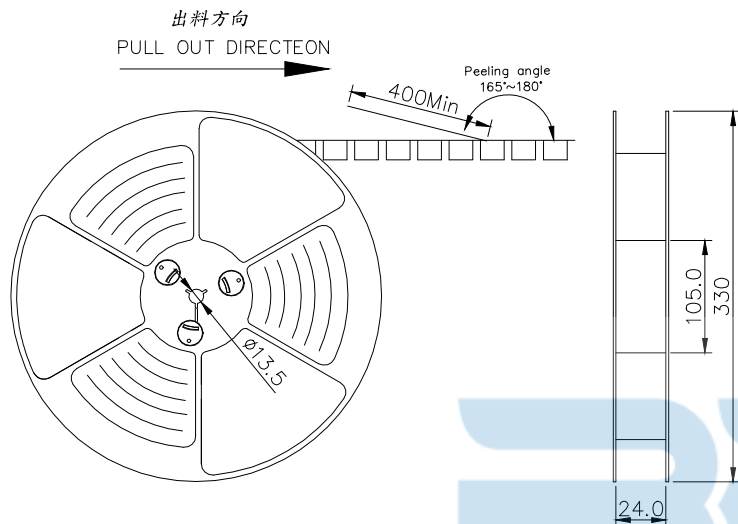

NOTES

1. 帶子引導長度  
LEAD TAPE LENGTH  
出料方向  
PULL OUT DIRECTEON

出料方向  
PULL OUT DIRECTEON

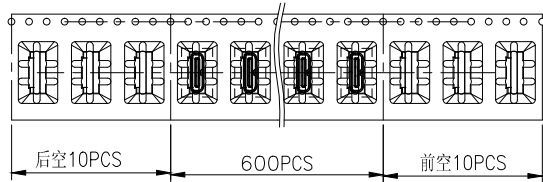

2. 上帶 剝力力為 : 0.1~1.3N(10.2gf~130gf)  
PEELING OFF FORCE OF TOP TAPE:0.1~1.3N(10.2gf~130gf)  
出貨運輸過程中一定注意:  
THIS REQUIREMENT SHOULD BE APPLIED AT SHIPMENT:  
卷帶在運輸過程中不能散開  
PEELING OFF SHOULD NOT BE ALLOWED DURING TRANSPORTATION

TAPE & REEL 10 PCS

1 REEL  
= 600 PCS

BOX

DIMENSIONS:  
33.5X33.5X30.5

1 CARTON  
=10 REELS  
=6000 PCS

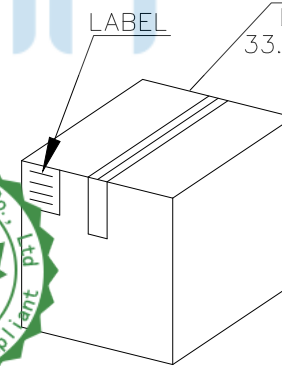
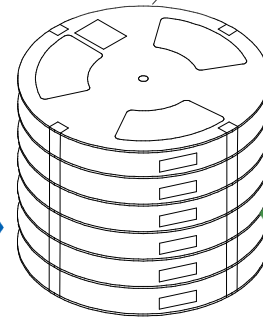

TOLERANCE UNSPECIFIED	
.0	±0.35
.00	±0.25
.000	±0.15
X. °	±2.00°
CUSTOMER DRAWING	

深圳市步步精科技有限公司

TITLE: TYPE-C 6P 母座直立式H=6.80端子 (DIP)

DRAWN/ DATE	HMY	SIZE:A4	UNIT:MM.	PART. NO:	UC. 01. 63-11-0002
CHECKED/ DATE	LYX	SCALE: 1:1	PROJECTION	REV.:	版本
APPROVED/ DATE	LJP	DWG. PATH	0100-2	SHEET:	页码

包裝明細表 (The detail of the packing) Carton						
產品料號 (Product No.)	包裝容量 (Packing Capacity)			重量 Weight (Kg)		
	pcs/box	boxes/Carton	Pcs/Box	N.W./Pcs	N.W./Box	G.W./Box
	600	10	6000	----	----	----