



REV.	DESCRIPTION	NAME	DATE
1		JACKSON	2021.01.15

NOTES:

1. ELECTRICAL:

1.1. CONTACT CURRENT RATING 5.0A FOR VBUS AND GND (PINS A4 A9 B4 B9)

1.2. INSULATION RESISTANCE: 100 MEGAOHMS MIN. AT 250VDC.

1.3. DIELECTRIC WITHSTANDING VOLTAGE: 100VAC MIN.

1.4. LOW CONTACT RESISTANCE:

INITIAL 40m Ω MAX. AFTER 50m Ω MAX.

2. MECHANICAL CHARACTERISTICS:

2.1. INSERTION FORCE: 5N±20N.

2.2. EXTRACTION FORCE:

8N±20N FORM 1 TO 1000CYCLES.

6N±20N FORM 1001 TO 10000CYCLES.

2.3. DURABILITY: 10,000 MATING CYCLES

2.4. OPERATING TEMPERATURE: -55° C TO +85° C

3. COPLANARITY: 0.10MAX.

4. ROHS REACHER.

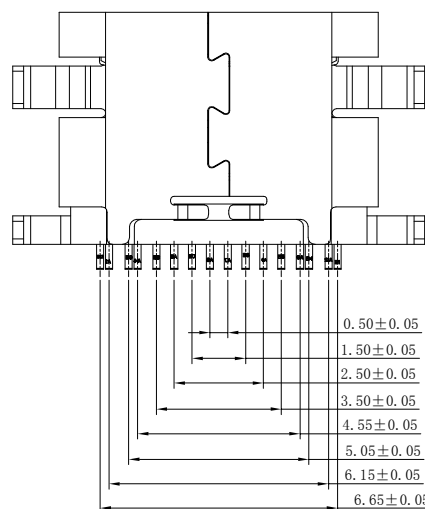
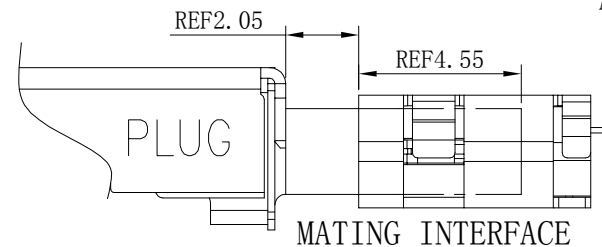
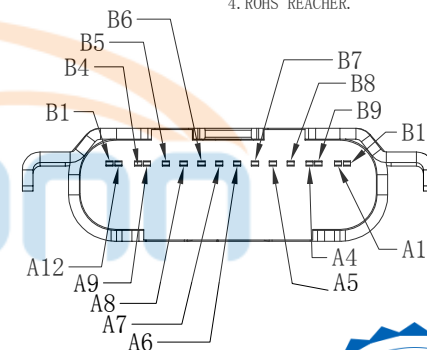
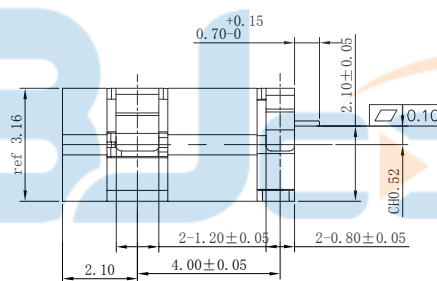
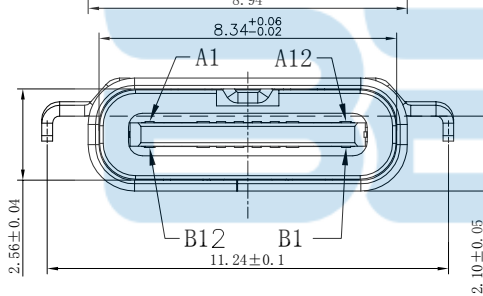
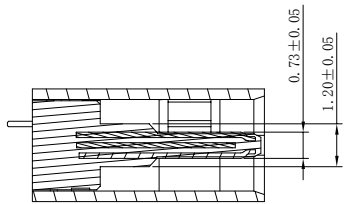
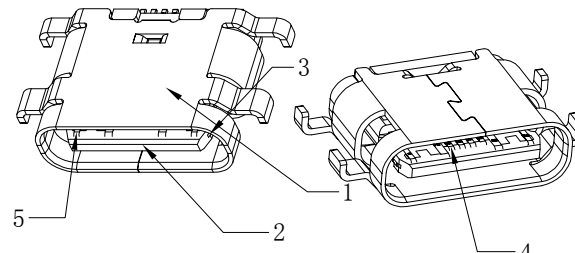
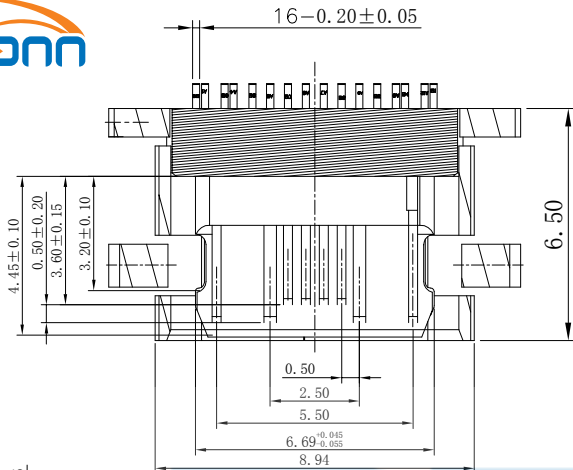

TOLERANCE UNSPECIFIED	
.0	±0.35
.00	±0.25
.000	±0.15
X.°	±2.00°
CUSTOMER DRAWING	
DRAWN/DATE	LXF
CHECKED/DATE	LYX
APPROVED/DATE	LJP

深圳市步步精科技有限公司

TITLE: TYPE-C 16P 母座L=6.5沉板2.1 (CH=0.52mm)

SIZE:A4	UNIT:MM.	PART.NO:	UC.01.31-1N-0001
CHECKED/DATE	LYX	SCALE: 1:1	PROJECTION
APPROVED/DATE	LJP	DWG. PATH	9999-9
			REV.: 版本
			SHEET: 页码



REV.	DESCRIPTION	NAME	DATE
1		JACKSON	2021. 01. 14

PIN	SIGNAL NAME	PIN	SIGNAL NAME
A1	GND	B12	GND
A2	/	B11	/
A3		B10	
A4	VBUS	B9	VBUS
A5	CC1	B8	SBU2
A6	Dp1	B7	Dn2
A7	Dn1	B6	Dp2
A8	SBU1	B5	CC2
A9	VBUS	B4	VBUS
A10	/	B3	/
A11		B2	
A12	GND	B1	GND

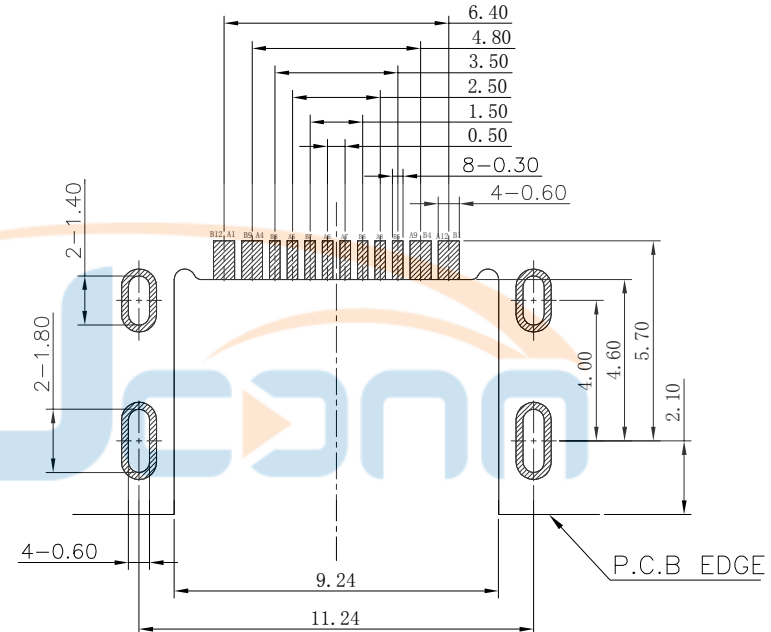
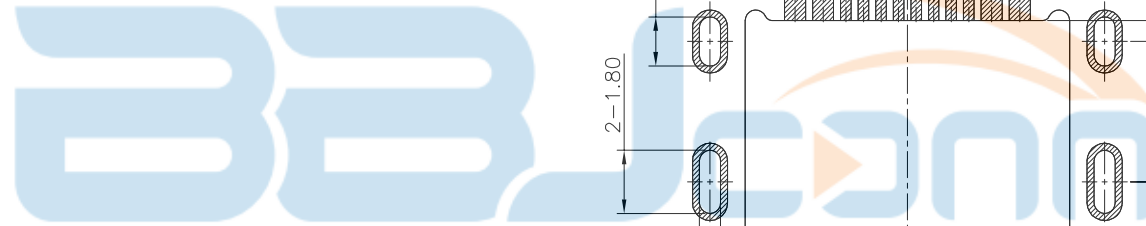

RECOMMEND P. C. B LAYOUT (COMPONENT SIDE)
TOLERANCE FOR PCB LAYOUT IS ± 0.05



TABLE

ITEM	PART NAME	QTY	MATERIAL	REMARK
1	SHELL	1PCS	STAINLESS	NICKEL PLATED 50u'' MIN. OVER ALL
2	INSERT HOUSING	1PCS	LCP	UL94V-0
3	Mid-PLATE	1PCS	STAINLESS	NI PLATED 50u'' MIN. OVER ALL
4	TOP CONTACT	1SET	COPPER ALLOY	NICKEL PLATED 50u'' MIN OVER ALL. Au 1u'' ON CONTACT AREA.
5	BOTTOM CONTACT	1SET	COPPER ALLOY	GOLD FLASH PLATING ON SOLDER AREA

TOLERANCE UNSPECIFIED	
.0	± 0.35
.00	± 0.25
.000	± 0.15
X. °	$\pm 2.00^\circ$
CUSTOMER DRAWING	

深圳市步步精科技有限公司

TITLE: TYPE-C 16P 母座L=6.5沉板2.1(CH=0.52mm)

DRAWN/ DATE	LXF	SIZE:A4	UNIT:MM.	PART. NO:	UC.01.31-1N-0001
CHECKED/ DATE	LYX	SCALE: 1:1	PROJECTION		REV.: 版本
APPROVED/ DATE	LJP	DWG. PATH	9999-9		SHEET: 页码

REV.	DESCRIPTION	NAME	DATE
1		JACKSON	2021. 01. 15

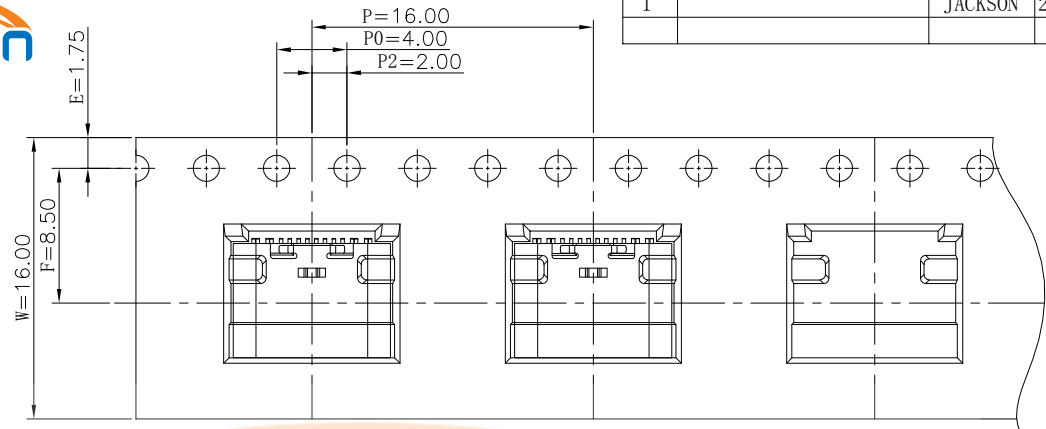
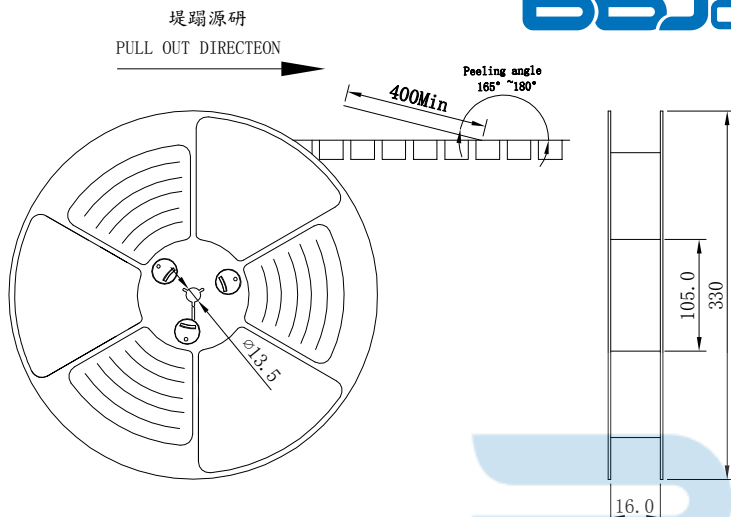

NOTES

- 帶子引導長度
LEAD TAPE LENGTH
出料方向
PULL OUT DIRECTEON

堤蹋源研
PULL OUT DIRECTEON

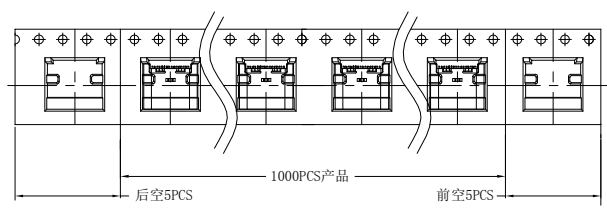

- 上帶 剝力力為: 0.1~1.3N(10. 2gf~130gf)
PEELING OFF FORCE OF TOP TAPE:0.1~1. 3N(10. 2gf~130gf)
出貨'運輸過程中一定注意:
THIS REQUIREMENT SHOULD BE APPLIED AT SHIPMENT:
卷帶在運輸過程中不能散開
PEELING OFF SHOULD NOT BE ALLOWED DURING TRANSPORTATION

TAPE & REEL 10 PCS

1 REEL = 1000 PCS

BOX

DIMENSIONS: 33. 5X33. 5X30. 5

1 CARTON = 10 REELS = 10000 PCS



TOLERANCE UNSPECIFIED	
.0	±0.35
.00	±0.25
.000	±0.15
X. °	±2.00°

CUSTOMER DRAWING

深圳市步步精科技有限公司

TITLE: TYPE-C 16P 母座L=6.5沉板2.1(CH=0.52mm)

DRAWN/ DATE	LXF	SIZE:A4	UNIT:MM.	PART. NO:	UC.01.31-1N-0001
CHECKED/ DATE	LYX	SCALE: 1:1	PROJECTION	REV. :	1
APPROVED/ DATE	LJP	DWG. PATH	9999-9	SHEET:	3/3

包裝明細表 (The detail of the packing) Carton

產品料號 (Product No.)	包裝容量(Packing Capacity)			重量 Weight (Kg)		
	pcs/box	boxes/Carton	Pcs/Box	N. W. /Pcs	N. W. /Box	G. W. /Box
	1000	10	10000	----	----	----