

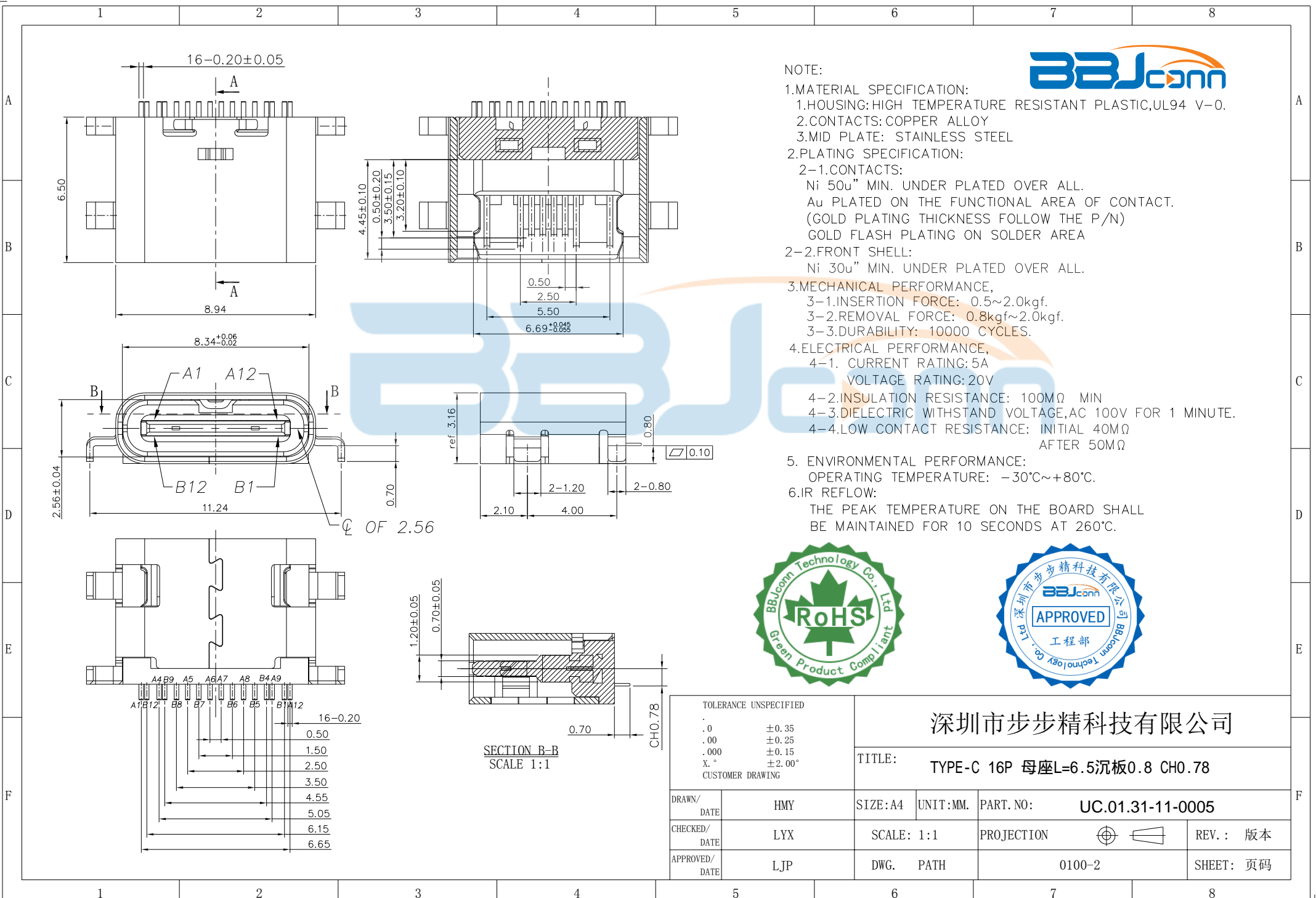

NOTE:

- 1.MATERIAL SPECIFICATION:
 - 1.HOUSING:HIGH TEMPERATURE RESISTANT PLASTIC,UL94 V-0.
 - 2.CONTACTS:COPPER ALLOY
 - 3.MID PLATE: STAINLESS STEEL
- 2.PLATING SPECIFICATION:
 - 2-1.CONTACTS:
 - Ni 50u" MIN. UNDER PLATED OVER ALL.
 - Au PLATED ON THE FUNCTIONAL AREA OF CONTACT.
 - (GOLD PLATING THICKNESS FOLLOW THE P/N)
 - GOLD FLASH PLATING ON SOLDER AREA
 - 2-2.FRONT SHELL:
 - Ni 30u" MIN. UNDER PLATED OVER ALL.
- 3.MECHANICAL PERFORMANCE,
 - 3-1.INSERTION FORCE: 0.5~2.0kgf.
 - 3-2.REMOVAL FORCE: 0.8kgf~2.0kgf.
 - 3-3.DURABILITY: 10000 CYCLES.
- 4.ELECTRICAL PERFORMANCE,
 - 4-1. CURRENT RATING: 5A
VOLTAGE RATING: 20V
 - 4-2.INSULATION RESISTANCE: 100MΩ MIN
 - 4-3.DIELECTRIC WITHSTAND VOLTAGE,AC 100V FOR 1 MINUTE.
 - 4-4.LOW CONTACT RESISTANCE: INITIAL 40MΩ
AFTER 50MΩ
5. ENVIRONMENTAL PERFORMANCE:
 - OPERATING TEMPERATURE: -30°C~+80°C.
- 6.IR REFLOW:
 - THE PEAK TEMPERATURE ON THE BOARD SHALL BE MAINTAINED FOR 10 SECONDS AT 260°C.



深圳市步步精科技有限公司

TITLE: TYPE-C 16P 母座L=6.5沉板0.8 CH0.78

TOLERANCE UNSPECIFIED					
.0	±0.35				
.00	±0.25				
.000	±0.15				
X. °	±2.00°				
CUSTOMER DRAWING					
DRAWN/ DATE	HMY	SIZE:A4	UNIT:MM.	PART. NO:	UC.01.31-11-0005
CHECKED/ DATE	LYX	SCALE: 1:1	PROJECTION	REV.:	版本
APPROVED/ DATE	LJP	DWG. PATH		0100-2	SHEET: 页码

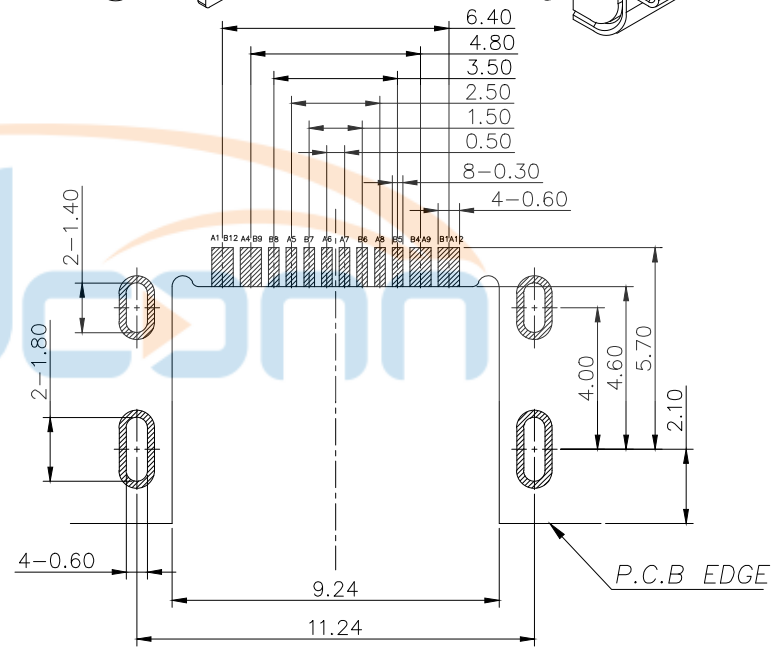
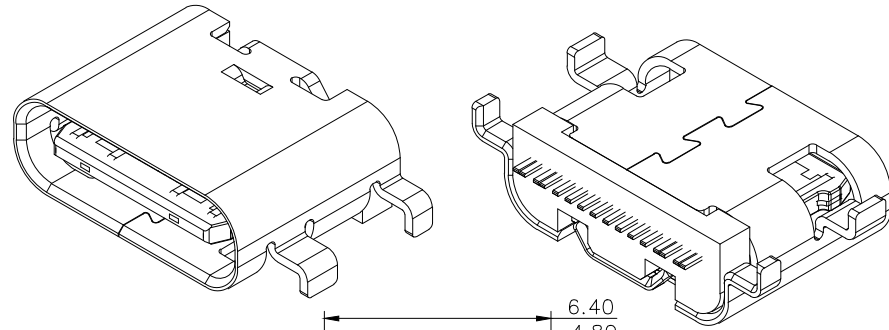

USB TYPE-C PIN ASSIGNMENTS

PIN NUMBER	SIGNAL NAME	PIN NUMBER	SIGNAL NAME
A1	GND	B12	GND
A4	VBUS	B9	VBUS
A5	CC1	B8	SBU2
A6	Dp1	B7	Dn2
A7	Dn1	B6	Dp2
A8	SBU1	B5	CC2
A9	VBUS	B4	VBUS
A12	GND	B1	GND

RECOMMEND P.C.B LAYOUT (COMPONENT SIDE)

TOLERANCE FOR PCB LAYOUT IS ± 0.05



TOLERANCE UNSPECIFIED		深圳市步步精科技有限公司 TITLE: TYPE-C 16P 母座L=6.5沉板0.8 CH0.78			
.0	± 0.35				
.00	± 0.25	DRAWN/ DATE		SIZE: A4	UNIT: MM.
.000	± 0.15	CHECKED/ DATE		PART. NO: UC.01.31-11-0005	
X.°	$\pm 2.00^\circ$	APPROVED/ DATE		SCALE: 1:1	PROJECTION
CUSTOMER DRAWING		LJP		DWG. PATH	0100-2
				REV.: 版本	
				SHEET: 页码	

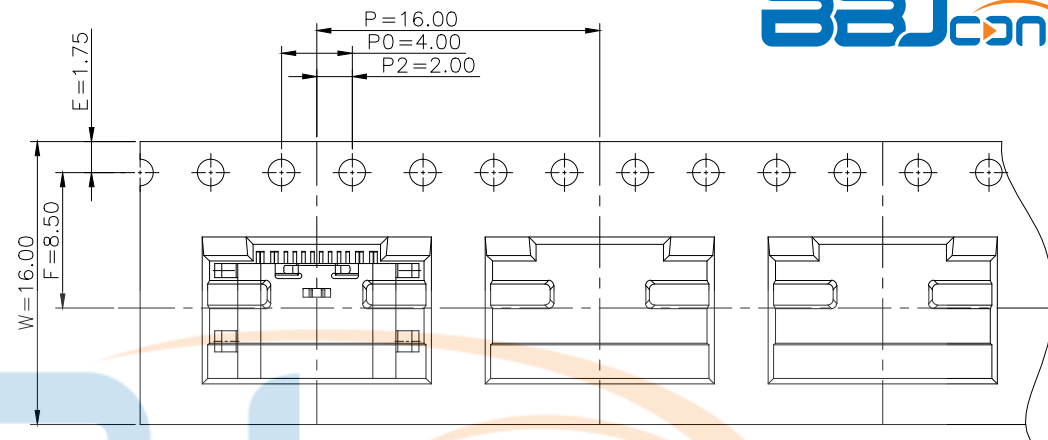
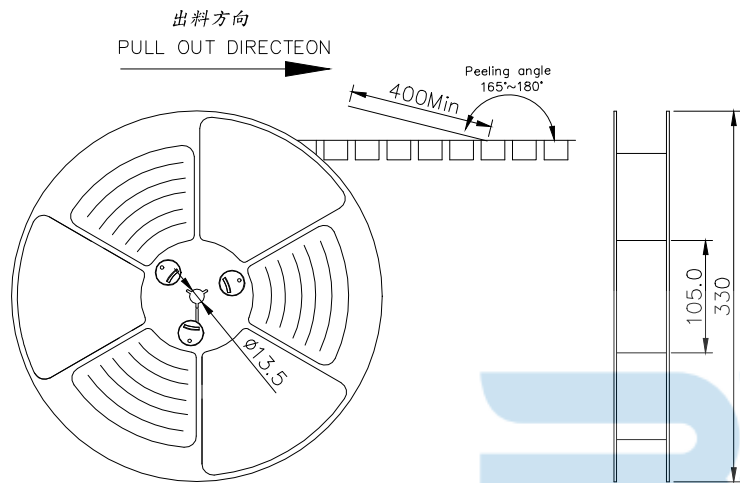

NOTES

1.帶子引導長度
LEAD TAPE LENGTH

出料方向
PULL OUT DIRECTEON

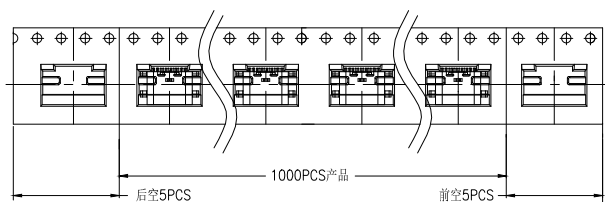

2.上帶 剝力力為：0.1~1.3N(10.2gf~130gf)
PEELING OFF FORCE OF TOP TAPE:0.1~1.3N(10.2gf~130gf)

出貨運輸過程中一定注意：
THIS REQUIREMENT SHOULD BE APPLIED AT SHIPMENT：
卷帶在運輸過程中不能散開
PEELING OFF SHOULD NOT BE ALLOWED DURING TRANSPORTATION

TAPE & REEL 14 PCS

1 REEL
= 1000 PCS

BOX

DIMENSIONS:
33.5X33.5X30.5

1 CARTON
=14 REELS
=14000 PCS

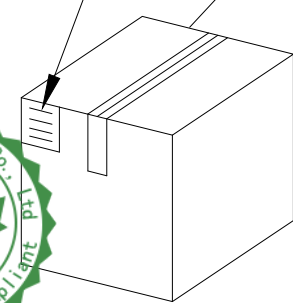
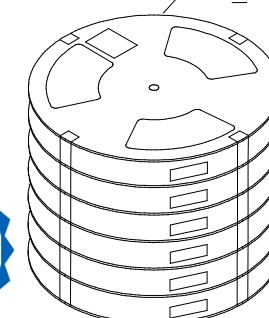

TOLERANCE UNSPECIFIED	
.0	±0.35
.00	±0.25
.000	±0.15
X.°	±2.00°
CUSTOMER DRAWING	
DRAWN/ DATE	HMY
CHECKED/ DATE	LYX
APPROVED/ DATE	LJP

深圳市步步精科技有限公司 TITLE: TYPE-C 16P 母座L=6.5沉板0.8 CH0.78			
SIZE:A4	UNIT:MM.	PART. NO: UC.01.31-11-0005	
SCALE: 1:1		PROJECTION	REV.: 版本
DWG. PATH		0100-2	SHEET: 页码

包裝明細表 (The detail of the packing) Carton						
產品料號 (Product No.)	包裝容量 (Packing Capacity)			重量 Weight (Kg)		
	pcs/box	boxes/Carton	Pcs/Box	N.W./Pcs	N.W./Box	G.W./Box
	1000	14	14000	----	----	----