

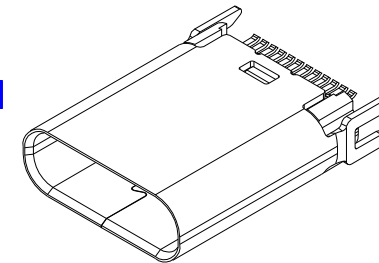

P/N:	DIM A	DIM B	DIM C	DIM D	DIM E
	10.50	1.00	1.00	12.15	6.20
	10.50	0.80	0.80	12.15	6.20
	10.50	0.80	1.00	12.15	6.20
	9.30	1.00	1.00	10.95	5.00
	9.30	0.80	0.80	10.95	5.00
	8.80	1.00	1.00	10.45	4.50
	8.80	0.80	0.80	10.45	4.50

REV.	ECN. NO.	NAME	DATE
C	新增规格		
D	新增规格		



NOTES:

1.MATERIAL:

MOLDING: LCP UL94 V-0

CONTACT: COPPER ALLOY.

GOLD PLATING ALL OVER 50u" Min NICKEL  
AND 100u" Min Tin ALL OVER 50u" Min NICKEL  
ON SOLDER AREA

SHELL: SUS304-H,T=0.30±0.03mm

50u" NICKEL PLATING OVER ALL.

SHILD: SUS304-H,T=0.12±0.03mm

2.MECHANICAL:

INSERTION: 5~20N.

EXTRACTION: 8~20N.

DURABILITY: 10000 CYCLES

3.ELECTRICAL:

CURRENT: 5A FOR VBUS;

1.25A FOR GND PIN.

0.25A FOR OTHER.

VOLTAGE: 20 V MAX

WITHSTANDING VOLTAGE: 100V AC.

CONTACT RESISTANCE: 40mΩ MAX.

INSULATION RESISTANCE: 100MΩ MIN.

4.ENVIRONMENTAL

TEMPERATURE RANGE -55°C ~ +85°C

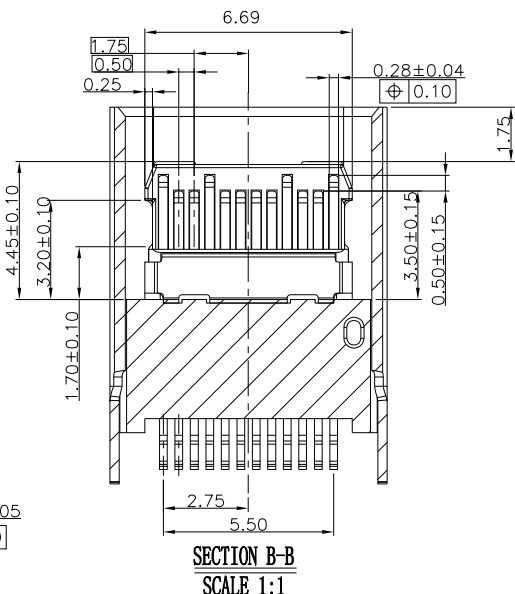
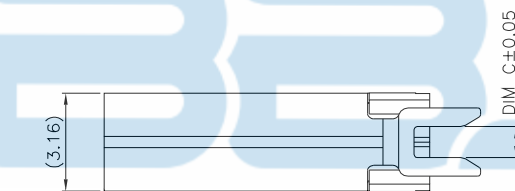
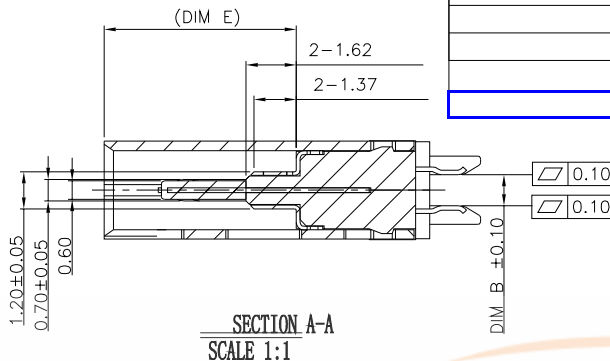
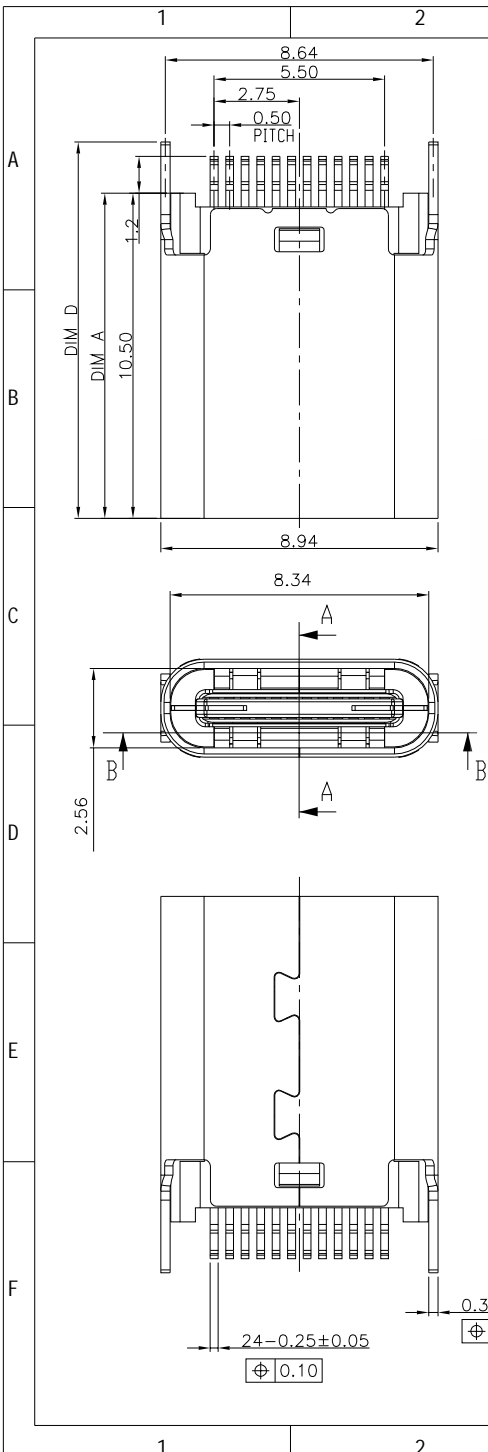

TOLERANCE	UNSPECIFIED
.0	±0.50
.0	±0.35
.00	±0.25
.000	±0.15
ANGLE	±3.00°
CUSTOMER DRAWING	

深圳市步步精科技有限公司

TITLE: TYPE-C 24P 母座 夹板式0.8 H=8.8

DRAWN BY:	HMY	SIZE: A4	UNIT: mm.	PART NO.	UC.01.72-46-0005
CHECKED BY:	LYX	SCALE: 1:1	PROJECTION		REV.: D
APPROVED BY:	LJP	DWG. PATH	0285-1	SHEET: 1/3	

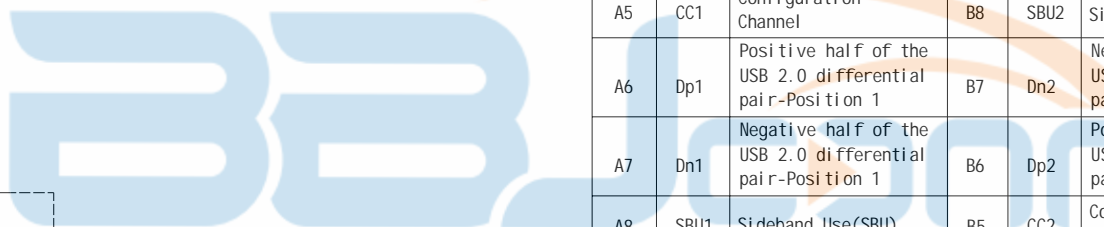

USB TYPE-C FULL-FEATURED RECEPTACLE INTERFACE PIN ASSIGNMENTS

PIN	Signal Name	Description	PIN	Signal Name	Description
A1	GND	Ground return	B12	GND	Ground return
A2	SSTXp1	Positive half of first SuperSpeed TX differential pair	B11	SSRXp1	Positive half of first SuperSpeed RX differential pair
A3	SSTXn1	Negative half of first SuperSpeed TX differential pair	B10	SSRXn1	Negative half of first SuperSpeed RX differential pair
A4	Vbus	Bus Power	B9	Vbus	Bus Power
A5	CC1	Configuration Channel	B8	SBU2	Sideband Use (SBU)
A6	Dp1	Positive half of the USB 2.0 differential pair-Position 1	B7	Dn2	Negative half of the USB 2.0 differential pair-Position 2
A7	Dn1	Negative half of the USB 2.0 differential pair-Position 1	B6	Dp2	Positive half of the USB 2.0 differential pair-Position 2
A8	SBU1	Sideband Use(SBU)	B5	CC2	Configuraation Channel
A9	Vbus	Bus Power	B4	Vbus	Bus Power
A10	SSRXn2	Negative half of second SuperSpeed RX differential pair	B3	SSTXn2	Negative half of second SuperSpeed TX differential pair
A11	SSRXp2	Positive half of second SuperSpeed RX differential pair	B2	SSTXp2	Positive half of second SuperSpeed TX differential pair
A12	GND	Ground return	B1	GND	Ground return

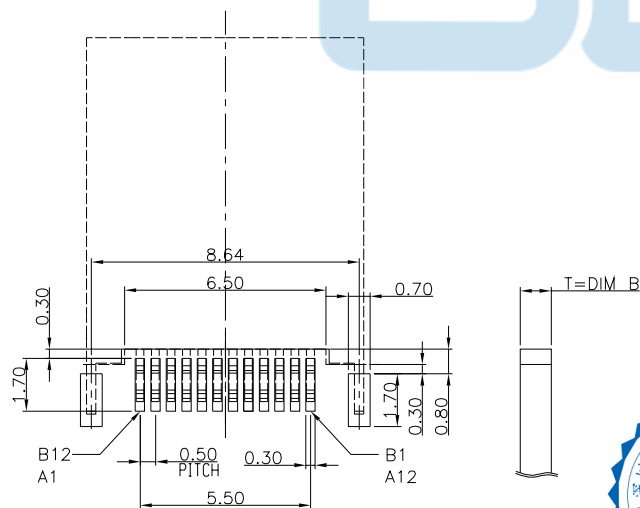

RECOMMENDED P.C.B. LAYOUT  
TOLERANCE UNSPECIFIED ±0.05mm



TOLERANCE UNSPECIFIED		<h1>深圳市步步精科技有限公司</h1>	
.	±0.50		
.0	±0.35	<b>TITLE: TYPE-C 24P 母座 夹板式0.8 H=8.8</b>	
.00	±0.25		
.000	±0.15	DRAWN BY: HMY	
ANGLE	±3.00°	SIZE: A4	UNIT: mm.
CUSTOMER DRAWING		PART NO.	UC.01.72-46-0005
CHECKED BY: LYX	SCALE: 1:1	PROJECTION	REV.: D
APPROVED BY: LJP	DWG. PATH	0285-1	SHEET: 2/3



一. 將成品依同一方向放入真空盤內,如圖所示。  
At same direction, put product onto the tray. Direction refers to below drawing.

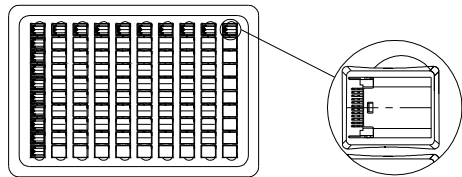

VIEW-1

二. 1) 一只紙箱可放置之包裝盤(包括上蓋)見下表。  
1) trays per carton, please see next table.

2) 每1個紙箱用的包裝數量詳見下表。

2) The Qty of products per carton please see next table.

3) 將裝滿成品的真空盤用 PE帶捆緊後放在塑膠袋內(10盤一捆),裝完後再封箱。

3) Bind the trays with PE tape and then (a bundle of 10 trays), put them into the poly bag. Seal the carton with tape.

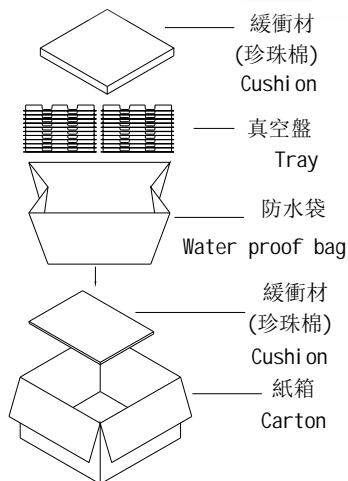

VIEW-2

三.

1) 將標籤貼於紙箱側麥上方。  
Stick the needful label On the up-right corner of the side of carton.

標籤黏貼處  
Location of Sticking lable

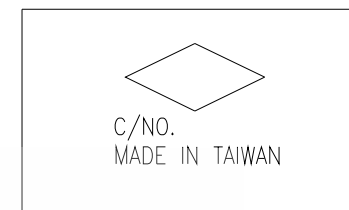
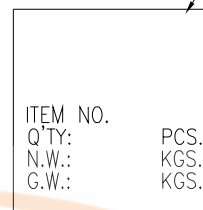

VIEW-3

備註(REMARK)

- 若有未裝滿之零數箱,必須以緩衝材塞滿。  
The unfilling-carton must be filled with assuagement.
- 防水袋需用膠帶貼實且封口。  
waterproof plastic bag must be folded up.
- 裝滿成品后之外箱,最大堆積箱數:5箱  
About the box fully filled with products, the MAX accumulating quantity of boxes is 5.
- 如須貼Bar-code,請依Bar-code作業辦法執行  
If barcode lable is required,do it according to the related barcode lable operation standards.



TOLERANCE UNSPECIFIED	±0.50
.0	±0.35
.00	±0.25
.000	±0.15
ANGLE	±3.00°
CUSTOMER DRAWING	
DRAWN BY:	HMY
CHECKED BY:	LYX
APPROVED BY:	LJP

深圳市步步精科技有限公司

TITLE: TYPE-C 24P 母座 夾板式0.8 H=8.8

包裝明細表 (The detail of the packing)						
產品料號 (Product No.)	包裝容量 (Packing Capacity)			重量 Weight (Kg)		
	pcs/box	boxs/Carton	Pcs/Box	N.W./Pcs	N.W./Box	G.W./Box
	100	60	6000			

SIZE: A4	UNIT: mm.	PART NO.	UC.01.72-46-0005	
SCALE: 1:1	PROJECTION			REV.: D
DWG. PATH	0285-1	SHEET: 3/3		