

XD2551 DIP8 / XL2551 SOP8

Features

- Suitable for 12V and 24V systems
- Externally-controlled slope for reduced RFI emissions
- Detection of ground fault (permanent Dominant) on TXD input
- Power-on Reset and voltage brown-out protection
- An unpowered node or brown-out event will not disturb the CAN bus
- Low current standby operation
- Protection against damage due to short-circuit conditions (positive or negative battery voltage)
- Protection against high-voltage transients
- Automatic thermal shutdown protection
- Up to 112 nodes can be connected
- High-noise immunity due to differential bus implementation
- Temperature ranges:
 - Industrial (I): -40°C to +85°C
 - Extended (E): -40°C to +125°C

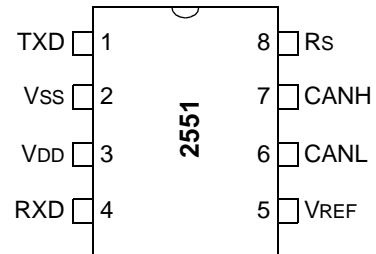

Block Diagram

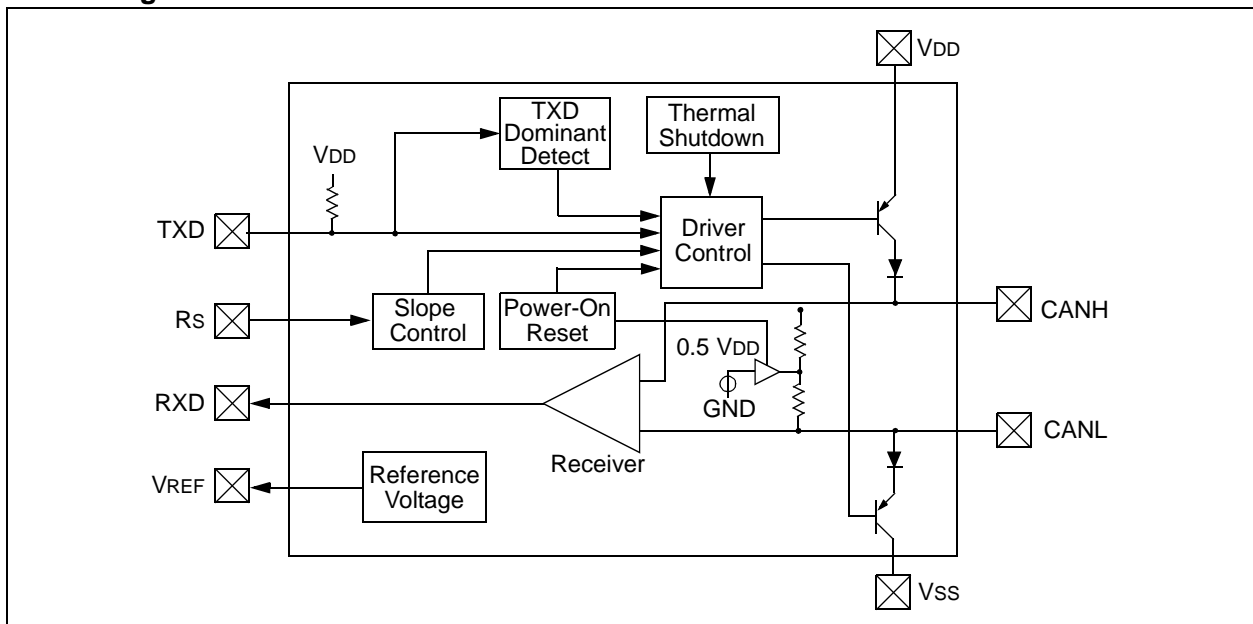

TABLE 1-1: MODES OF OPERATION

Mode	Current at R _S Pin	Resulting Voltage at R _S Pin
Standby	-I _{RS} < 10 μA	V _{RS} > 0.75 V _{DD}
Slope-Control	10 μA < -I _{RS} < 200 μA	0.4 V _{DD} < V _{RS} < 0.6 V _{DD}
High-Speed	-I _{RS} < 610 μA	0 < V _{RS} < 0.3V _{DD}

TABLE 1-2: TRANSCEIVER TRUTH TABLE

V _{DD}	V _{RS}	TXD	CANH	CANL	Bus State ⁽¹⁾	RxD ⁽¹⁾
4.5V ≤ V _{DD} ≤ 5.5V	V _{RS} < 0.75 V _{DD}	0	HIGH	LOW	Dominant	0
		1 or floating	Not Driven	Not Driven	Recessive	1
	V _{RS} > 0.75 V _{DD}	X	Not Driven	Not Driven	Recessive	1
V _{POR} < V _{DD} < 4.5V (See Note 3)	V _{RS} < 0.75 V _{DD}	0	HIGH	LOW	Dominant	0
		1 or floating	Not Driven	Not Driven	Recessive	1
	V _{RS} > 0.75 V _{DD}	X	Not Driven	Not Driven	Recessive	1
0 < V _{DD} < V _{POR}	X	X	Not Driven/ No Load	Not Driven/ No Load	High Impedance	X

- Note 1:** If another bus node is transmitting a Dominant bit on the CAN bus, then RxD is a logic '0'.
Note 2: X = "don't care".
Note 3: Device drivers will function, although outputs are not ensured to meet the ISO-11898 specification.

FIGURE 1-1: SLEW RATE VS. SLOPE-CONTROL RESISTANCE VALUE

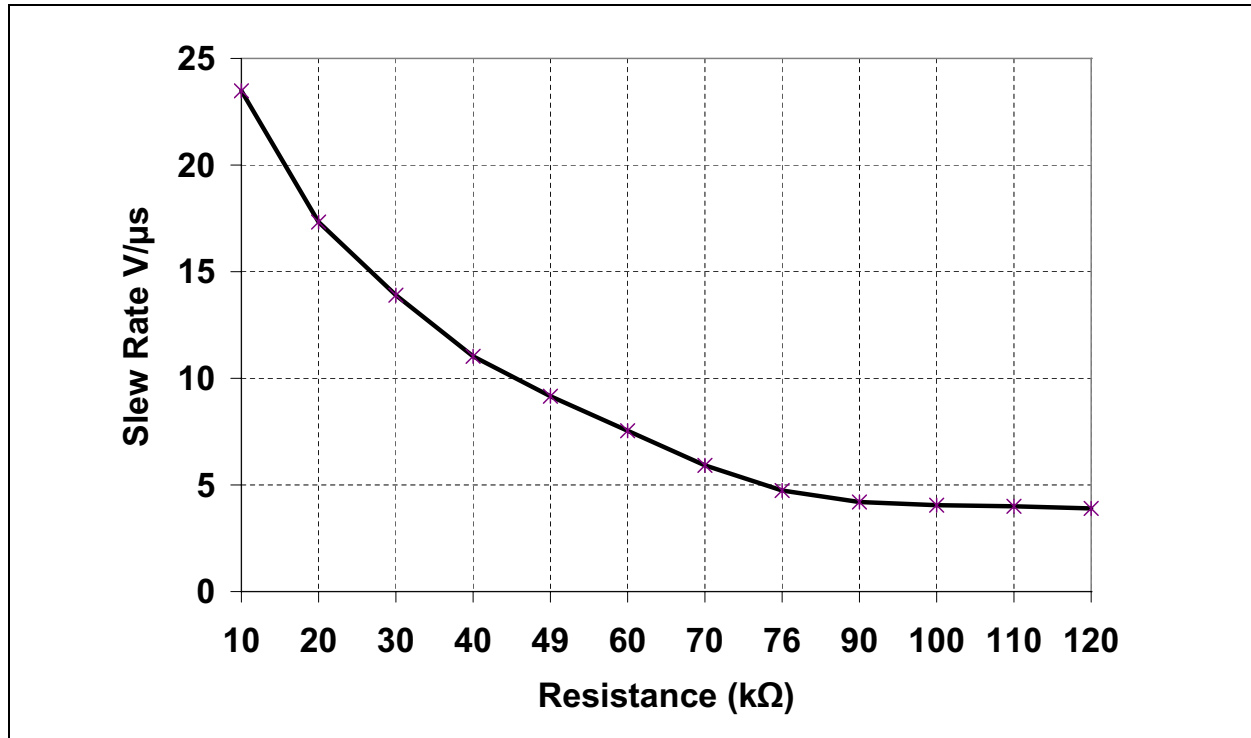

1.0 TXD Permanent Dominant Detection

If the 2551 detects an extended Low state on the TXD input, it will disable the CANH and CANL output drivers in order to prevent the corruption of data on the CAN bus. The drivers are disabled if TXD is Low for more than 1.25 ms (minimum). This implies a maximum bit time of 62.5 μ s (16 kb/s bus rate), allowing up to 20 consecutive transmitted Dominant bits during a multiple bit error and error frame scenario. The drivers remain disabled as long as TXD remains Low. A rising edge on TXD will reset the timer logic and enable the CANH and CANL output drivers.

1.1 Power-on Reset

When the device is powered on, CANH and CANL remain in a high-impedance state until VDD reaches the voltage-level VPORH. In addition, CANH and CANL will remain in a high-impedance state if TXD is Low when VDD reaches VPORH. CANH and CANL will become active only after TXD is asserted High. Once powered on, CANH and CANL will enter a high-impedance state if the voltage level at VDD falls below VPORL, providing voltage brown-out protection during normal operation.

1.2 Pin Descriptions

The 8-pin pinout is listed in Table 1-3.

TABLE 1-3: MCP2551 PINOUT

Pin Number	Pin Name	Pin Function
1	TXD	Transmit Data Input
2	VSS	Ground
3	VDD	Supply Voltage
4	RXD	Receive Data Output
5	VREF	Reference Output Voltage
6	CANL	CAN Low-Level Voltage I/O
7	CANH	CAN High-Level Voltage I/O
8	Rs	Slope-Control Input

1.2.1 TRANSMITTER DATA INPUT (TXD)

TXD is a TTL-compatible input pin. The data on this pin is driven out on the CANH and CANL differential output pins. It is usually connected to the transmitter data output of the CAN controller device. When TXD is Low, CANH and CANL are in the Dominant state. When TXD is High, CANH and CANL are in the Recessive state, provided that another CAN node is not driving the CAN bus with a Dominant state. TXD has an internal pull-up resistor (nominal 25 k Ω to VDD).

1.2.2 GROUND SUPPLY (VSS)

Ground supply pin.

1.2.3 SUPPLY VOLTAGE (VDD)

Positive supply voltage pin.

1.2.4 RECEIVER DATA OUTPUT (RXD)

RXD is a CMOS-compatible output that drives High or Low depending on the differential signals on the CANH and CANL pins and is usually connected to the receiver data input of the CAN controller device. RXD is High when the CAN bus is Recessive and Low in the Dominant state.

1.2.5 REFERENCE VOLTAGE (VREF)

Reference Voltage Output (defined as VDD/2).

1.2.6 CAN LOW (CANL)

The CANL output drives the Low side of the CAN differential bus. This pin is also tied internally to the receive input comparator.

1.2.7 CAN HIGH (CANH)

The CANH output drives the high-side of the CAN differential bus. This pin is also tied internally to the receive input comparator.

1.2.8 SLOPE RESISTOR INPUT (Rs)

The Rs pin is used to select High-Speed, Slope-Control or Standby modes via an external biasing resistor.

2.0 ELECTRICAL CHARACTERISTICS

2.1 Terms and Definitions

A number of terms are defined in ISO-11898 that are used to describe the electrical characteristics of a CAN transceiver device. These terms and definitions are summarized in this section.

2.1.1 BUS VOLTAGE

V_{CANL} and V_{CANH} denote the voltages of the bus line wires CANL and CANH relative to ground of each individual CAN node.

2.1.2 COMMON MODE BUS VOLTAGE RANGE

Boundary voltage levels of V_{CANL} and V_{CANH} with respect to ground, for which proper operation will occur, if up to the maximum number of CAN nodes are connected to the bus.

2.1.3 DIFFERENTIAL INTERNAL CAPACITANCE, C_{DIFF} (OF A CAN NODE)

Capacitance seen between CANL and CANH during the Recessive state when the CAN node is disconnected from the bus (see Figure 2-1).

2.1.4 DIFFERENTIAL INTERNAL RESISTANCE, R_{DIFF} (OF A CAN NODE)

Resistance seen between CANL and CANH during the Recessive state when the CAN node is disconnected from the bus (see Figure 2-1).

2.1.5 DIFFERENTIAL VOLTAGE, V_{DIFF} (OF CAN BUS)

Differential voltage of the two-wire CAN bus, value $V_{DIFF} = V_{CANH} - V_{CANL}$.

2.1.6 INTERNAL CAPACITANCE, C_{IN} (OF A CAN NODE)

Capacitance seen between CANL (or CANH) and ground during the Recessive state when the CAN node is disconnected from the bus (see Figure 2-1).

2.1.7 INTERNAL RESISTANCE, R_{IN} (OF A CAN NODE)

Resistance seen between CANL (or CANH) and ground during the Recessive state when the CAN node is disconnected from the bus (see Figure 2-1).

FIGURE 2-1: PHYSICAL LAYER DEFINITIONS

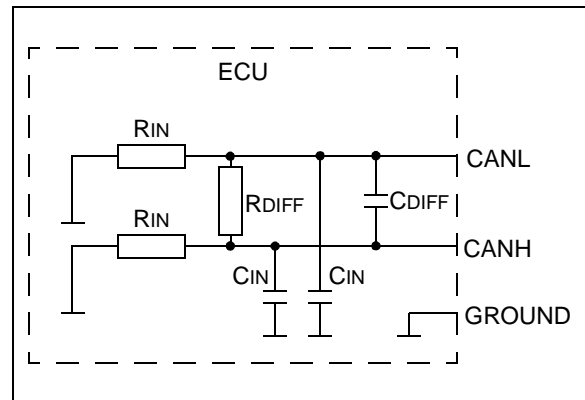

Absolute Maximum Ratings†

VDD.....	7.0V
DC Voltage at TXD, RXD, VREF and VS.....	-0.3V to VDD + 0.3V
DC Voltage at CANH, CANL (Note 1).....	-42V to +42V
Transient Voltage on Pins 6 and 7 (Note 2).....	-250V to +250V
Storage temperature	-55°C to +150°C
Operating ambient temperature	-40°C to +125°C
Virtual Junction Temperature, TVJ (Note 3).....	-40°C to +150°C
Soldering temperature of leads (10 seconds)	+300°C
ESD protection on CANH and CANL pins (Note 4)	6 kV
ESD protection on all other pins (Note 4)	4 kV

Note 1: Short-circuit applied when TXD is High and Low.

2: In accordance with ISO-7637.

3: In accordance with IEC 60747-1.

4: Classification A: Human Body Model.

XD2551 DIP8 / XL2551 SOP8

2.2 DC Characteristics

DC Specifications			Electrical Characteristics:			
			Industrial (I): T _{AMB} = -40°C to +85°C V _{DD} = 4.5V to 5.5V			
			Extended (E): T _{AMB} = -40°C to +125°C V _{DD} = 4.5V to 5.5V			
Param No.	Sym	Characteristic	Min	Max	Units	Conditions
Supply						
D1	IDD	Supply Current	—	75	mA	Dominant; V _{TXD} = 0.8V; V _{DD}
D2			—	10	mA	Recessive; V _{TXD} = +2V; R _S = 47 kΩ
D3			—	365	μA	-40°C ≤ T _{AMB} ≤ +85°C, Standby; (Note 2)
			—	465	μA	-40°C ≤ T _{AMB} ≤ +125°C, Standby; (Note 2)
D4	V _{PORH}	High-level of the Power-on Reset comparator	3.8	4.3	V	CANH, CANL outputs are active when V _{DD} > V _{PORH}
D5	V _{PORL}	Low-level of the Power-on Reset comparator	3.4	4.0	V	CANH, CANL outputs are not active when V _{DD} < V _{PORL}
D6	V _{PORD}	Hysteresis of Power-on Reset comparator	0.3	0.8	V	Note 1
Bus Line (CANH; CANL) Transmitter						
D7	V _{CANH(r)} ; V _{CANL(r)}	CANH, CANL Recessive bus voltage	2.0	3.0	V	V _{TXD} = V _{DD} ; no load.
D8	I _O (CANH)(reces) I _O (CANL)(reces)	Recessive output current	-2	+2	mA	-2V < V(CAHL,CANH) < +7V, 0V < V _{DD} < 5.5V
D9			-10	+10	mA	-5V < V(CANL,CANH) < +40V, 0V < V _{DD} < 5.5V
D10	V _O (CANH)	CANH Dominant output voltage	2.75	4.5	V	V _{TXD} = 0.8V
D11	V _O (CANL)	CANL Dominant output voltage	0.5	2.25	V	V _{TXD} = 0.8V
D12	V _{DIFF(r)(o)}	Recessive differential output voltage	-500	+50	mV	V _{TXD} = 2V; no load
D13	V _{DIFF(d)(o)}	Dominant differential output voltage	1.5	3.0	V	V _{TXD} = 0.8V; V _{DD} = 5V 40W < R _L < 60W (Note 2)
D14	I _O (SC)(CANH)	CANH short-circuit output current	—	-200	mA	V _{CANH} = -5V
D15			—	-100 (typical)	mA	V _{CANH} = -40V, +40V. (Note 1)
D16	I _O (SC)(CANL)	CANL short-circuit output current	—	200	mA	V _{CANL} = -40V, +40V. (Note 1)
D17	V _{DIFF(r)(i)}	Recessive differential input voltage	-1.0	+0.5	V	-2V < V(CANL, CANH) < +7V (Note 3)
			-1.0	+0.4	V	-12V < V(CANL, CANH) < +12V (Note 3)

Note 1: This parameter is periodically sampled and not 100% tested.

2: I_{TXD} = I_{RXD} = I_{VREF} = 0 mA; 0V < V_{CANL} < V_{DD}; 0V < V_{CANH} < V_{DD}; V_{RS} = V_{DD}.

3: This is valid for the receiver in all modes; High-speed, Slope-control and Standby.

2.2 DC Characteristics (Continued)

DC Specifications (Continued)			Electrical Characteristics:			
			Industrial (I): T _{AMB} = -40°C to +85°C V _{DD} = 4.5V to 5.5V			
			Extended (E): T _{AMB} = -40°C to +125°C V _{DD} = 4.5V to 5.5V			
Param No.	Sym	Characteristic	Min	Max	Units	Conditions
Bus Line (CANH; CANL) Receiver: [TXD = 2V; pins 6 and 7 externally driven]						
D18	V _{DIFF(d)(i)}	Dominant differential input voltage	0.9	5.0	V	-2V < V(CANL, CANH) < +7V (Note 3)
			1.0	5.0	V	-12V < V(CANL, CANH) < +12V (Note 3)
D19	V _{DIFF(h)(i)}	Differential input hysteresis	100	200	mV	See Figure 2-3 (Note 1)
D20	R _{IN}	CANH, CANL Common-mode input resistance	5	50	kΩ	
D21	R _{IN(d)}	Deviation between CANH and CANL Common-mode input resistance	-3	+3	%	V _{CANH} = V _{CANL}
Bus Line (CANH; CANL) Receiver: [TXD = 2V; pins 6 and 7 externally driven]						
D22	R _{DIFF}	Differential input resistance	20	100	kΩ	
D24	I _{LI}	CANH, CANL input leakage current	—	150	μA	V _{DD} < V _{POR} ; V _{CANH} = V _{CANL} = +5V
Transmitter Data Input (TXD)						
D25	V _{IH}	High-level input voltage	2.0	V _{DD}	V	Output Recessive
D26	V _{IL}	Low-level input voltage	V _{SS}	+0.8	V	Output Dominant
D27	I _{IH}	High-level input current	-1	+1	μA	V _{TXD} = V _{DD}
D28	I _{IL}	Low-level input current	-100	-400	μA	V _{TXD} = 0V
Receiver Data Output (RXD)						
D31	V _{OH}	High-level output voltage	0.7 V _{DD}	—	V	I _{OH} = 8 mA
D32	V _{OL}	Low-level output voltage	—	0.8	V	I _{OL} = 8 mA
Voltage Reference Output (VREF)						
D33	V _{REF}	Reference output voltage	0.45 V _{DD}	0.55 V _{DD}	V	-50 μA < I _{VREF} < 50 μA
Standby/Slope-Control (Rs pin)						
D34	V _{STB}	Input voltage for standby mode	0.75 V _{DD}	—	V	
D35	I _{SLOPE}	Slope-control mode current	-10	-200	μA	
D36	V _{SLOPE}	Slope-control mode voltage	0.4 V _{DD}	0.6 V _{DD}	V	
Thermal Shutdown						
D37	T _{J(sd)}	Shutdown junction temperature	155	180	°C	Note 1
D38	T _{J(h)}	Shutdown temperature hysteresis	20	30	°C	-12V < V(CANL, CANH) < +12V (Note 3)

Note 1: This parameter is periodically sampled and not 100% tested.

2: I_{TXD} = I_{RXD} = I_{VREF} = 0 mA; 0V < V_{CANL} < V_{DD}; 0V < V_{CANH} < V_{DD}; V_{RS} = V_{DD}.

3: This is valid for the receiver in all modes; High-speed, Slope-control and Standby.

FIGURE 2-1: TEST CIRCUIT FOR ELECTRICAL CHARACTERISTICS

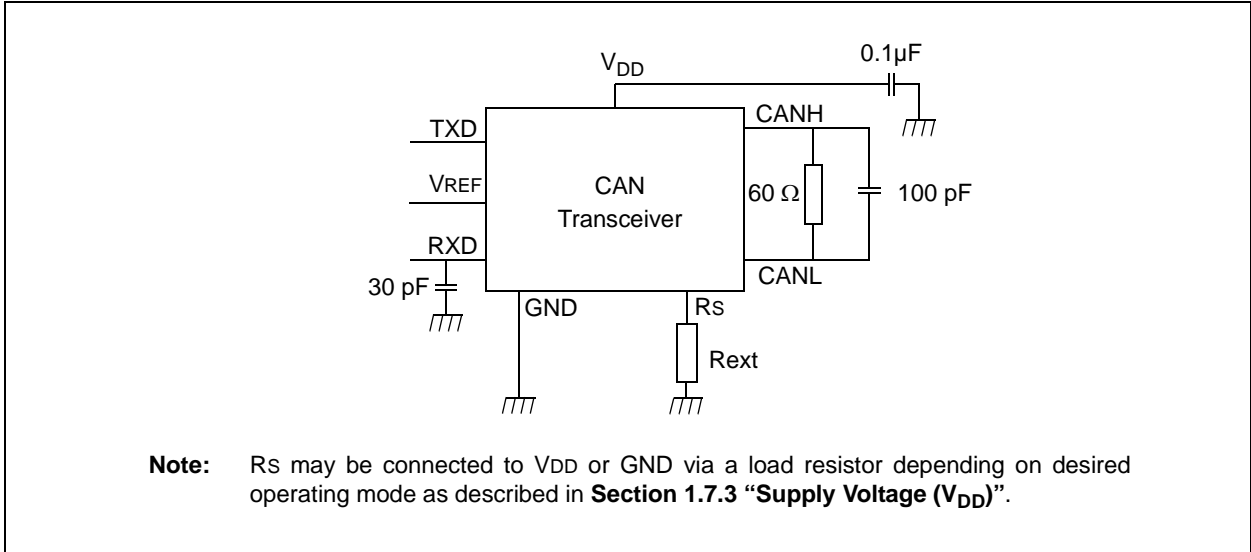

FIGURE 2-2: TEST CIRCUIT FOR AUTOMOTIVE TRANSIENTS

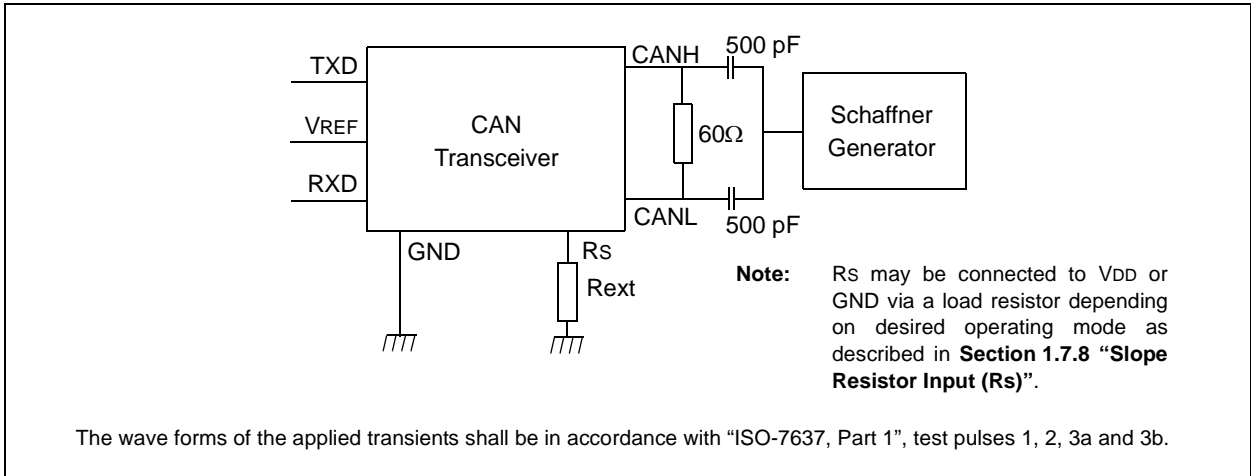
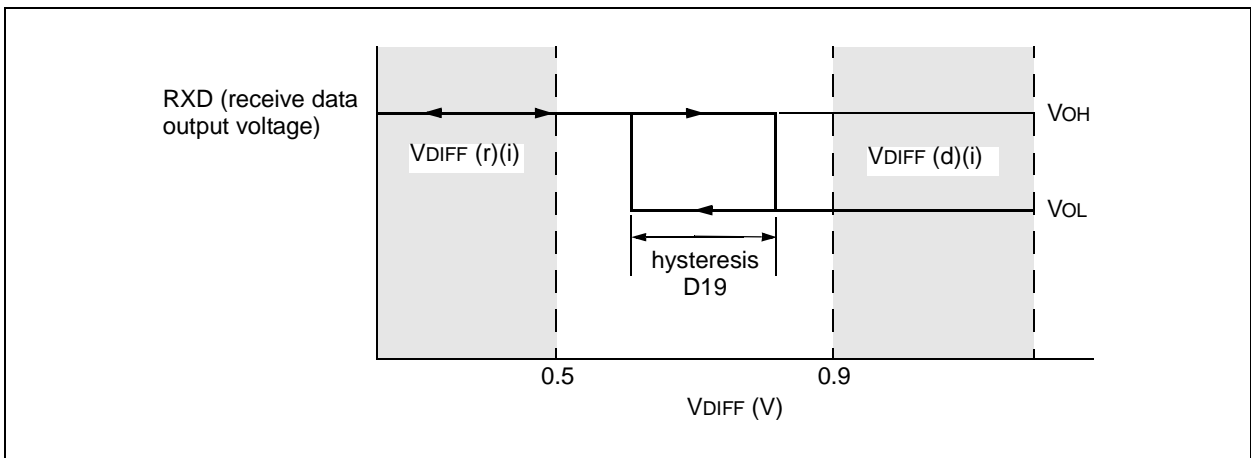

FIGURE 2-3: HYSTERESIS OF THE RECEIVER



2.3 AC Characteristics

AC Specifications			Electrical Characteristics: Industrial (I): T _{AMB} = -40°C to +85°C V _{DD} = 4.5V to 5.5V Extended (E): T _{AMB} = -40°C to +125°C V _{DD} = 4.5V to 5.5V			
Param No.	Sym	Characteristic	Min	Max	Units	Conditions
1	tBIT	Bit time	1	62.5	μs	VRS = 0V
2	fBIT	Bit frequency	16	1000	kHz	VRS = 0V
3	TtxL2bus(d)	Delay TXD to bus active	—	70	ns	-40°C ≤ T _{AMB} ≤ +125°C, VRS = 0V
4	TtxH2bus(r)	Delay TXD to bus inactive	—	125	ns	-40°C ≤ T _{AMB} ≤ +85°C, VRS = 0V
			—	170	ns	-40°C ≤ T _{AMB} ≤ +125°C, VRS = 0V
5	TtxL2rx(d)	Delay TXD to receive active	—	130	ns	-40°C ≤ T _{AMB} ≤ +125°C, VRS = 0V
			—	250	ns	-40°C ≤ T _{AMB} ≤ +125°C, R _S = 47 kΩ
6	TtxH2rx(r)	Delay TXD to receiver inactive	—	175	ns	-40°C ≤ T _{AMB} ≤ +85°C, VRS = 0V
			—	225	ns	-40°C ≤ T _{AMB} ≤ +85°C, R _S = 47 kΩ
			—	235	ns	-40°C ≤ T _{AMB} ≤ +125°C, VRS = 0V
			—	400	ns	-40°C ≤ T _{AMB} ≤ +125°C, R _S = 47 kΩ
7	SR	CANH, CANL slew rate	5.5	8.5	V/μs	Refer to Figure 2-1 ; R _S = 47 kΩ, (Note 1)
10	tWAKE	Wake-up time from standby (R _S pin)	—	5	μs	See Figure 2-5
11	TbusD2rx(s)	Bus Dominant to RXD Low (Standby mode)	—	550	ns	VRS = +4V; (See Figure 2-6)
12	C _{IN} (CANH) C _{IN} (CANL)	CANH; CANL input capacitance	—	20 (typical)	pF	1 Mb/s data rate; V _{TXD} = V _{DD} , (Note 1)
13	C _{DIFF}	Differential input capacitance	—	10 (typical)	pF	1 Mb/s data rate (Note 1)
14	TtxL2busZ	TX Permanent Dominant Timer Disable Time	1.25	4	ms	
15	TtxR2pdt(res)	TX Permanent Dominant Timer Reset Time	—	1	μs	Rising edge on TXD while device is in permanent Dominant state

Note 1: This parameter is periodically sampled and not 100% tested.

2.4 Timing Diagrams and Specifications

FIGURE 2-4: TIMING DIAGRAM FOR AC CHARACTERISTICS

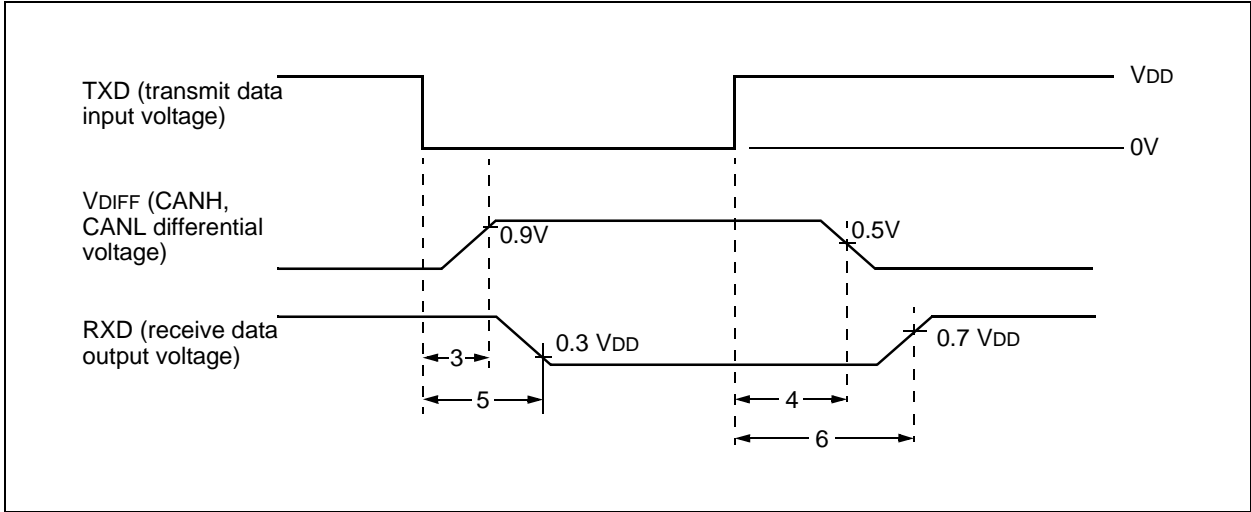

FIGURE 2-5: TIMING DIAGRAM FOR WAKE-UP FROM STANDBY

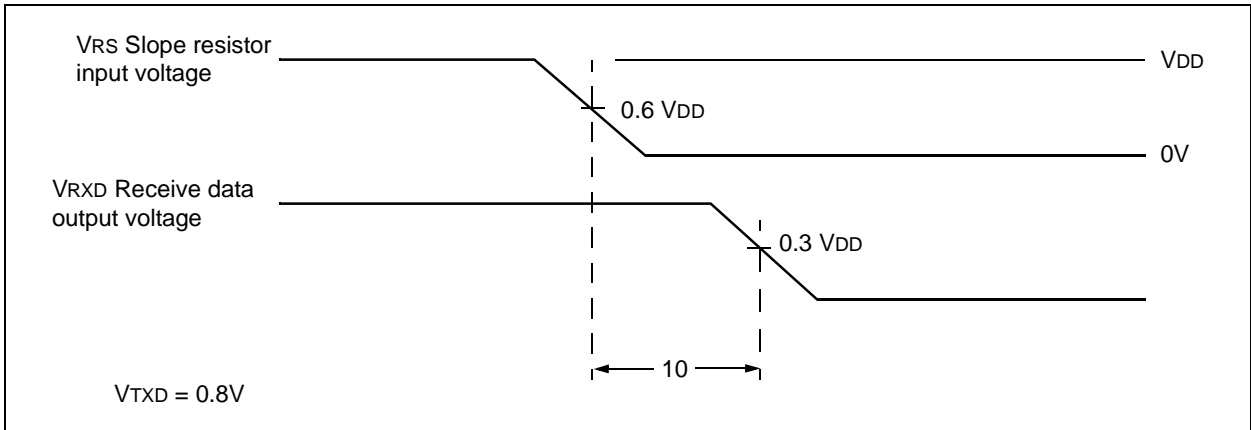
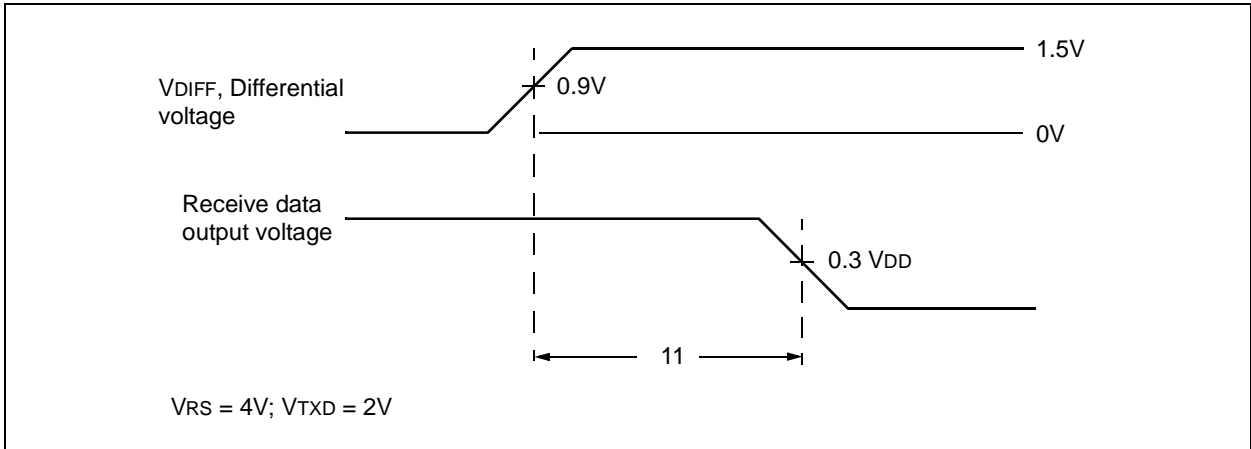
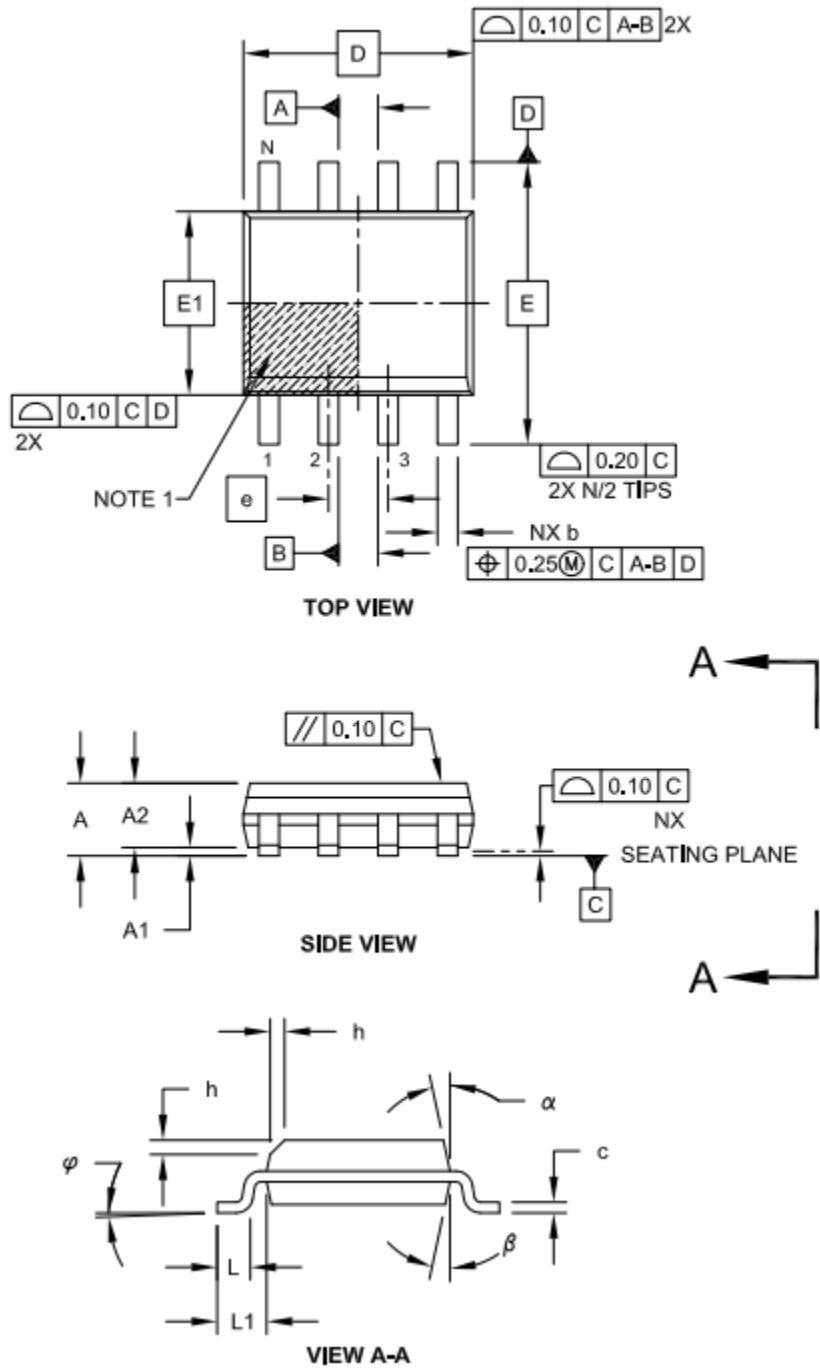

FIGURE 2-6: TIMING DIAGRAM FOR BUS DOMINANT TO RXD LOW (STANDBY MODE)



XD2551 DIP8 / XL2551 SOP8



XD2551 DIP8 / XL2551 SOP8

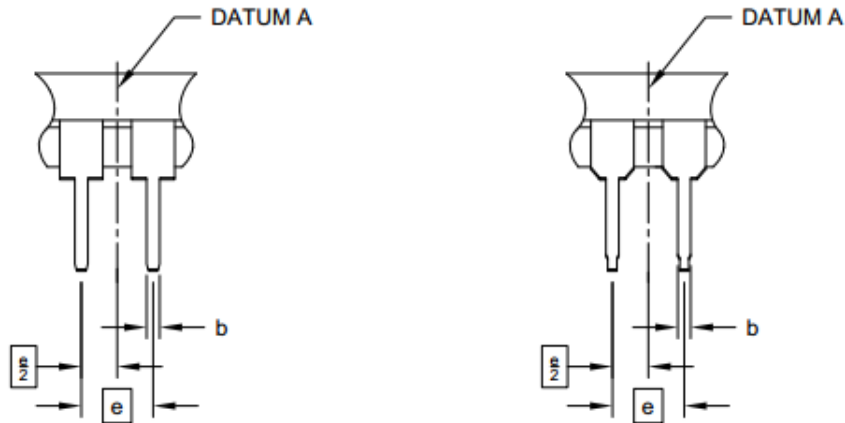
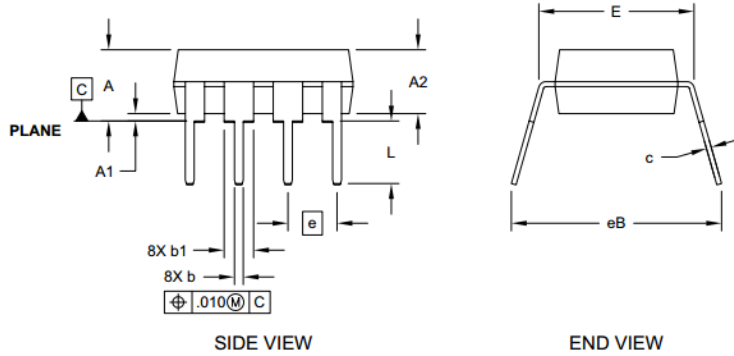
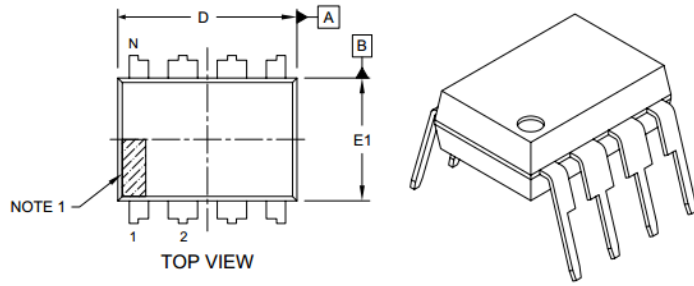

		Units	INCHES		
Dimension Limits			MIN	NOM	MAX
Number of Pins	N		8		
Pitch	e		.100 BSC		
Top to Seating Plane	A	-	-	-	.210
Molded Package Thickness	A2		.115	.130	.195
Base to Seating Plane	A1		.015	-	-
Shoulder to Shoulder Width	E		.290	.310	.325
Molded Package Width	E1		.240	.250	.280
Overall Length	D		.348	.365	.400
Tip to Seating Plane	L		.115	.130	.150
Lead Thickness	c		.008	.010	.015
Upper Lead Width	b1		.040	.060	.070
Lower Lead Width	b		.014	.018	.022
Overall Row Spacing	§ eB		-	-	.430

DEC.

以上信息仅供参考. 如需帮助联系客服人员。谢谢 XINLUDA