

## Description

- The WTM3401 uses advanced trench technology to provide excellent  $R_{DS(ON)}$ , low gate charge and operation with gate voltages as low as 2.5V. This device is suitable for use as a battery protection or in PWM application.

## Features

- $V_{DS} = -30V$ ,  $I_D = -4.2A$   
 $R_{DS(ON)} < 130m\Omega @ V_{GS} = -2.5V$   
 $R_{DS(ON)} < 75m\Omega @ V_{GS} = -4.5V$   
 $R_{DS(ON)} < 55m\Omega @ V_{GS} = -10V$
- High power and current handling capability
- Lead free product is acquired
- Surface mount package

## Application

- Battery protection.
- Load switch
- Power management

## Package and order information

Device	Device Marking	Device Package	Reel Size	Tape width	Quantity
WTM3401	A19T	SOT-23	Ø180mm	8 mm	3000 pcs

## Absolute Maximum Ratings (TA=25°C, RH=45%-75%, unless otherwise noted)

Parameter	Symbol	Value	Unit
Drain-Source Voltage	$V_{DS}$	-30	V
Gate-Source Voltage	$V_{GS}$	±12	V
Drain Current-Continuous	$I_D$	-4.2	A
Drain Current-Pulsed <sup>(Note 1)</sup>	$I_{DM}$	-30	A
Maximum Power Dissipation	$P_D$	1.2	W
Operating Junction and Storage Temperature Range	$T_J$ & $T_{STG}$	-55 to +150	°C

## Thermal Characteristic

Parameter	Symbol	Value	Unit
Thermal Resistance and Junction-to-Ambient <sup>(Note 2)</sup>	$R_{\theta JA}$	104	°C/W

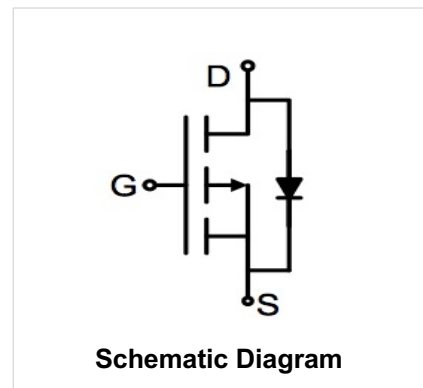

**Electrical Characteristics** (TA = 25°C unless otherwise noted)

Parameter	Symbol	Condition	Min	Typ	Max	Unit
<b>Off Characteristics</b>						
Drain-Source Breakdown Voltage	B <sub>VDS</sub>	V <sub>GS</sub> =0V, I <sub>D</sub> = -250μA	-30		-	V
Zero Gate Voltage Drain Current	I <sub>DSS</sub>	V <sub>DS</sub> =-24V, V <sub>GS</sub> =0V	-	-	-1	μA
Gate-Body Leakage Current	I <sub>GSS</sub>	V <sub>GS</sub> =±10V, V <sub>DS</sub> =0V	-	-	±100	nA
<b>On Characteristics</b> (Note 3)						
Gate Threshold Voltage	V <sub>GS(th)</sub>	V <sub>DS</sub> =V <sub>GS</sub> , I <sub>D</sub> = -250μA	-0.7	-1	-1.3	V
Drain-Source On-State Resistance	R <sub>DS(ON)</sub>	V <sub>GS</sub> =-10V, I <sub>D</sub> = -4.2A		48	55	mΩ
		V <sub>GS</sub> = -4.5V, I <sub>D</sub> = -4A	-	56	75	mΩ
		V <sub>GS</sub> = -2.5V, I <sub>D</sub> = -1A	-	72	130	mΩ
Forward Transconductance	g <sub>FS</sub>	V <sub>DS</sub> =-5V, I <sub>D</sub> =-4.2A		10	-	S
<b>Dynamic Characteristics</b> (Note4)						
Input Capacitance	C <sub>iss</sub>	V <sub>DS</sub> =-15V, V <sub>GS</sub> =0V, F=1.0MHz	-	880	-	PF
Output Capacitance	C <sub>oss</sub>		-	105	-	PF
Reverse Transfer Capacitance	C <sub>rss</sub>		-	65	-	PF
<b>Switching Characteristics</b> (Note 4)						
Turn-on Delay Time	t <sub>d(on)</sub>	V <sub>DD</sub> = -15V, I <sub>D</sub> = -4.2A V <sub>GS</sub> = -10V, R <sub>GEN</sub> = 6Ω	-	7	-	nS
Turn-on Rise Time	t <sub>r</sub>		-	3	-	nS
Turn-Off Delay Time	t <sub>d(off)</sub>		-	30	-	nS
Turn-Off Fall Time	t <sub>f</sub>		-	12	-	nS
Total Gate Charge	Q <sub>g</sub>	V <sub>DS</sub> =-15V, I <sub>D</sub> =-4.2A, V <sub>GS</sub> =-4.5V	-	8.5	-	nC
Gate-Source Charge	Q <sub>gs</sub>		-	1.8	-	nC
Gate-Drain Charge	Q <sub>gd</sub>		-	2.7	-	nC
<b>Drain-Source Diode Characteristics</b>						
Diode Forward Voltage (Note 3)	V <sub>SD</sub>	V <sub>GS</sub> =0V, I <sub>S</sub> = -4.2A	-	-	-1.2	V

Notes:

1. Repetitive Rating: Pulse width limited by maximum junction temperature.
2. Surface Mounted on FR4 Board, t ≤ 10 sec.
3. Pulse Test: Pulse Width ≤ 300μs, Duty Cycle ≤ 2%.
4. Guaranteed by design, not subject to production

Typical Electrical and Thermal Characteristics

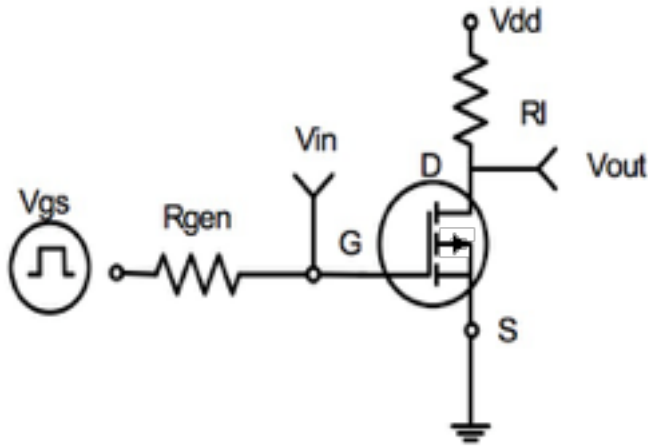

Figure 1 - Switching Test Circuit

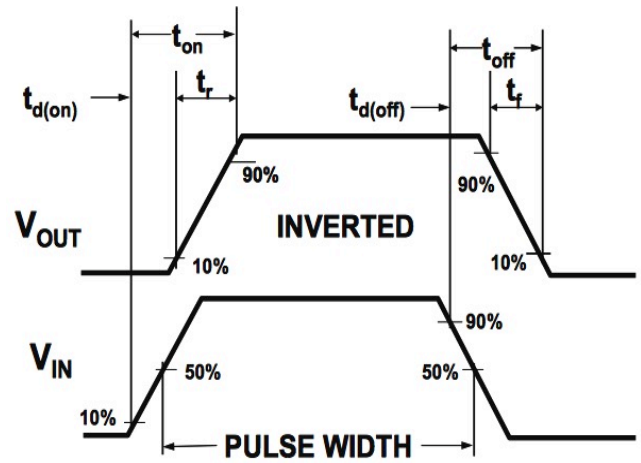

Figure 2 - Switching Waveforms

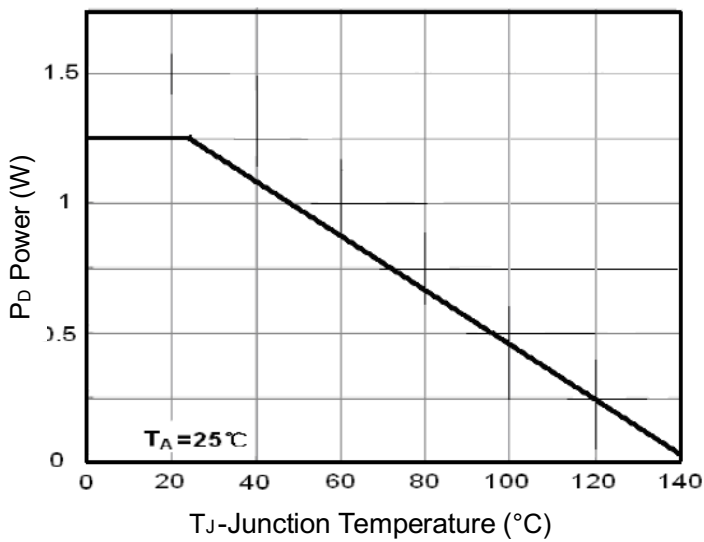

Figure 3 - Power Dissipation

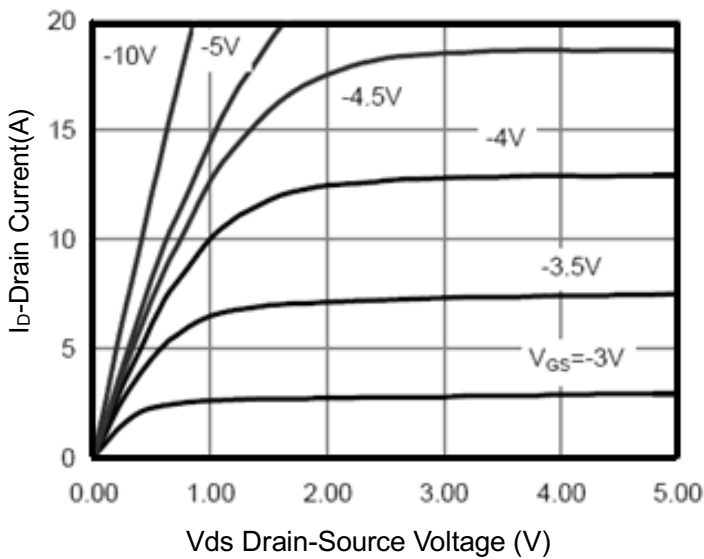
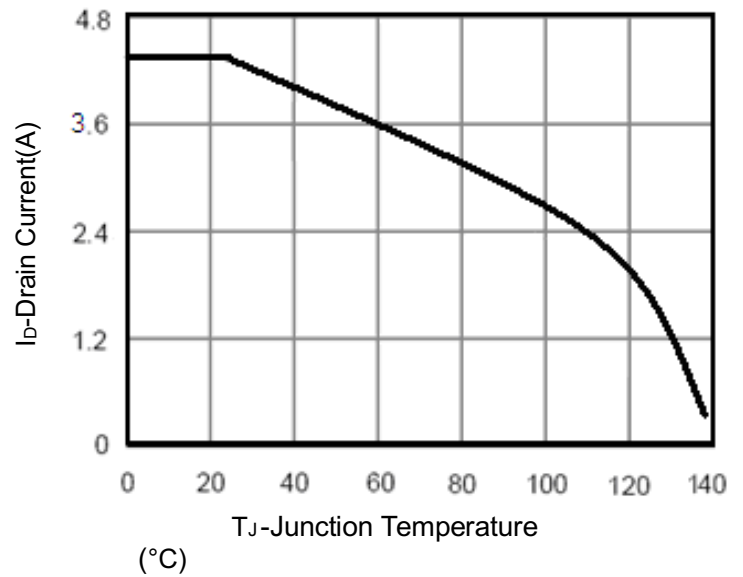

Figure 5 - Output Characteristics

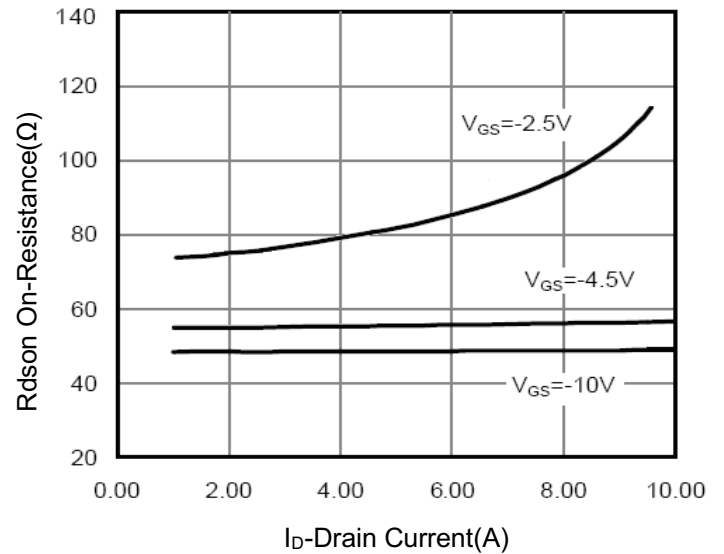

Figure 6 - Drain-Source On-Resistance

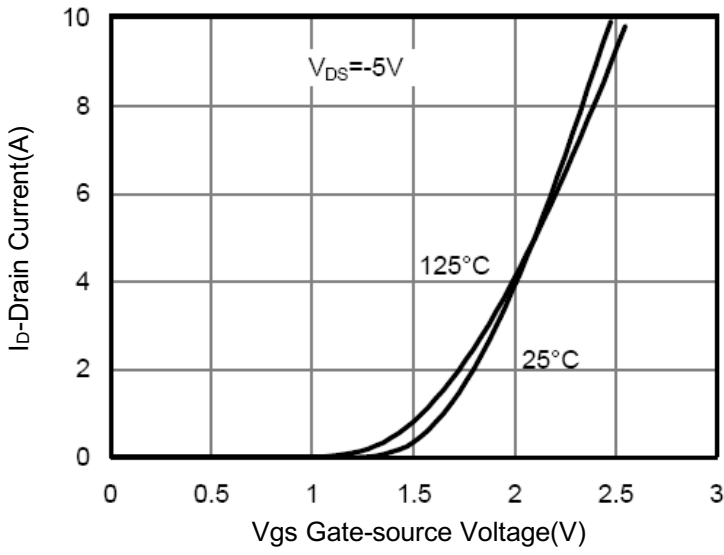

Figure 7 – Transfer Characteristics

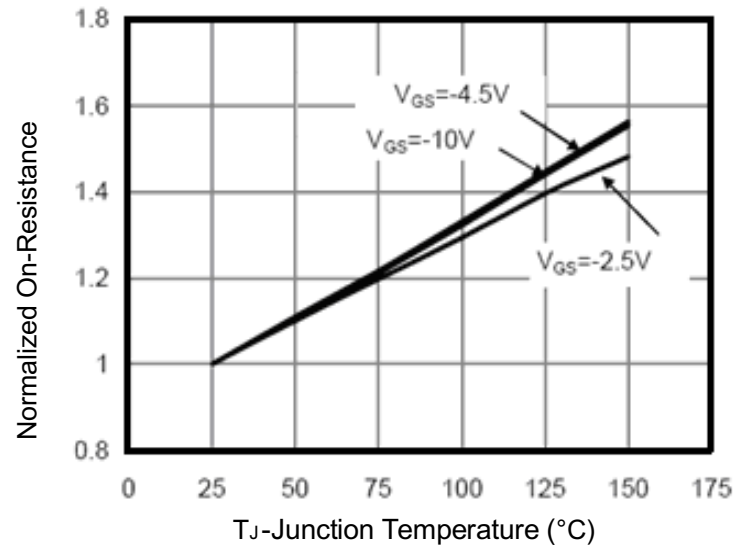

Figure 8 – Drain-Source On-Resistance

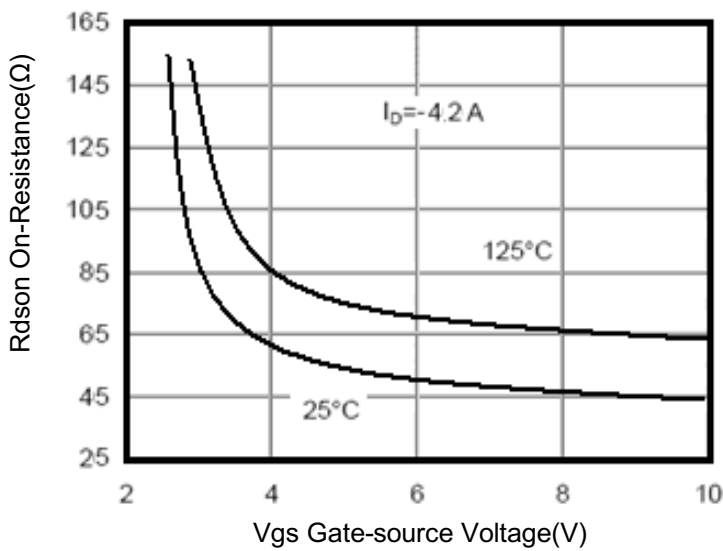

Figure 9 – Rdson vs Vgs

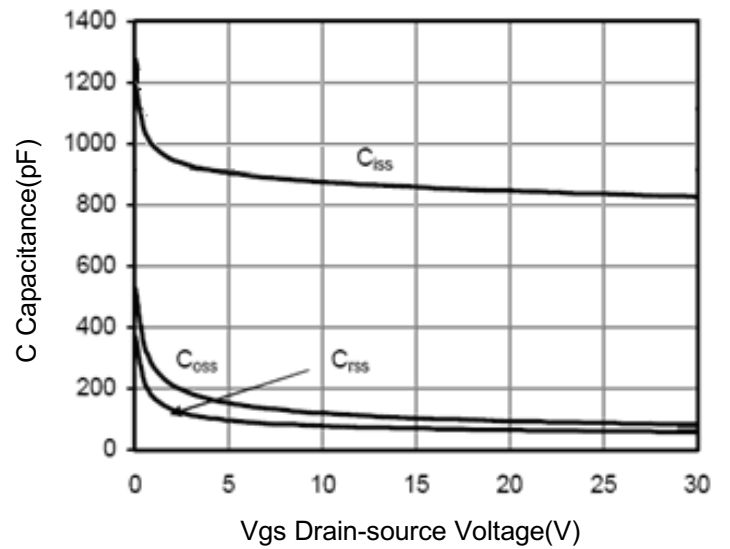

Figure 10 – Capacitance vs Vds

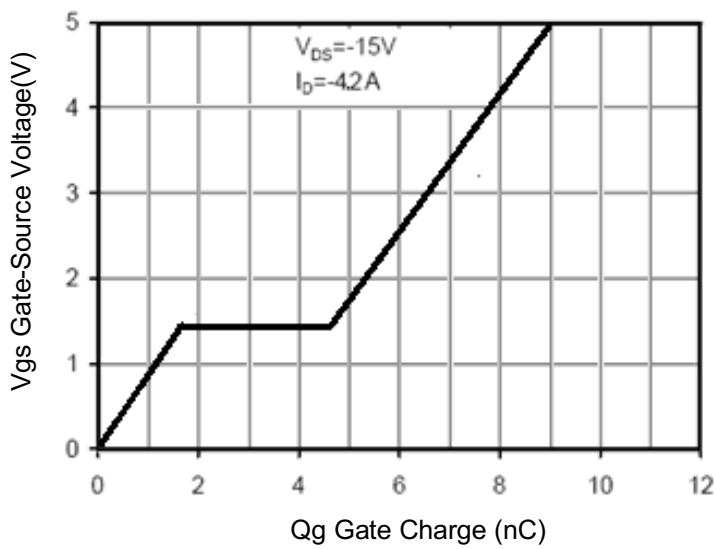

Figure 11 – Gate Charge

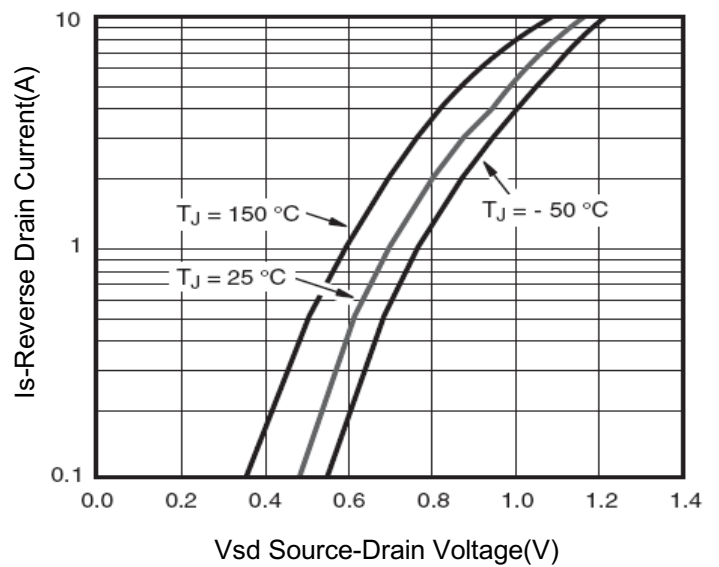

Figure 12 – Source-Drain Diode Forward

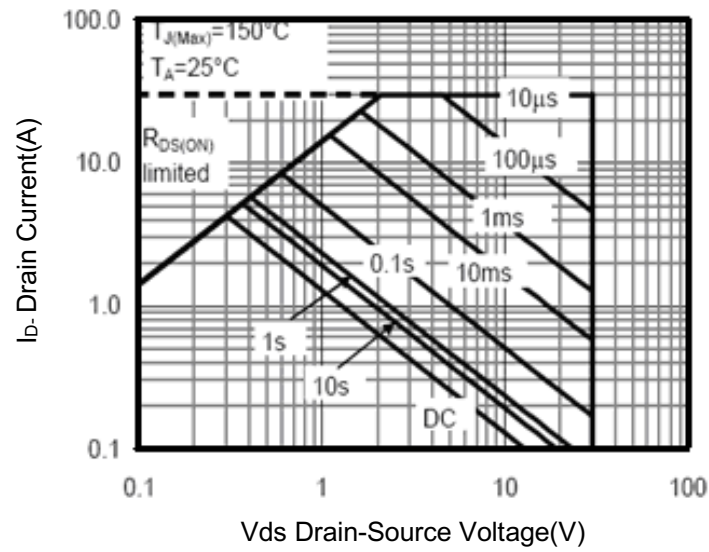

Figure 13 – Safe Operation Area

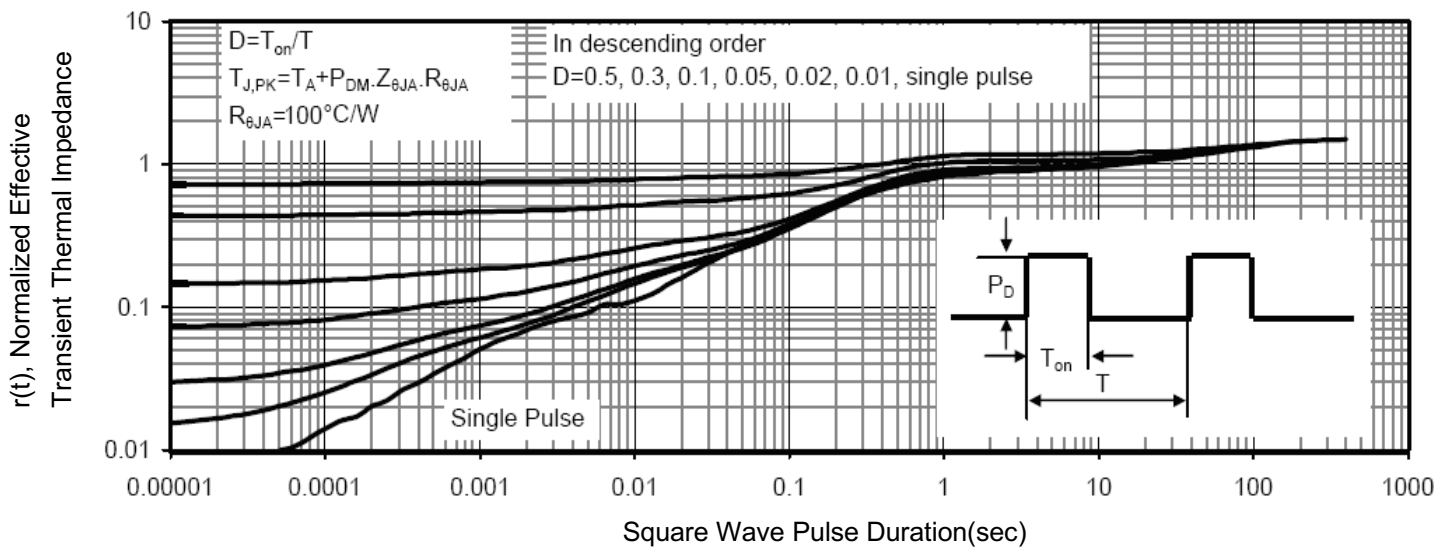
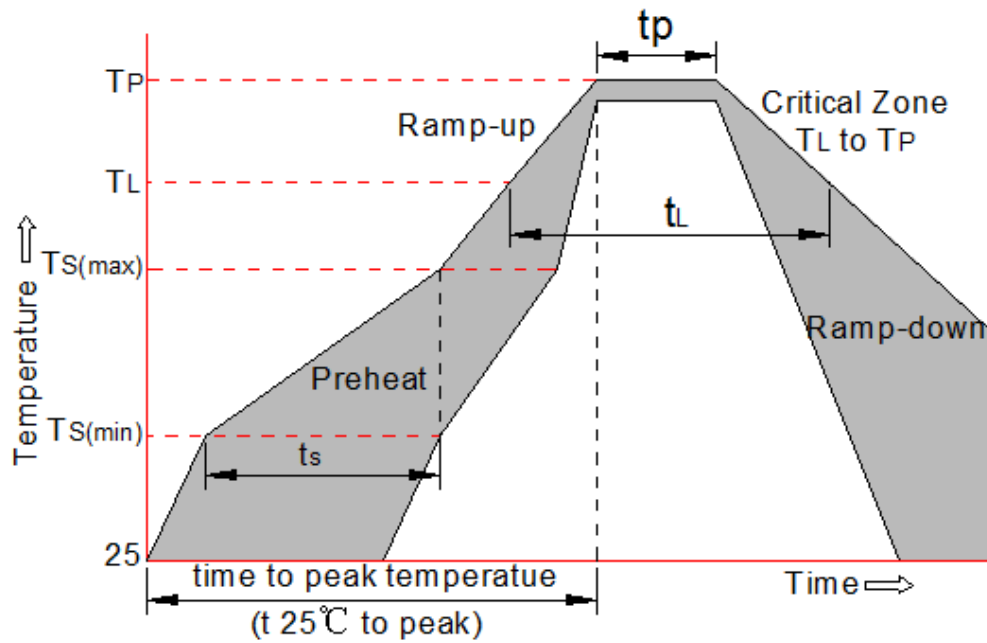

Figure 14 – Normalized Maximum Transient Thermal Impedance

## Soldering Parameters



Reflow Condition		Pb-Free assembly
Pre Heat	-Temperature Min ( $T_{s(min)}$ )	+150°C
	-Temperature Max( $T_{s(max)}$ )	+200°C
	-Time (Min to Max) ( $t_s$ )	60-180 secs.
Average ramp up rate (Liquid us Temp ( $T_L$ ) to peak)		3°C/sec. Max
$T_{s(max)}$ to $T_L$ - Ramp-up Rate		3°C/sec. Max
Reflow	-Temperature( $T_L$ ) (Liquid us)	+217°C
	-Temperature( $t_L$ )	60-150 secs.
Peak Temp ( $T_P$ )		+260(+0/-5)°C
Time within 5°C of actual Peak Temp ( $t_p$ )		30 secs. Max
Ramp-down Rate		6°C/sec. Max
Time 25°C to Peak Temp ( $T_P$ )		8 min. Max
Do not exceed		+260°C

**Package Outline Dimensions (SOT-23)**

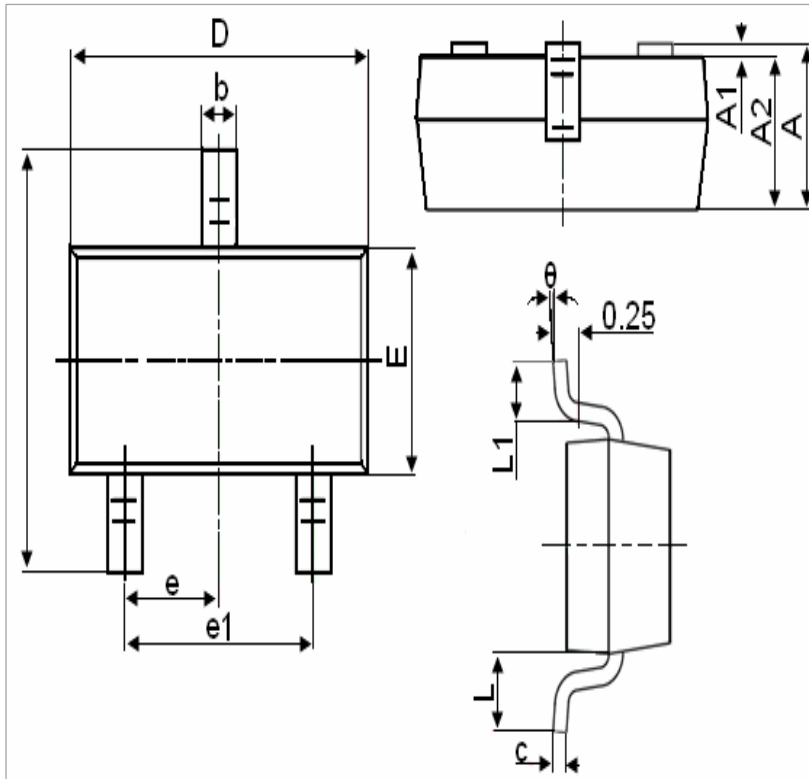

Symbol	Dimensions in Millimeters	
	Min	Max
A	0.900	1.150
A1	0.000	0.100
A2	0.900	1.050
b	0.300	0.500
c	0.080	0.150
D	2.800	3.000
E	1.200	1.400
E1	2.250	2.550
e	0.950 TYP	
e1	1.800	2.000
L	0.55 REF	
L1	0.300	0.500
theta	0°	8°

**Recommend PAD Layout**

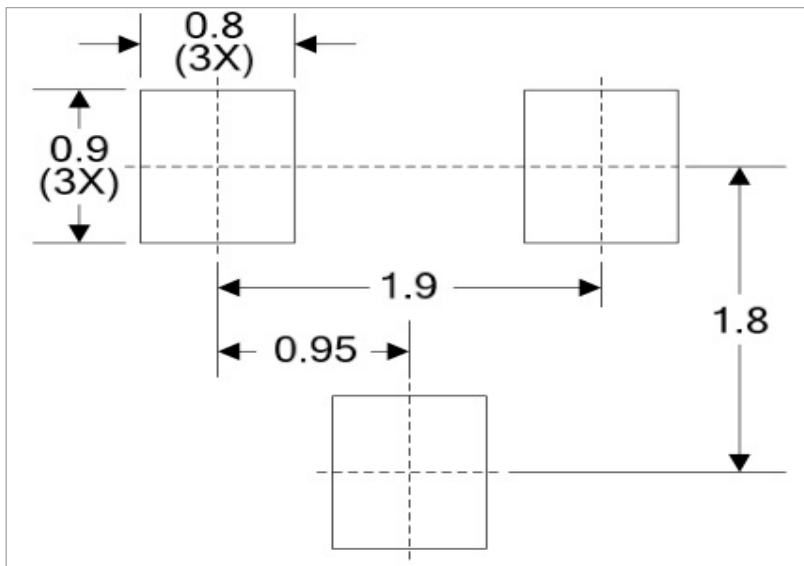

**Notes:**

1. All dimensions are in millimeters.
2. Tolerance  $\pm 0.10\text{mm}$  (4 mil) unless otherwise specified
3. Package body sizes exclude mold flash and gate burrs. Mold flash at the non-lead sides should be less than 5 mils.
4. Dimension L is measured in gauge plane.
5. Controlling dimension is millimeter, converted inch dimensions are not necessarily exact.