

HDMI CONNECTOR



HDMI-201
W8.15xD11.20xH3.20

技术参数 / Technical parameter



PIN数(Number of contacts) : 19PIN	插座类型(Socket type) : HDMI
插座类别(Socket category): 母座/Mother seat	操作方式(Operation mode): 卧式/Horizontal
温度范围(Operating temp): -40°C TO +85°C	操作寿命(Operation life): 5,000 Cycles Min
额定负荷(Rated load): DC 30V 0.5A	焊接方式(Welding mode): 前插后贴/SMT
接触电阻(Contact resistance): $\leq 10m\Omega$	包装方式(Packaging method): 卷带/Tape&Reel(TR)
绝缘电阻(Insulation resistance): $\geq 100M\Omega$	最小包装(Minimum packing): 1,000/PCS

外形尺寸 (UNIT:MM) / Size Chart

www.xunpudianzi.com

更多资料请参考技术选型档!

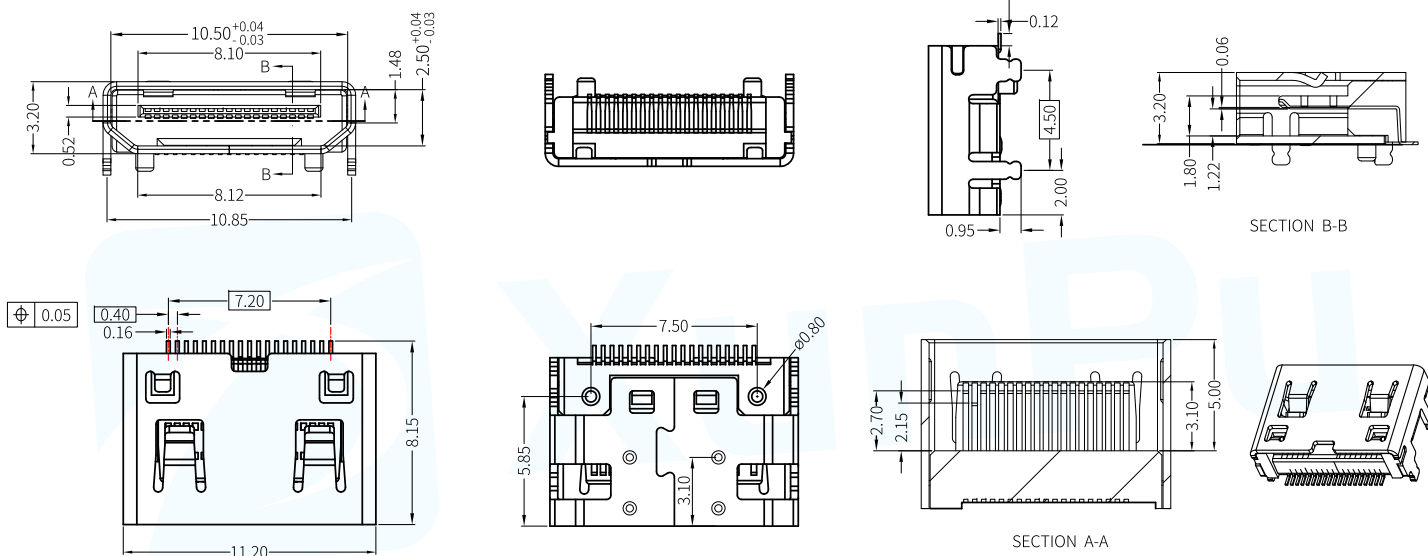

线路板安装 (UNIT:MM) / Mounting Dimensions

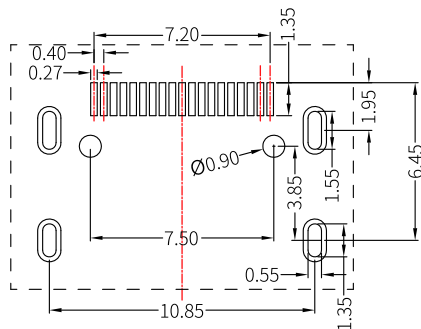

P.C.B LAYOUT(copper-side view)

引脚定义/Pin Definition

PIN	Signal Name	PIN	Signal Name
1	TMDS Data2 Shield	11	TMDS Clock+
2	TMDS Data2+	12	TMDS Clock-
3	TMDS Data2-	13	DDC/CEC Ground
4	TMDS Data1 Shield	14	CEC
5	TMDS Data1+	15	SCL
6	TMDS Data1-	16	SDA
7	TMDS Data0 Shield	17	Utility
8	TMDS Data0+	18	+5V Power
9	TMDS Data0-	19	Hot Plug Detect
10	TMDS Clock Shield		

● 回流焊/Reflow soldering

适用表面贴装型产品/Applicable to surface mount products
温度分布/Temperature distribution



注:

1. 加热方式:以远红外线上下加热方式。
2. 温度测量:用 $\phi 0.1\sim 0.2$ 的 CA(K)或 CC(T)测量位置在焊接连接部(锡/铜箔面)。
3. 固定方式:采用耐热胶带。

● 手焊式/Hand welding

项目/Project	条件/condition
焊接温度 Welding temperature	350°C max.
持续焊接时间 Continuous welding time	3s max.
焊剂斗容量 Flux bucket capacity	60W max.

● 浸焊式/Immersion soldering

项目/Project	条件/condition
助焊剂附着量 Flux adhesion	不附着于零部件贴装面的程度 Not attached to the mounting surface of components
预热温度 Preheating temperature	印刷电路板焊接面的周围温度 100°C max. The temperature around the welding surface of PCB is 100 °C max
预热温度时间 Preheat temperature time	60s max.
焊接温度 welding temperature	260°C max.
焊接浸渍时间 Welding immersion time	5s max.
焊接次数 Welding times	2 times max.