



样品承认书 *Specifications*

客户名称 Customer Name	
品名 Variety	压电式无源蜂鸣器
型号 Ppart No	SFN-1207P7.6
客户型号 The customer Ppart No	
样品日期 Model Date	2018-12-26

客户承认签署

签定结果:		
核准/ <i>Approved:</i>	审核/ <i>Checked:</i>	经办/ <i>Designed:</i>

海旭确认签署

核准/ <i>Approved:</i>	审核/ <i>Checked:</i>	经办/ <i>Designed:</i>
Liou Ni Ding	Huang Mei	Ding Jian Wu

承认后请签回一份! *Thank you very much!*

性能参数 Electrical Characteristics		
型号 Ppart No: SFN-12075-P		
1	额定频率 Resonance Frequency (KHz)	4
2	最大电压 Max Input Voltage (Vp-p)	30
3	电容量 Capacitance at 1000Hz (nF)	11±30%
4	*声压级 Sound Output at 10cm (dB)	≥80 at 4KHz Square Wave 5Vp-p
5	*消耗电流 Current Consumption (mA)	≤5 at 4KHz Square Wave 5Vp-p
6	工作温度 Operating Temperature (°C)	-20~+70
7	储存温度 Storage Temperature (°C)	-30~+80
8	单品重量 Weight (g)	0.7
9	外壳材料 Housing Material	黑色 Black PBT
带*号指标需要在额定电压下测试 *Applying rated voltage		

蜂鸣器焊接方法 Buzzer Soldering process	Soldering Parameter		
	温度 Temp.(°C)	时间 Time(Sec.)	可焊接次数 Times
回流焊 Reflow soldering	245±15	180°C 预热 40~70 秒 245°C 3 秒 above 180°C time 40~70	3
★波峰焊 Wave soldering	255±5	4~6	2~3
手工焊 Manual soldering	350±10	2~5	2~3
接插件			
带★号为众邦电子科技推荐的焊接方法 Remark:★ ZOBA Instance Soldering Process			

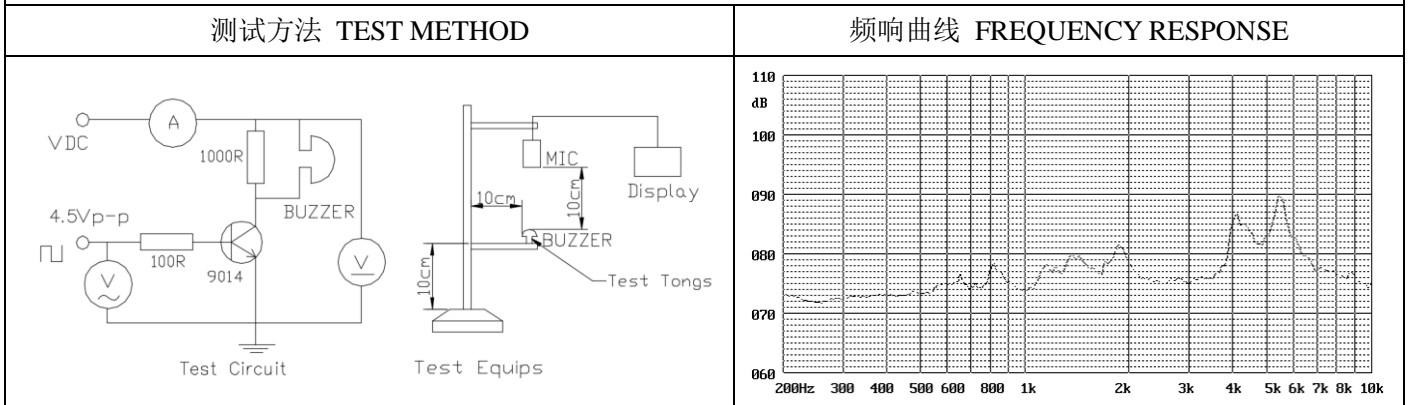
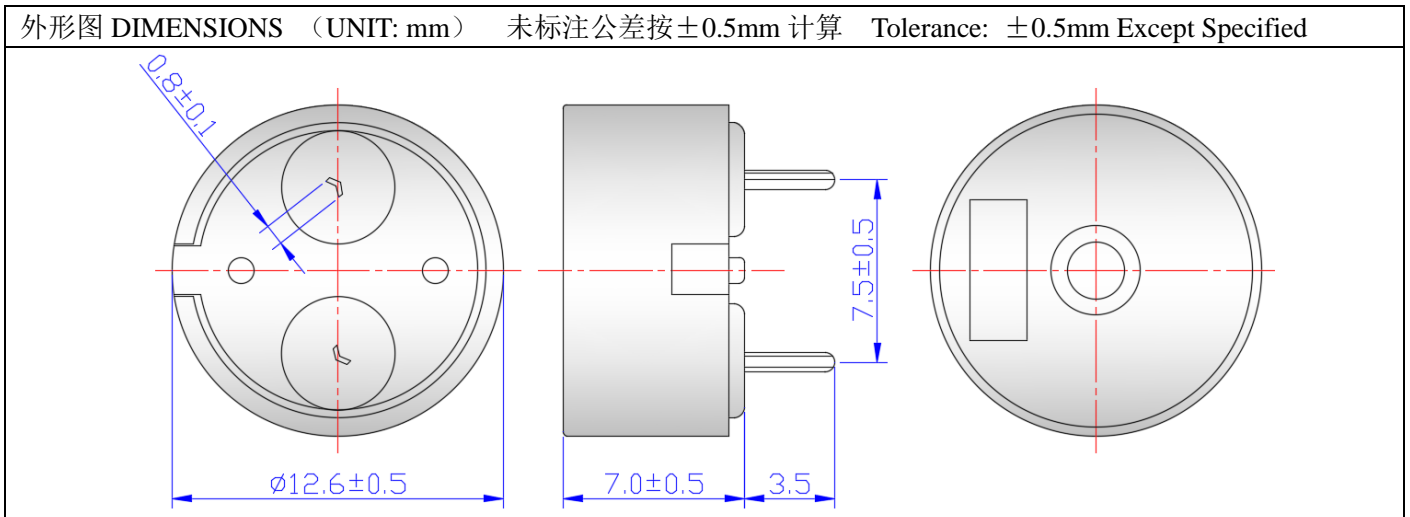

型号 Ppart No: SFN-12075-P		
可靠性测试 RELIABLY TEST		
项目 ITEM	测试条件 TESTING CONDITION	试验后要求 VARIANCE AFTER TEST
高温试验 High Temperature Test	产品置于+80±2℃试验箱中,先工作 2 小时,然后在正常大气压条件下恢复 2 小时后,进行测量。 After being worked in a chamber at +80±2℃ for 2h and then being placed in natural condition for 2h,sounder shall be measured.	试验后,声响器的声级变化值在±10dB 之内,外观无变化(例如:开裂,氧化,损伤,变形等现象) After test,the transducer S.P.L.difference shall be within ±10dB,and the appearance not exist any change to be harmful to normal operation(e.g.crack s,rusts,damages and especially distortion)
低温试验 Low Temperature Test	产品置于-30±2℃试验箱中,先工作 2 小时,再放置 16 小时,然后在正常大气压条件下恢复 2 小时后,进行测量。 First being worked in a chamber at -30±2℃ for 2h and then being planed in a chamber at -30±2℃ for16h,finally being placed in natural condition for2h,sounder shall be measured.	
恒湿试验 Humidity Test	产品置于湿度为 90~95%R.H,温度为 40±2℃试验箱中 48 小时,然后在正常大气压条件下恢复 2 小时后,进行测量。 After being placed in a chamber with 90 to 95%R.H.at+40±2℃ for 48h and then being placed in natural condition for 2h,sounder shall be measured.	
振动试验 Vibration Test	振幅为 0.75mm,频率为 10~30~10Hz,三个不同轴方向各振动 1 小时,试验后测量。 Sounder shall be measured after being applied vibration of amplitude of 0.75mm with 10 to30 to10Hz band of vibration frequency to each of 3 perpendicular directions for 1hour.	
自由落体试验 Freely Falling Test	在 0.8 米高处,将产品三方向自由落体在木板上,试验后测量。 Sounder shall be measured after freely falling the products from 0.8m high to the wooden board with three sides per time.	
碰撞试验 Collision Test	加速度 100±10m/s ² ,脉冲持续时间 16ms,重复频率 1~3 次/min,次数 1000±10 次。试验后测量。 Sounder shall be measured after the test of acceleration 100±10m/s ² ,impulse lasting time 16ms,repeat frequency 1~3/min and time 1000±10.	
可焊性试验 Solderability	引线剥头/针脚浸入松香焊剂 3 秒,然后再浸入+250±5℃的锡锅中 3±0.5 秒,引线剥头表面应覆盖一层光滑明亮的焊料。 Lead terminals are immersed in rosin for 3 seconds and then immersed in solder bath at +250±5℃ for 3±0.5 seconds,terminals should be covered with the clean solder.	
引线/针脚强度试验 Terminal Strength Pulling	引线/针脚应承受 1N 拉力,拉力时间 10 秒,引线无松动和脱落等现象。 The force 10 seconds of 1N is applied to each terminal in axial direction.no looseness and falling off.	