



SMN-327-ACP6
W16.50xD15.90xH1.50

PIN 数(Number of contacts) : 6PIN

耐电压(Withstand voltage) : 500V AC for 1 min

操作方式(Operation mode): 顶针取卡/PIN PUSH

操作寿命(Operation life): 5,000 Cycles Min

温度范围(Operating temp): -40°C TO +80°C

焊接温度(Welding temperature): 260±5° 5s

额定负荷(Rated load): 0.5A PERP IN.

焊接方式(Welding mode): 贴片式/SMT

接触电阻(Contact resistance): 100mΩ max.

包装方式(Packaging method): 卷带/Tape & Reel (TR)

绝缘电阻(Insulation resistance): 1000MΩ min.

最小包装(Minimum packing): 1,000/PCS

外形尺寸 (UNIT:MM) / Size Chart

www.xunpudianzi.com

更多资料请参考技术选型档!

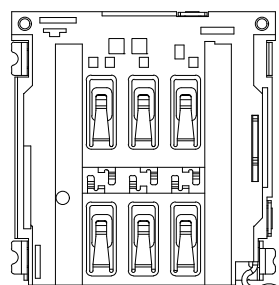
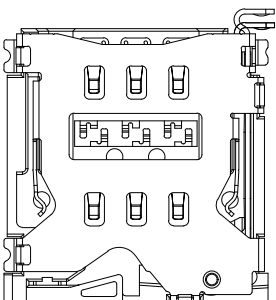
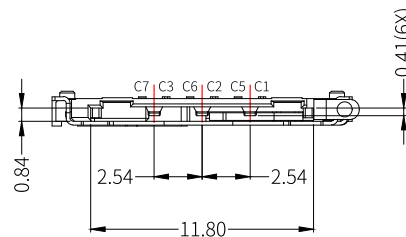
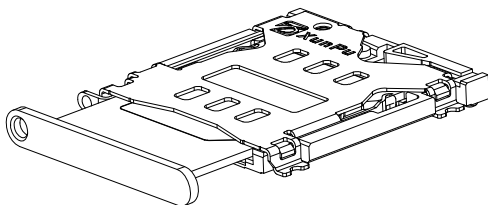
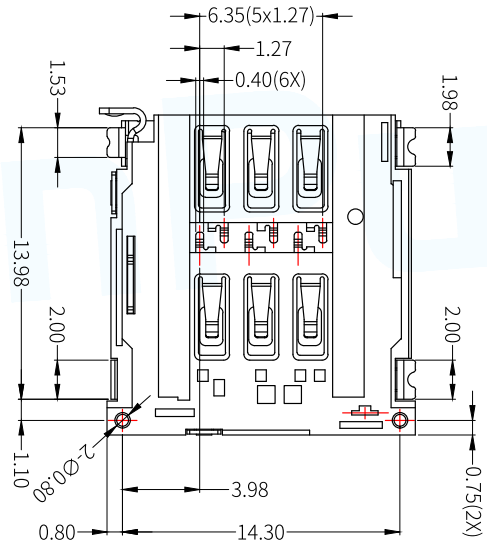
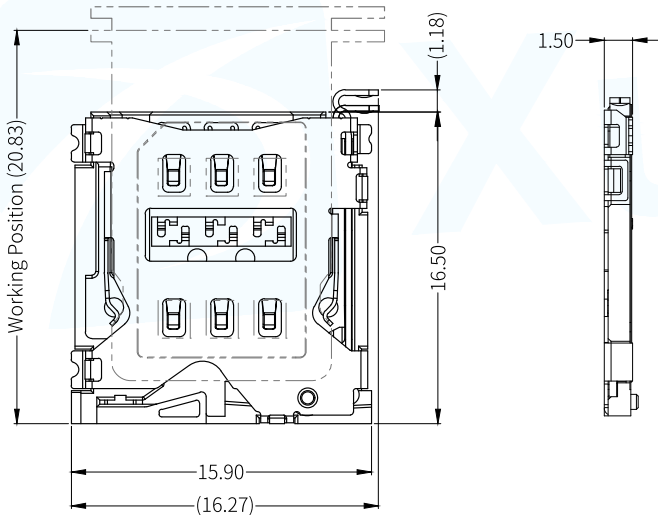
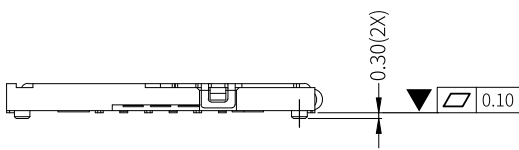

NO.	PART NAME	Q'TY	DESCRIPTION
1	CONTACT	1	BRONZE ALLOY,GOLD PLATING
2	HOUSING	1	LCP,BLACK
3	SHELL	1	SUS,GOLD PLATING
4	LEVER	1	SUS,NO PLATING
5	HINGE	1	SUS,NO PLATING

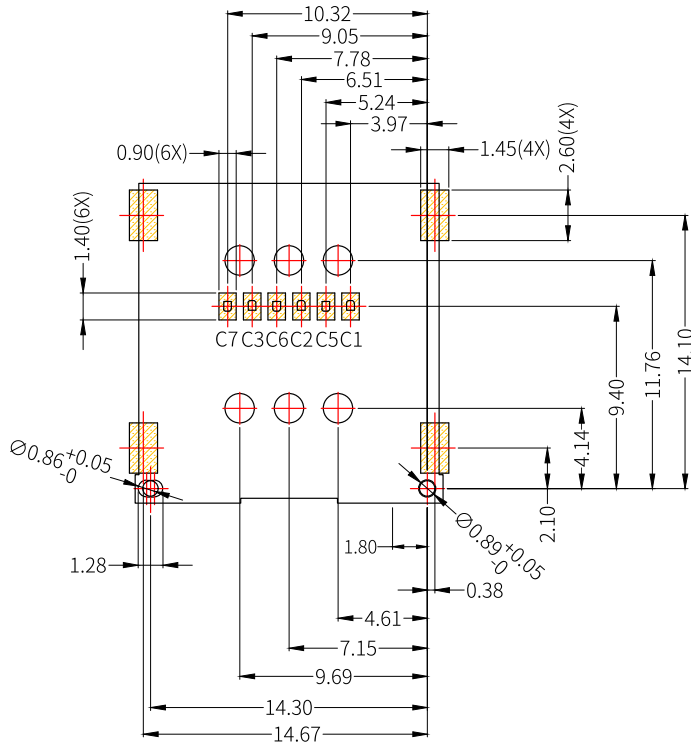

PCB焊盘区(PAD AREA)
 禁区(KEEP OUT AREA)

RECOMMENDED PCB LAYOUT
GENERAL TOLERANCE ± 0.05

● NANO SIM

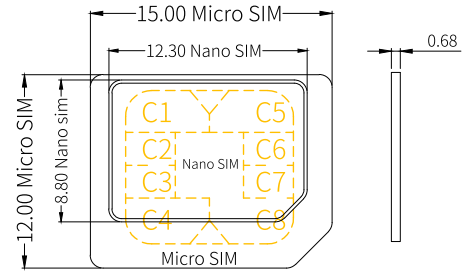

● 引脚定义/Pin Definition

SIM PIN ASSIGNMENT			
PIN#	NAME	TYPE	DESCRIPTION
C1	供电电压	1	VCC
C2	重置	1	RST
C3	时钟	1	CLK
C5	接地	1	GND
C6	程序电压	1	VPP
C7	输入输出	1	I/O

焊接条件 / Welding conditions

● 回流焊/Reflow soldering

适用表面贴装型产品/Applicable to surface mount products
温度分布/Temperature distribution

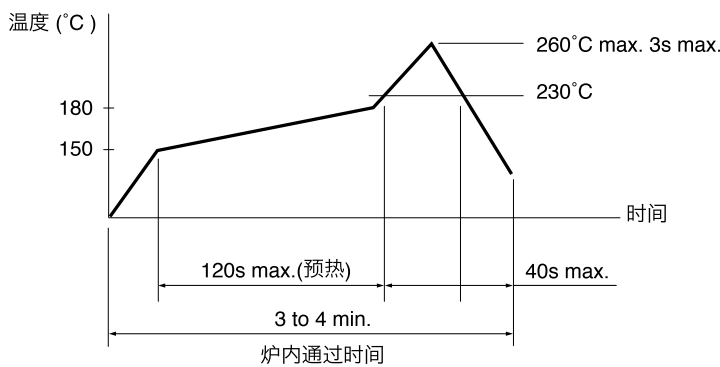

注:

1. 加热方式:以远红外线上下加热方式。
2. 温度测量:用 $\Phi 0.1\sim 0.2$ 的CA(K)或CC(T)测量位置在焊接连接部(锡/铜箔面)。
3. 固定方式:采用耐热胶带。

● 手焊式/Hand welding

项目/Project	条件/condition
焊接温度 Welding temperature	350°C max.
持续焊接时间 Continuous welding time	3s max.
焊剂斗容量 Flux bucket capacity	60W max.

● 浸焊式/Immersion soldering

项目/Project	条件/condition
助焊剂附着量 Flux adhesion	不附着于零部件贴装面的程度 Not attached to the mounting surface of components
预热温度 Preheating temperature	印刷电路板焊接面的周围温度 100°C max. The temperature around the welding surface of PCB is 100 °C max
预热温度时间 Preheat temperature time	60s max.
焊接温度 welding temperature	260°C max.
焊接浸渍时间 Welding immersion time	5s max.
焊接次数 Welding times	2 times max.