

承認書

Specification For Approval

Customer: (客戶)

Description: (產品描述)

LED(SMD)

Part number: (產品型號)

TJ-S2835W50KDC-A3

Date: (日期)

Approved By: (客戶承認)

Prepared By: (我司承認)

Approval	Check	Design	Sales
核准	審核	製作	業務

Customer Service Hotline: **400-676-8616**

TEL: 0769-8662 5999 0769-8200 2226

E-MAIL : dg@togialed.com

FAX: 0769-8200 2227

WEB: www.togialed.com

● **Features:**

1. Emitted Color: White.
2. Lens Appearance: Yellow Diffuse.
3. 35x28x08 mm mm standard package.
4. Suitable for all SMT assembly methods.
5. Compatible with infrared and vapor phase reflow solder process.
6. Compatible with automatic placement equipment.
7. This product doesn't contain restriction Substance, comply ROHS standard.

● **Applications:**

1. Automotive: Dashboards, stop lamps, turn signals.
2. Backlighting: LCDs, Key pads advertising
3. Status indicators: Consumer & industrial electronics.
4. General use.



● **Package Dimensions:**

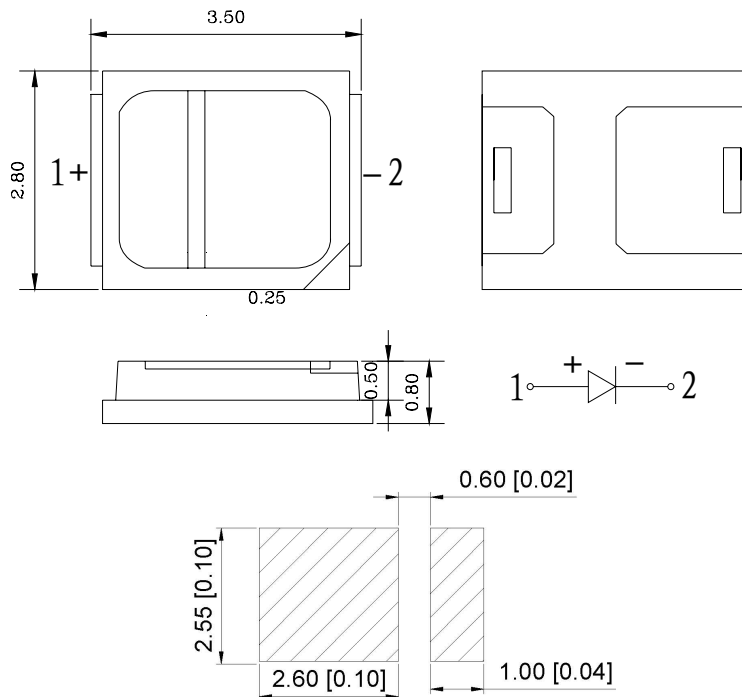

Notes:

1. All dimensions are in millimeters.
2. Tolerance is ± 0.2 unless otherwise noted.
3. Specifications are subject to change without notice.

● **Absolute Maximum Ratings (Ta=25°C)**

Item	Symbol	Value	Unit
Power Dissipation/DICE	PD	320	mW
DC Forward Current/DICE	IF	60	mA
Pulse Forward Current	IFP	150	mA
Reverse Voltage	VR	5	V
Operating Temperature	Topr	-30 ~ +80■	°C
Storage Temperature	Tstg	-40 ~ +100	°C
Soldering Temperature	Tsol	260for5sec△	°C

※Duty 1/10 , Pulse Width 0.1ms.

△Soldering time max 10sec

Parameter	Symbol	Value			Unit	Test condition
		Min.	Typ.	Max.		
Forward Voltage	Vf	-	2.7	-	V	If=60mA
Reverse Current	Ir	-	-	10	μA	Vr=5V
Viewing angle	2θ1/2	-	120	-	Deg	If=60mA
Chromaticity coordinate	X	-	-	-	-	If=60mA
	Y	-	-	-	-	
Color Temperature	CCT	5300	-	5700	K	If=60mA
Luminous intensity	Iv	24	-	28	Lm	If=60mA
Color Rendering Index	CRI	-	80	-	-	If=60mA

● Color Bin Limits (At 60 mA)

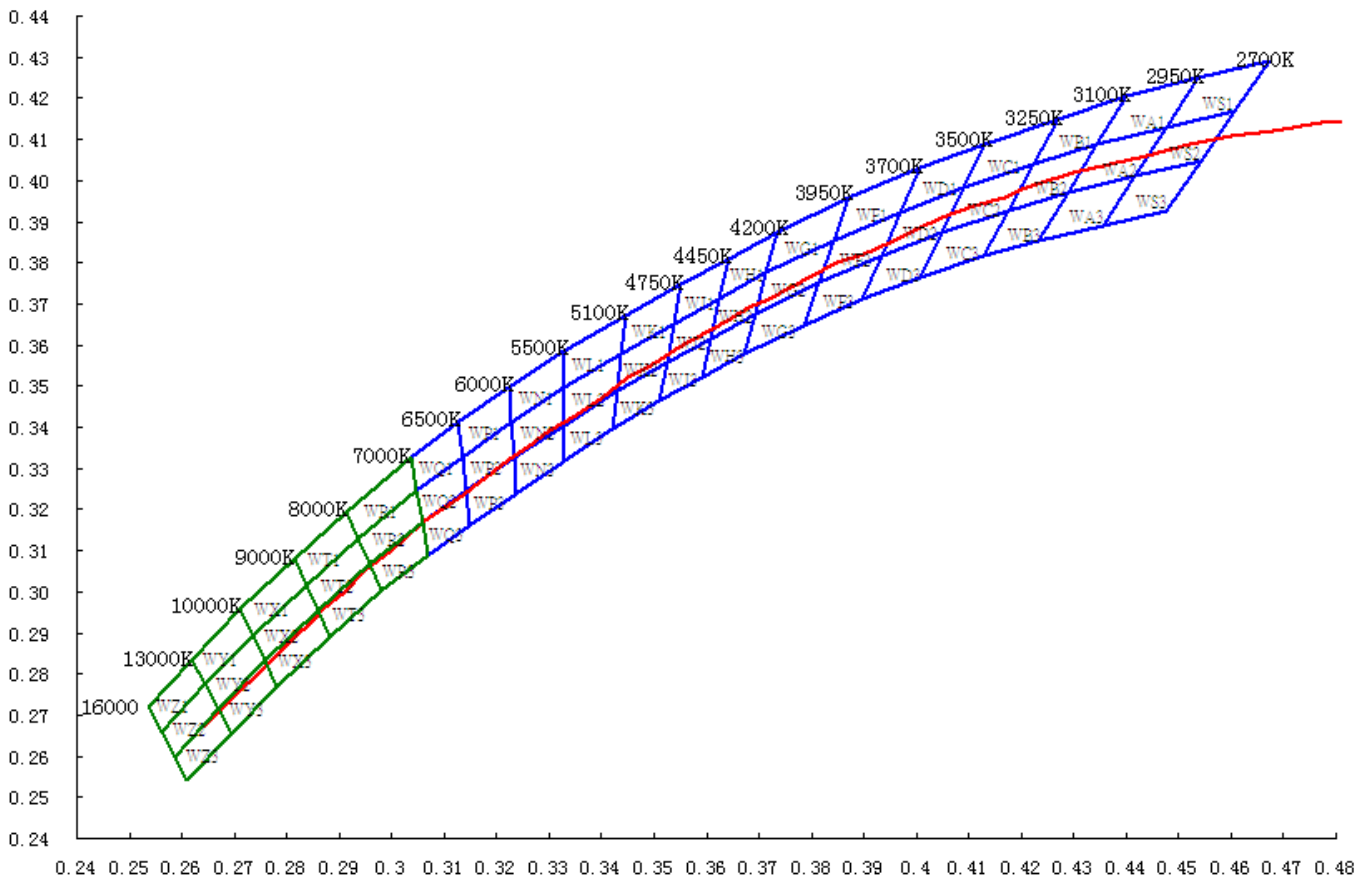
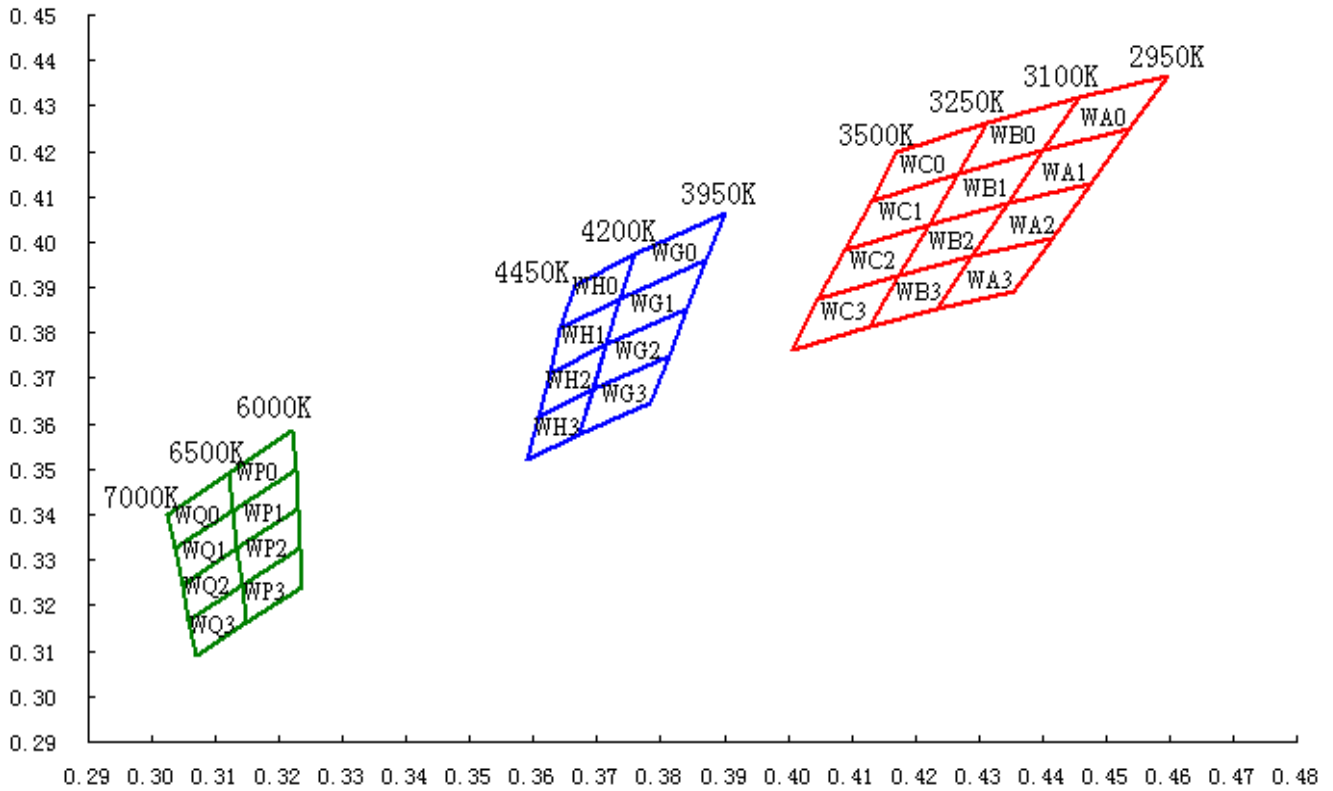

● **Color Bin Limits (At 60mA)**

Warm White

Bin Code	X	Y	Bin Code	X	Y	Bin Code	X	Y
WA0	0.4598	0.4368	WB0	0.4458	0.4321	WC0	0.4313	0.4261
	0.4538	0.4249		0.4400	0.4204		0.4269	0.4150
	0.4400	0.4204		0.4269	0.4150		0.4131	0.4090
	0.4458	0.4321		0.4313	0.4261		0.4172	0.4199
	0.4598	0.4368		0.4458	0.4321		0.4313	0.4261
WA1	0.4538	0.4249	WB1	0.4400	0.4204	WC1	0.4269	0.4150
	0.4477	0.4130		0.4345	0.4087		0.4222	0.4039
	0.4345	0.4087		0.4222	0.4039		0.4090	0.3981
	0.4400	0.4204		0.4269	0.4150		0.4131	0.4090
	0.4538	0.4249		0.4400	0.4204		0.4269	0.4150
WA2	0.4477	0.4130	WB2	0.4345	0.4087	WC2	0.4222	0.4039
	0.4416	0.4010		0.4289	0.3971		0.4175	0.3927
	0.4289	0.3971		0.4175	0.3927		0.4048	0.3873
	0.4345	0.4087		0.4222	0.4039		0.4090	0.3981
	0.4477	0.4130		0.4345	0.4087		0.4222	0.4039
WA3	0.4416	0.4010	WB3	0.4289	0.3971	WC3	0.4175	0.3927
	0.4355	0.3891		0.4234	0.3854		0.4128	0.3816
	0.4234	0.3854		0.4128	0.3816		0.4007	0.3764
	0.4289	0.3971		0.4175	0.3927		0.4048	0.3873
	0.4416	0.4010		0.4289	0.3971		0.4175	0.3927

Natural White

Bin Code	X	Y	Bin Code	X	Y
WG0	0.3902	0.4063	WH0	0.3758	0.3973
	0.3871	0.3959		0.3736	0.3874
	0.3736	0.3874		0.3642	0.3809
	0.3758	0.3973		0.3664	0.3907
	0.3902	0.4063		0.3758	0.3973
WG1	0.3871	0.3959	WH1	0.3736	0.3874
	0.3842	0.3855		0.3714	0.3775
	0.3714	0.3775		0.3625	0.3712
	0.3736	0.3874		0.3642	0.3809
	0.3871	0.3959		0.3736	0.3874
WG2	0.3842	0.3855	WH2	0.3714	0.3775
	0.3813	0.3751		0.3692	0.3677
	0.3692	0.3677		0.3608	0.3616
	0.3714	0.3775		0.3625	0.3712
	0.3842	0.3855		0.3714	0.3775
WG3	0.3813	0.3751	WH3	0.3692	0.3669
	0.3784	0.3647		0.3670	0.3578
	0.3670	0.3578		0.3591	0.3522
	0.3692	0.3677		0.3608	0.3616
	0.3813	0.3751		0.3692	0.3677

Cool White

Bin Code	X	Y	Bin Code	X	Y
WP0	0.3222	0.3587	WQ0	0.3121	0.3491
	0.3226	0.3500		0.3127	0.3411
	0.3127	0.3411		0.3036	0.3326
	0.3121	0.3491		0.3025	0.3401
	0.3222	0.3587		0.3121	0.3491
WP1	0.3226	0.3500	WQ1	0.3127	0.3411
	0.3229	0.3413		0.3134	0.3328
	0.3134	0.3328		0.3047	0.3247
	0.3127	0.3411		0.3036	0.3326
	0.3226	0.3500		0.3127	0.3411
WP2	0.3229	0.3413	WQ2	0.3134	0.3328
	0.3233	0.3327		0.3142	0.3246
	0.3142	0.3246		0.3058	0.3168
	0.3134	0.3328		0.3047	0.3247
	0.3229	0.3413		0.3134	0.3328
WP3	0.3233	0.3327	WQ3	0.3142	0.3246
	0.3236	0.3240		0.3149	0.3163
	0.3149	0.3163		0.3069	0.3089
	0.3142	0.3246		0.3058	0.3168
	0.3233	0.3327		0.3142	0.3246

● **Typical Electro-Optical Characteristics Curves**

Fig.1 RELATIVE INTENSITY VS. WAVELENGTH

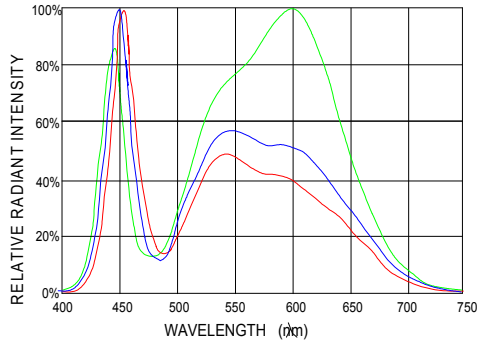

Fig.2 FORWARD CURRENT VS. AMBIENT TEMPERATURE

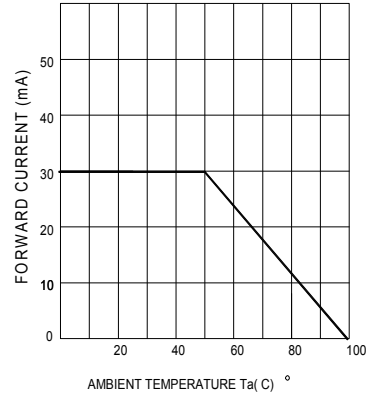

Fig.3 FORWARD CURRENT VS. FORWARD VOLTAGE

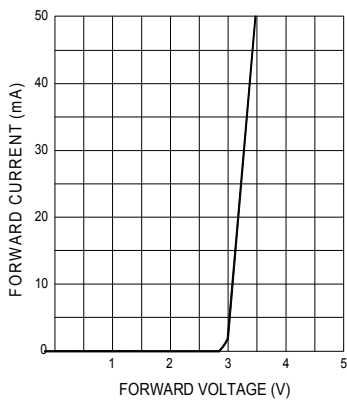

Fig.4 RELATIVE LUMINOUS INTENSITY VS. AMBIENT TEMPERATURE

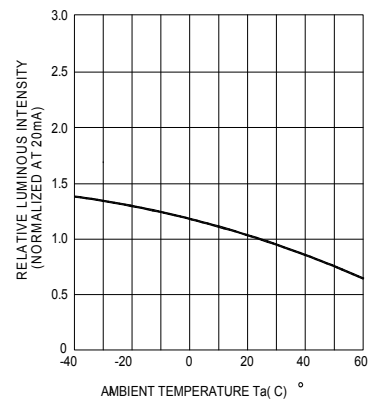

Fig.5 RELATIVE LUMINOUS INTENSITY VS. FORWARD CURRENT

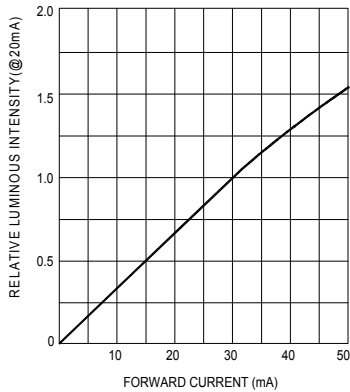
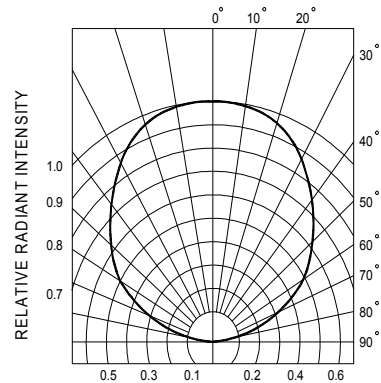

Fig.6 RADIATION DIAGRAM



● **Test items and results of reliability**

Type	Test Item	Test Conditions	Note	Number of Damaged
Operation Sequence	Life Test	T _a =25℃ I _F =60mA	1000 hrs	0/22
	High Humidity Heat Life Test	85℃ RH=85% I _F =60mA	500 hrs	0/22
	Low Temperature Life Test	T _a =-20℃ I _F =60mA	1000 hrs	0/22
Environmental Sequence	Temperature Cycle	-45℃ 30min ↑↓20 min 105℃ 30min	100 cycle	0/22
	Thermal Shock	-10℃ 15min ↑↓5sec 100℃ 15min	100 cycle	0/22
	High Humidity Heat Cycle	30℃ ↔ 65℃ 90%RH 24hrs/1cycle	10 cycle	0/22
	High Temperature Storage	T _a =100℃	1000 hrs	0/22
	Humidity Heat Storage	T _a =85℃ RH=85%	1000 hrs	0/22
	Low Temperature Storage	T _a =-40℃	1000 hrs	0/22

● **Judgment criteria of failure for the reliability**

Measuring items	Symbol	Measuring conditions	Judgment criteria for failure
Forward voltage	V _F (V)	I _F =60mA	Over U ¹ x1.2
Reverse current	I _R (uA)	V _R =5V	Over U ¹ x2
Luminous intensity	I _v (mcd)	I _F =60mA	Below S ¹ X0.5

Note: .1. U means the upper limit of specified characteristics. S means initial value.

2. After each test, remove test pieces, wait for 2 hours and test pieces have returned to ambient temperature, then take next measurement.

● **Soldering :**

1. Manual Soldering

The temperature of the iron tip should not be higher than 350°C and Soldering time to be within 3 seconds per solder-pad.

2. Reflow Soldering

Preheating : 140°C~160°C±5°C, within 2 minutes.

Operation heating : 260°C (Max.) within 10 seconds. (Max)

Gradual Cooling (Avoid quenching).

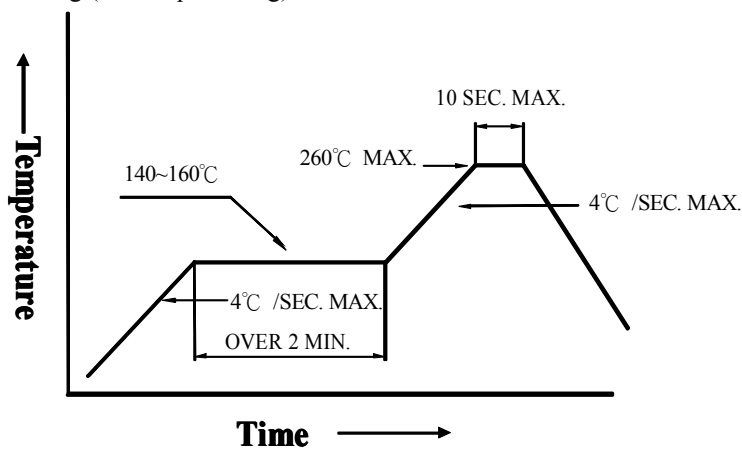

3. DIP soldering (Wave Soldering) :

Preheating : 120°C~150°C, within 120~180 sec.

Operation heating : 245°C±5°C within 5 sec. 260°C (Max)

Gradual Cooling (Avoid quenching).

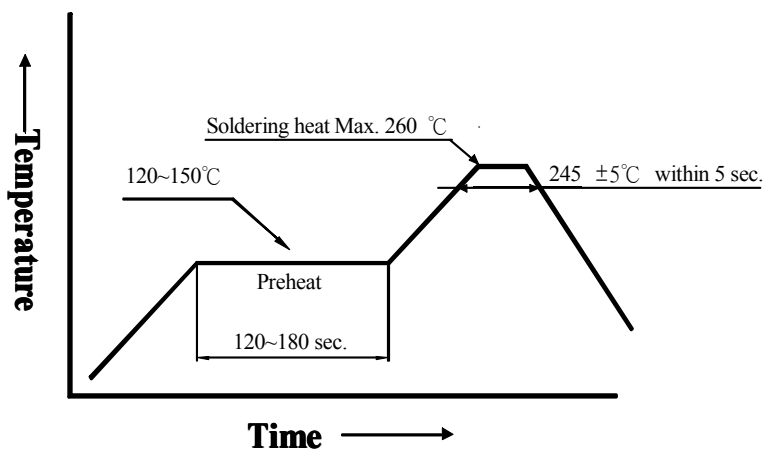

● **Handling :**

Care must be taken not to damage LED's epoxy resin while exposing to high temperature or contact LED's epoxy resin with hard or sharp objects, such as metal hook, tweezer or sand blasting.

● **Notes for designing:**

Current limiting resistor must be used in the circuit to drive TOGIA LEDs within the rated figures and not to overload TOGIA LEDs with instantaneous voltage at the turning ON and OFF cycles.

When using pulse driving, the average current must be within the rated figures. And the circuit should be designed to avoid reverse voltage when turning off the TOGIA LEDs.

● **Storage:**

In order to avoid the absorption of moisture, it is recommended to solder TOGIA LEDs as soon as possible after unpacking the sealed envelope.

If the envelope is still packed, to store it in the environment as following:

- (1) Temperature : 5°C-30°C(41°F) Humidity : RH 60% Max.
- (2) After this bag is opened, devices that will be applied to infrared reflow, vapor-phase reflow, or equivalent soldering process must be:
 - a. Completed within 168 hours.
 - b. Stored at less than 30% RH.
- (3) Devices require baking before mounting, if:
 - (2) a or (2) b is not met.
- (4) If baking is required, devices must be baked under below conditions:
48 hours at 60°C±3°C.

● **Package and Label of Products:**

Package: Products are packed in one bag of 4000 pcs (one taping reel) and a label is attached to each bag.

Packaging

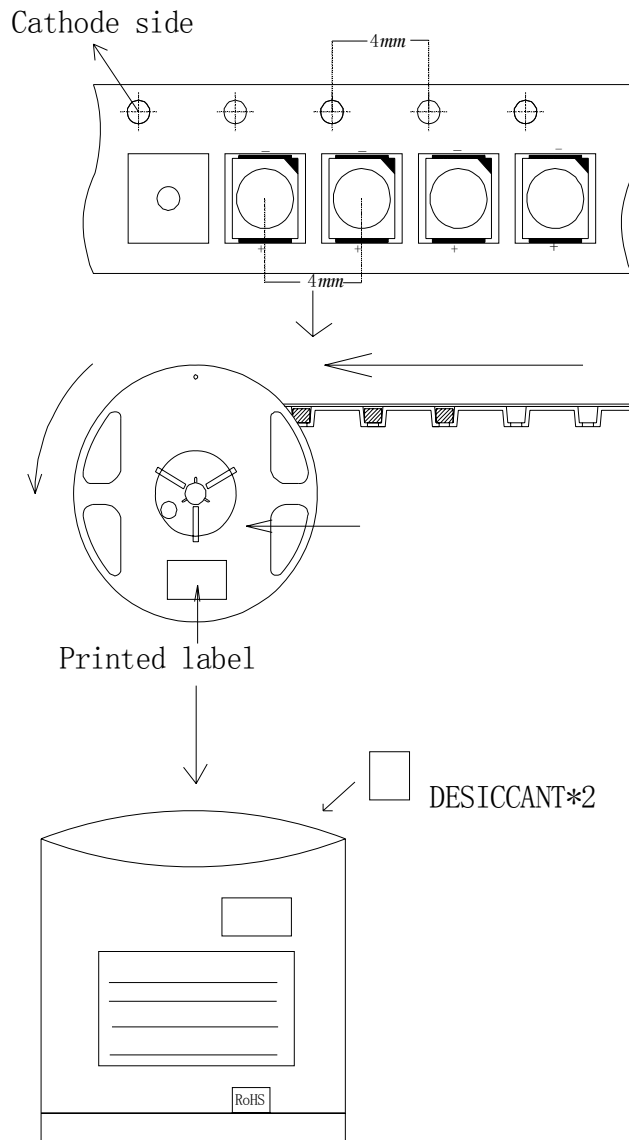

NOTES :

1. Empty component pockets are sealed with top cover tape;
2. The maximum number of missing lamps is two;
3. The cathode is oriented towards the tape sprocket hole in accordance with ANSI/EIA RS-481 specifications.
4. 4,000 pcs / Reel.