

規格承認書

PECIFICATION FOR APPROVAL

客戶
CUSTOMER : _____
項目
ITEM : 驻极体电容咪头 (ECM)
型號
TYPE : GMI6022-2C56DB
描述
DESCRIPTION : $\phi 6.0 \times H2.2$ mm 焊点 2.0V 1033 -56 dB $\leq 2.2K \Omega$ S/N: ≥ 58 dBA
客戶料號
CUSTOMER NO. : _____
規格書號
SPECIFICATION NO.: _____
版本
EDITION NO. : V1.1
日期
DATE : 2020-1-9

客戶承認

CUSTOMER CONFIRM AND SIGN

| 檢查 TESTED BY | 審核 CHECKED BY | 承認 APPROVED BY |
|-----------------|------------------|-------------------|
| | | |

東莞市贏海電子有限公司

DONGUAN INGHAI ELECTRONICS CO.,LTD

| 製作 ISSUED BY | 審查 CHECKED BY | 確認 APPROVED BY |
|-----------------|------------------|-------------------|
| 周明 | 刘承成 | |

地址：广东省东莞市虎门镇怀德社区雅瑶工业区旧村二巷一号 2~4F

電話 / TEL: 0769-83060958 傳真 / FAX: 0769-81608993

網址: HTTP://WWW.INGHAI.COM

A. SCOPE

This specification applies electret condenser microphone, GMI6022-2C56DB

B. SPECIFICATION

■ Test condition: $R_L=2.2K\Omega$ $V_S=2.0V$ $TEMP=20^{\circ}C\pm 2^{\circ}C$ Related humidity= $65\pm 5\%$

| No. | Item | Symbol | Unit | Specification | Condition |
|-----|----------------------------|----------------------|------------|-------------------|----------------------------------|
| 1 | Directivity | | | Omnidirectional | |
| 2 | Sensitivity | S | dB | -56±3 | f=1KHz, 1Pa 0dB=1V/Pa |
| 3 | Standard operating voltage | Vs | V | 2.0 | |
| 4 | Output impedance | Zout | K Ω | ≤2.2 | f=1KHz, 1Pa |
| 5 | Frequency | | Hz | 100-10,000 | |
| 6 | Max operating voltage | | V . | 10 | |
| 7 | Sensitivity reduction | Δ S-Vs | dB | -3 | f=1KHz, 1Pa Vs=1.5VDC to 3VDC |
| 8 | Max. current consumption | Idss | mA | ≤0.5 | |
| 9 | Signal to noise ration | S/N | dBA | ≥58 | f=1KHz, P in=1Pa |
| 10 | Max input sound level | SPL | dB | 110 | |
| 11 | Operation temp. | | °C | -30 ~+70 | |
| 12 | Storage temp. | | °C | -40 ~+85 | |
| 13 | Dimension | | mm | ϕ 6.0 x H2.2 | See appearance drawing |
| 14 | Terminal | | | Terminal | See appearance drawing |

C. TYPICAL FREQUENCY RESPONSE CURVE

全指向性

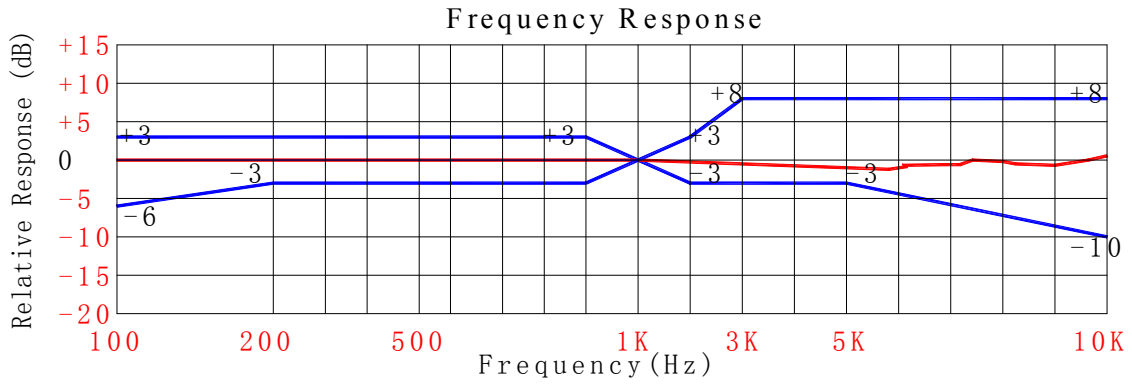

D. APPEARANCE DRAWING

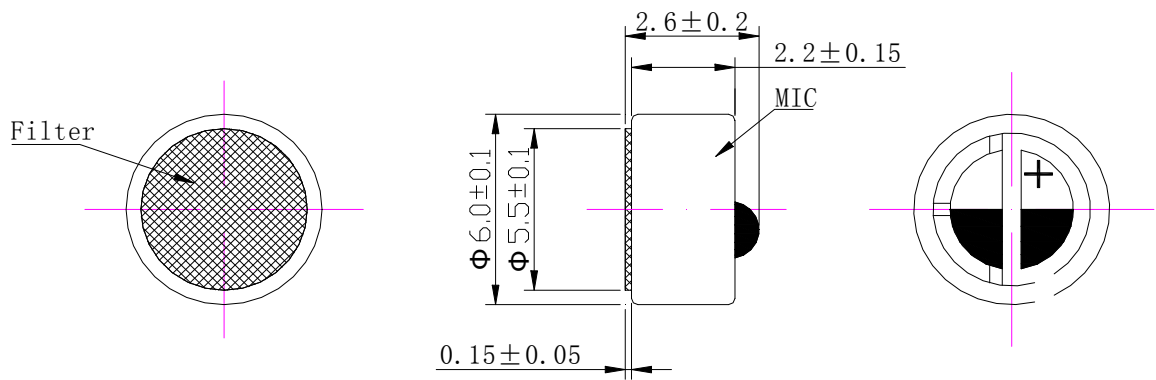

E. MEASUREMENT CIRCUIT

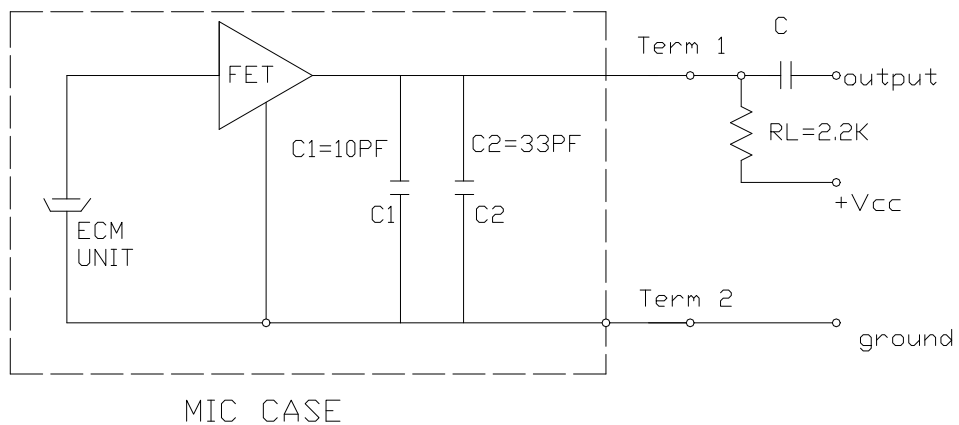

F. Explode Drawing

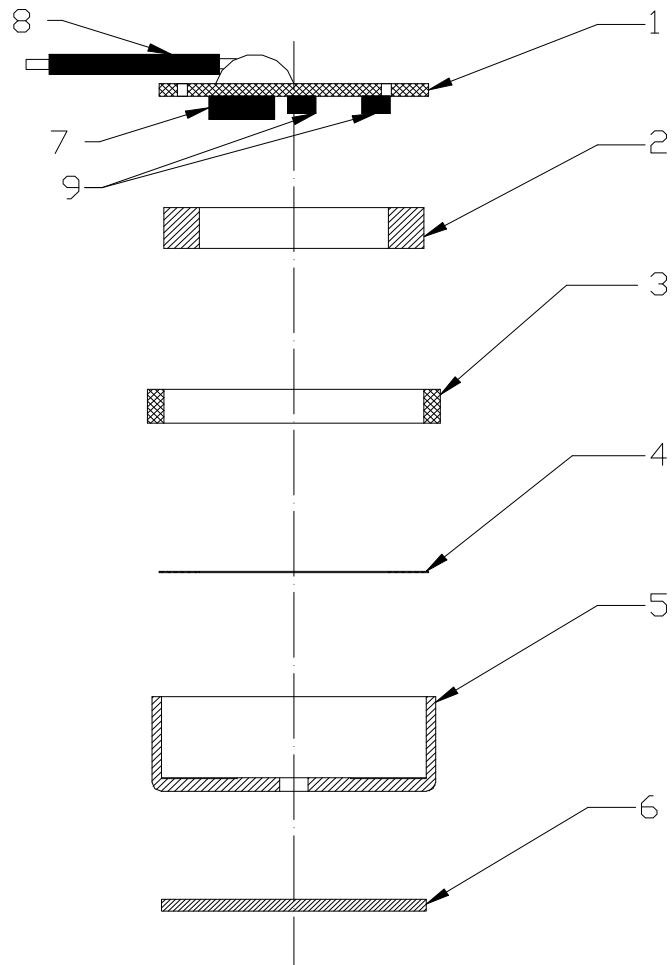

| NO. | PARTS |
|-----|----------------------|
| 1 | PCB |
| 2 | Film(FEP) |
| 3 | Holder |
| 4 | Spacer |
| 5 | Outer most shell(Al) |
| 6 | Protection fleece |
| 7 | FET |
| 8 | Electronic line |
| 9 | Capacitance |

| G. 可靠性试验 Reliability Test | |
|---|---|
| 经过以下所有试验在 20℃ 的条件下放置 3 小时后,麦克风的灵敏度与试验前比较变化在 3dB 以内 After any following tests, the sensitivity of the microphone to be within $\pm 3\text{dB}$ of initial sensitivity after 3hours of conditioning at 20℃ | |
| 5-1 振动试验 Vibration | 周波数 1/Frequency1:10Hz~55Hz 振幅/Amplitude:1.52mm 变化/Change of Frequency:1 octave/min 3 方向,各 2 小时/hours in each of 3 axes |
| 5-2 高温试验 Dry Heat | +80 \pm 5℃ for 96 hours |
| 5-3 低温试验 Dry Cold | -40 \pm 5℃ for 96 hours |
| 5-4 高温高湿试验 Damp Heat | 90%~95%RH, +60 \pm 5℃ for 96 hours |
| 5-5 温度循环试验 Temperature cycles | -20℃ \longleftrightarrow 25℃ \longleftrightarrow 70℃ (2h) (1h) (2h) (1h) (2h) \times 10 cycles |
| 5-6 跌落试验 Packing drop test | Height:1m 顺序:三个面各跌 10 次 Procedure:10 times from each of 3 axes |
| 5-7 温度冲击试验 Temperature impact test | -20℃ \longleftrightarrow 70℃ 30min 30s 30min \times 10 cycles |
| 5-8 静电冲击试验 Electrostatic shock test | 6000V(contact), 15000V(air) \times 10 axes |
| 备注 Note | |
| 6-1 工作温度范围 Operation Temperature | -30℃~70℃ |
| 6-2 储存温度范围 Storage Temperature | -40℃~85℃ |
| H. 焊接条件 | |
| Soldering Condition | |
| 7-1 焊接使用 90W 的烙铁。 The soldering copper of a type of 90W shall be applied | |
| 焊接条件 Soldering Condition. | |
| 7-2 电烙铁表面温度 320 \pm 10℃ The temperature of the working surface of the soldering copper shall be 320 \pm 10℃ | |
| 7-3 焊接时把麦克风嵌入散热能力强的金属块内。 | |

ECM shall be soldered fixed on the metal block(heat sink)which has the higher radiation effects said heat sink

Shall contact with of ECM.

7-4 焊接时间控制在 2~3 秒内。

time for each terminal shall be 2~3 sec.

7-5 焊接后不能出现针孔。

The pinhole after soldering shall be avoided.

7-6 静电容易破坏麦克风必须采取措施避免（电烙铁接地，戴静电环等。）

ECM may easily destroyed by the static electricity and the countermeasure for eliminating the static electricity (the ground for soldering copper, for worktable and for human body) shall be executed.

7-7 散热板形状 Shape of heat sink



7-8 固定部孔形状 Shape of hole at fixed part

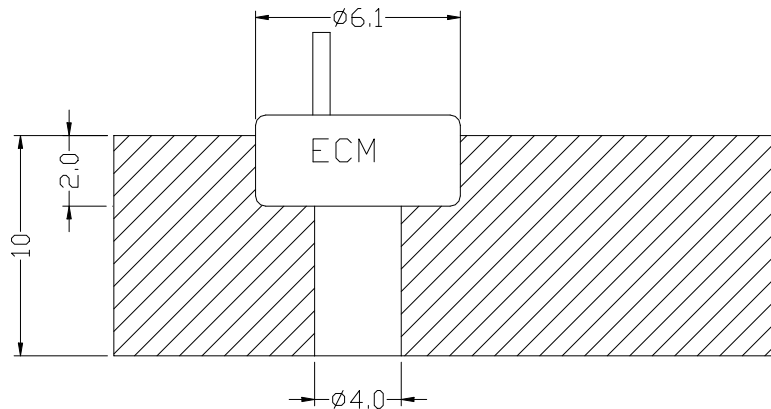

unit:mm