

GMI6050-2C 全指向驻积体咪头

详情说明

全指向性

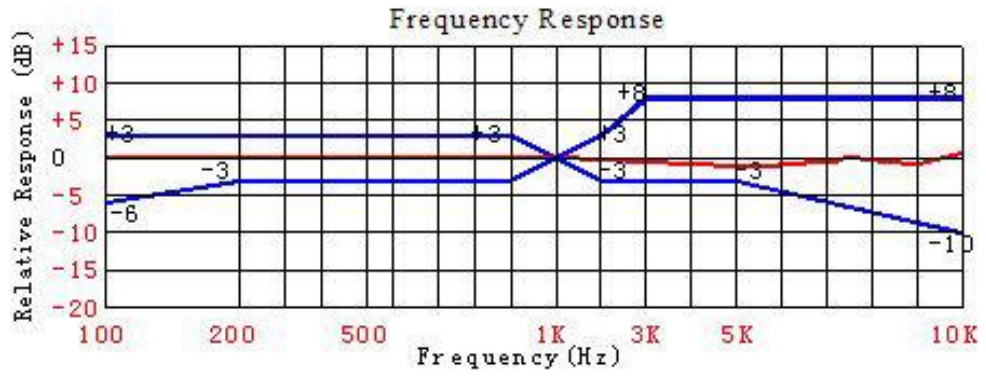

D. APPEARANCE DRAWING

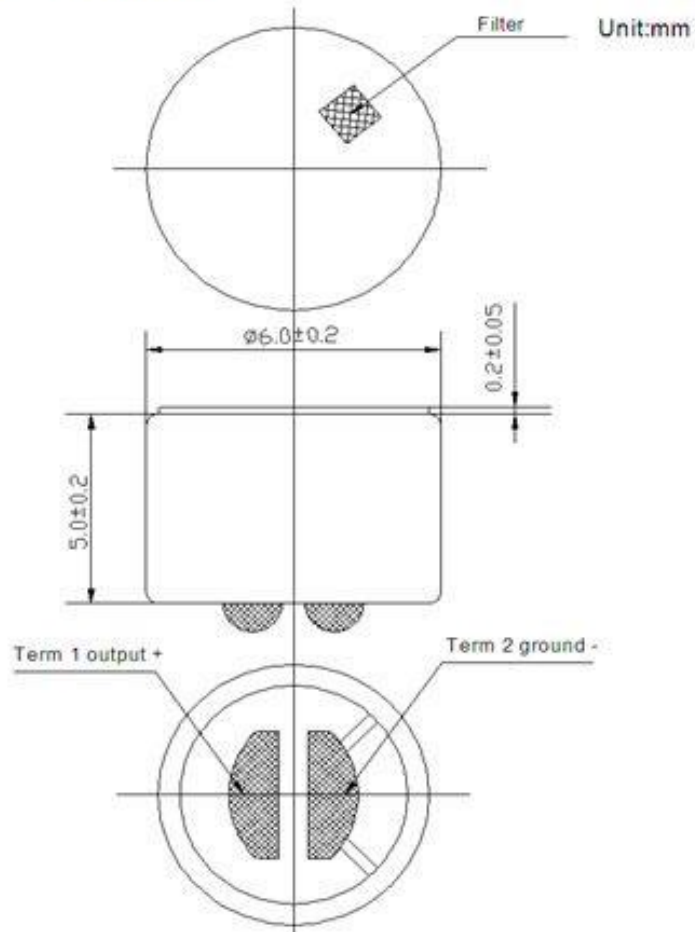

No.	Item	Symbol	Unit	Specification	Condition
1	Directivity			Omnidirectional	
2	Sensitivity	S	dB	-34~-44±3	0dB=1V/ Pa
3	Standard operating voltage	Vs	V	4.5	
4	Output impedance	Zout	KΩ	≤2.2	
5	Frequency		Hz	100-16,000	
6	Max operating voltage		V.	10	
7	Sensitivity reduction	ΔS-Vs	dB	-3	Vs=1.5VDC to 3.0VDC
8	Max. current consumption	IDSS	mA	≤0.5	
9	Signal to noise ration	S/N	dBA	≥58	
10	Max input sound level	SPL	dB	110	
11	Operation temp.		℃	-20 ~+70	
12	Storage temp.		℃	-40 ~+80	
13	Dimension		mm	∅ 6.0 x 5.0	See appearance drawing
14	Terminal			Terminal	See appearance drawing
15	Approvals			RoHs FCC	

We use "Pascal(Pa)" indication of sensitivity as per the recommendation of I.E.C.(International Electro technical Commission)

TheSensitivity of "Pa" will increase 20dB comparing with "ubar" indication

Example: -60dB(0dB=1V/ubar) =-40dB(1V/Pa)