

PART NUMBER	REVISION	DESCRIPTION	FEED TYPE
2266143-1	B	FINE CRIMP HEIGHT ADJUST	MECHANICAL
2266143-2	B	FINE CRIMP HEIGHT ADJUST	PNEUMATIC
7-2266143-1	B	MECHANICAL AND CRIMP TOOLING KIT	MECHANICAL
7-2266143-2	B	PNEUMATIC AND CRIMP TOOLING KIT	PNEUMATIC
7-2266143-7	A	CRIMP TOOLING KIT	-

ATLANTIC VERSION TERMINATOR INTERFACE ADAPTER

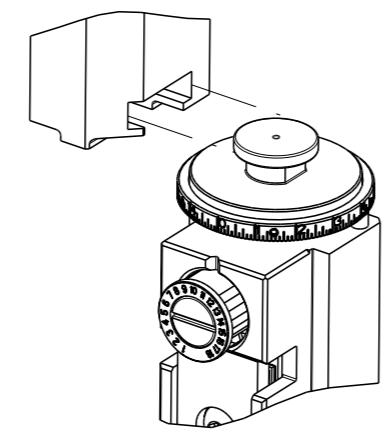

APPLICATOR DATA		
CRIMP	SIZE	TYPE
WIRE	1.27 mm [.050]	F
INSUL	1.78 mm [.070]	O

APPLICATOR INSTRUCTIONS
408-35042

TERMINAL DATA: HARTING TERMINAL TE CRIMP SPECIFICATION	
TERMINAL NAME: D-SUB, STAMPED M/F CONTACTS	
WIRE STRIP LENGTH 2.06-2.56 mm [.081-.101 IN]	INSULATION DIAMETER RANGE Ø1.30-1.60 mm [.051-.063 IN]
TERMINAL APPLICATION NONE	SPECIFICATION

TERMINALS APPLIED			
TE TERMINAL	HARTING TERMINAL	TE TERMINAL	HARTING TERMINAL
1572748-1	0967 000 8246	1572749-1	0967 000 8146
1572748-2	0967 000 8256	1572749-2	0967 000 8156
1572748-3	0967 000 8266	1572749-3	0967 000 8166
1572748-4	0967 000 8247	1572749-4	0967 000 8147
1572748-5	0967 000 8257	1572749-5	0967 000 8157
1572748-6	0967 000 8267	1572749-6	0967 000 8167
1572748-7	0967 000 8248	1572749-7	0967 000 8148
1572748-8	0967 000 8258	1572749-8	0967 000 8158
1572748-9	0967 000 8268	1572749-9	0967 000 8168

WIRE SIZE	CRIMP HEIGHT mm [INCH]	CRIMP HEIGHT REFERENCE SETTING
20 AWG	0.97+/-0.05 [.038+/-0.002]	6.2
22 AWG	0.84+/-0.05 [.033+/-0.002]	7.7
24 AWG	0.76+/-0.05 [.030+/-0.002]	8.6

- RECOMMENDED SPARE PARTS
- REFER TO SUPPLIED INSTRUCTION SHEET FOR CLEANING, LUBRICATION AND STORAGE OF APPLICATOR.
- APPLY PART NUMBER 2-23419-6 LOCTITE TO THREADS OF ITEM 242.
- CRIMP HEIGHT REFERENCE SETTING WAS THE SETTING USED WHEN THE APPLICATOR WAS QUALIFIED AT THE FACTORY. ADJUSTMENT MAY BE NECESSARY WHEN RUNNING APPLICATOR IN THE FIELD.
- UNLESS SPECIFIED OTHERWISE TORQUE VALUES SHALL BE USED PER DOCUMENT, 101-35000.
- USE ITEM 34, PART NUMBER 1752356-3 WITH SOCKET.
- USE ITEM 272, PART NUMBER 1752356-1 WITH PIN.

***WARNING**
ON INSTALLATION, SET WIRE DISC TO CRIMP HEIGHT REFERENCE SETTING FOR LARGEST WIRE SIZE. CRIMP HEIGHT REFERENCE SETTINGS GREATER THAN THE VALUE SHOWN MAY CAUSE DAMAGE TO THE CRIMP TOOLING, REFER TO THE INSTRUCTION SHEET FOR PROPER SETUP AND ADJUSTMENTS.

ATLANTIC VERSION
Shown on sheets 1 of 4 & 2 of 4
(Pacific version shown on sheets 3 of 4 & 4 of 4)

LOC	DIST	REVISIONS			
A	66	REV	DATE	BY	CHKD
		A	RELEASED	2006C2013	LG TE
		B	ECR-21-001903	17FEB2021	JAH RK

QTY	REF	REF	REF	REF	PART NO	DESCRIPTION	ITEM NO
1	-	1	1	1	1752356-1	SUPPORT, TERMINAL	272
1	-	1	1	1	2119641-1	FEED CAM, AIR FEED	248
1	-	1	1	1	2119082-8	CAM, SNAIL, INSULATION ADJUSTMENT	244
1	-	1	1	1	2079764-1	WASHER, WAVE SPRING, CREST-TO-CREST	243
1	-	1	1	1	2119083-1	RETAINER, INSULATION DIAL	242
1	-	1	1	1	7-18023-7	SCR, SKT HD CAP M3 X 4.0	241
1	-	1	1	1	2119580-1	MECHANICAL FEED ASSEMBLY	239
1	-	1	1	1	2844940-1	AIR FEED MODULE	238
1	REF	REF	REF	REF	994970-2	COUNTER, MAGNETIC	164
1	-	1	1	1	2844908-1	SCREW, LOCKING	99
1	-	1	1	1	2844907-1	POST, LOCKING	98
1	-	1	1	1	318563-1	GUARD, FRONT CHIP	89
1	-	1	1	1	1-455888-1	SPACER, CRIMPER	82
1	-	1	1	1	1803607-3	DOCUMENTATION PACKAGE	71
1	-	1	1	1	2119740-1	TAG, IDENTIFICATION	67
2	2	2	2	2	2168078-1	SCREW, DRIVE, RH, RoHS, 2 x .188	66
1	-	1	1	1	2168083-2	SCR, SKT HD CAP, RoHS, M4 X 8.0	60
1	-	1	1	1	5-18022-5	SCR, HEX HD CAP, M4 X 6.0	59
1	-	1	1	1	1338685-1	PAWL, FEED	56
4	4	4	4	4	2168083-3	SCR, SKT HD CAP, RoHS, M4 X 12.0	54
2	2	2	2	2	1-2168083-0	SCR, SKT HD CAP, RoHS, M4 X 10	53
1	-	1	1	1	5018030-1	NUT, HEX, REG, RoHS, M3	52
1	-	1	1	1	811242-5	BUMPER, HOLD DOWN	51
1	-	1	1	1	690753-2	SPACER, TONKER	50
1	-	2	1	2	18023-9	SCR, SKT HD CAP M4 X 6.0	49
1	-	1	1	1	2119652-1	FEED CAM, PRE FEED	48
1	-	1	1	1	2119653-1	FEED CAM, POST FEED	47
1	-	1	1	1	1803583-9	APPLICATOR BASIC ASSEMBLY, SF	46
1	-	1	1	1	1803515-1	RAM ASSEMBLY, SF ATLANTIC	44
1	-	1	1	1	1803602-1	SCR, BHSC, RoHS (M8 X 25)	41
1	-	1	1	1	1752356-3	SUPPORT, TERMINAL	34
2	2	2	2	2	2079383-5	SCR, BHSC, RoHS (M4 X 20)	33
2	2	2	2	2	2-2844962-3	SPACER, CYLINDRICAL, STRIP GUIDE	30
1	-	1	1	1	2844992-1	ASSEMBLY, STRIP GUIDE	29
1	-	1	1	1	1-455888-0	SPACER, CRIMPER	28
1	-	1	1	1	1320928-2	STRIP GUIDE	24
1	-	1	1	1	2168083-2	SCR, SKT HD CAP, RoHS, M4 X 8.0	21
1	-	1	1	1	1-18028-2	WASHER, FLAT, REG M4	20
1	-	1	1	1	2119533-1	STRIPPER, SIDE FEED	19
1	-	1	1	1	2119806-1	INSERT, SHEAR	13
1	-	1	1	1	3-22280-3	SPRING, COMPRESSION	12
1	-	1	1	1	1-356885-4	STOP, SHEAR	11
1	-	1	1	1	2119805-1	SHEAR HOLDER, FRONT	10
1	-	1	1	1	1803095-1	FLOATING SHEAR, FRONT	9
1	1	2	2	1	1803056-9	ANVIL, COMBINATION	8
-	-	-	-	-	-	-	7
-	-	-	-	-	-	-	6
1	-	1	1	1	2119757-8	DEPRESSOR, SHEAR	5
1	-	1	1	1	2-238011-0	BLOCK, CRIMPER SPACER	4
1	1	2	2	1	3-1803019-7	CRIMPER, INSULATION O	3
1	-	1	1	1	455888-2	SPACER, CRIMPER	2
1	1	2	2	1	2-568176-5	CRIMPER, WIRE	1

DIMENSIONS:		TOLERANCES UNLESS OTHERWISE SPECIFIED:		MATERIAL:	
mm	0 PLC ±	1 PLC ±	2 PLC ±	3 PLC ±	4 PLC ±
	ANGLES	FINISH			

OWN	29OCT2013	TE Connectivity
CHK	29OCT2013	Harrisburg, PA 17105-3608
APVD	29OCT2013	
NAME	Ocean Side Feed Applicator	
SIZE	CAGE CODE	DRAWING NO
A1	00779	2266143
Customer Accessible Production Drawing		SCALE 1:2 SHEET 1 OF 4 REV B

LOC	DIST	REVISIONS			
A	66	REV	DATE	OWN	APVD
-	SEE SHEET 1	-	-	-	-

FEED TYPE MECHANICAL

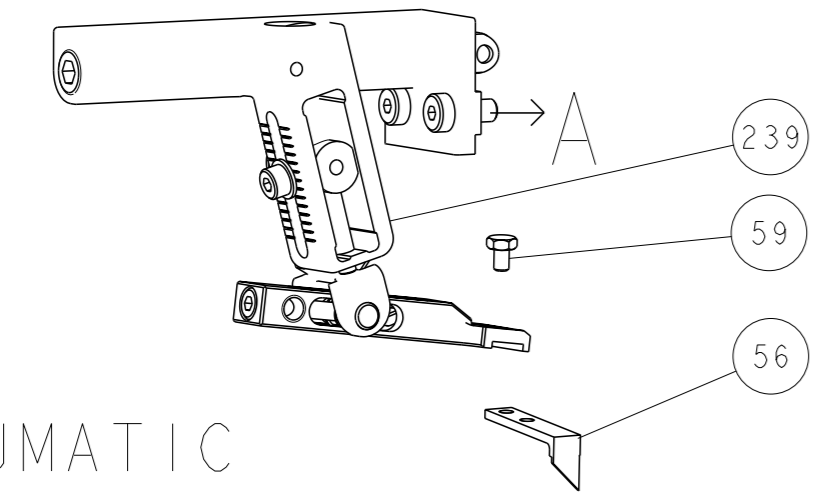

PNEUMATIC

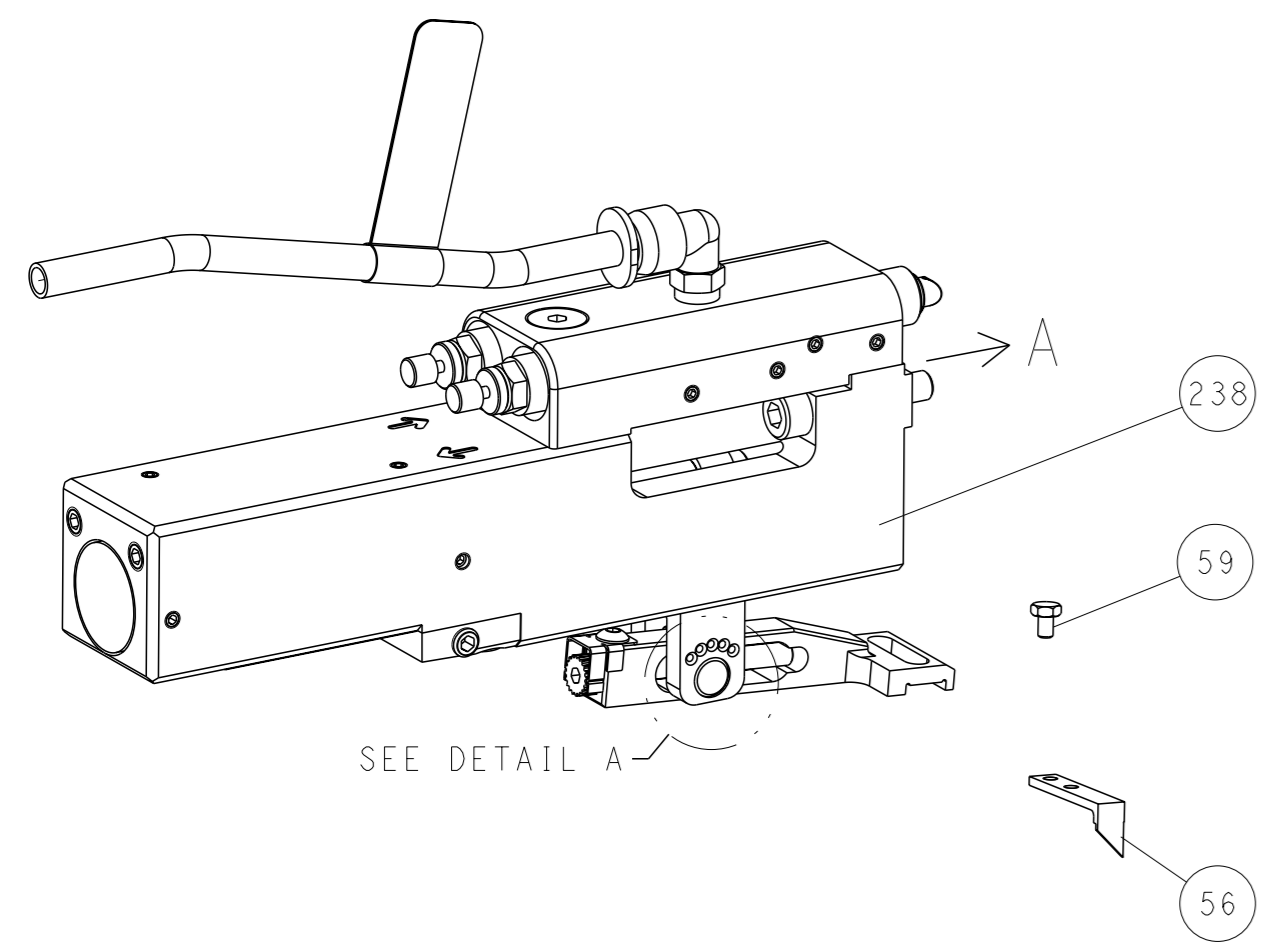

FEED SPRING SETTING POSITION (SHOWN FROM REAR SIDE)

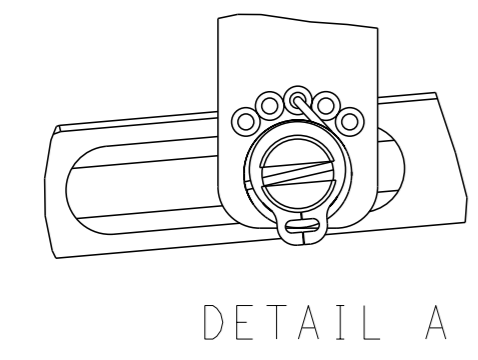

DETAIL A

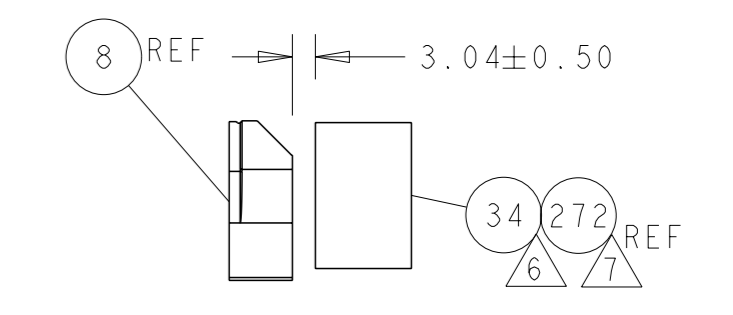
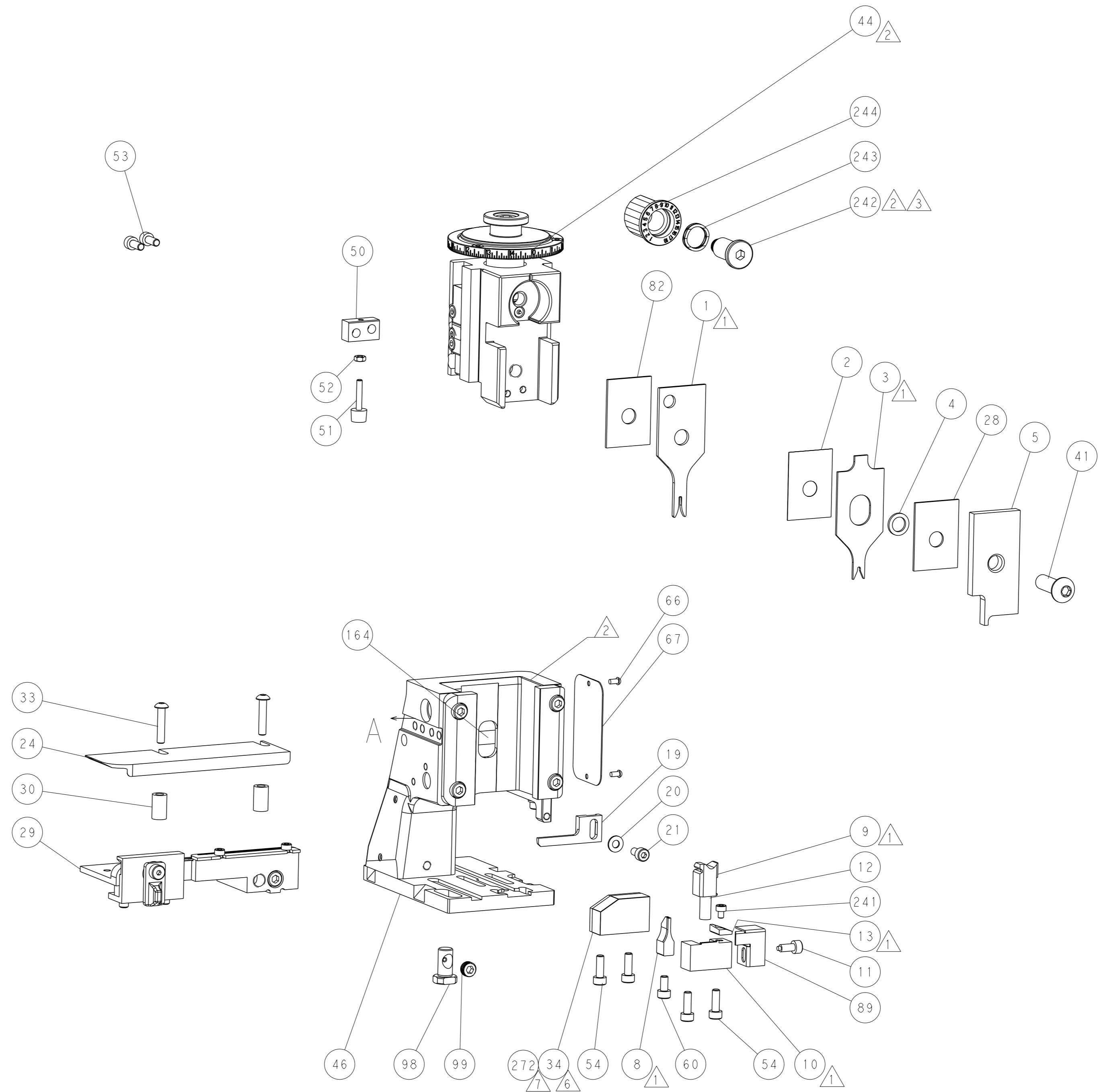

TERMINAL SUPPORT LOCATION

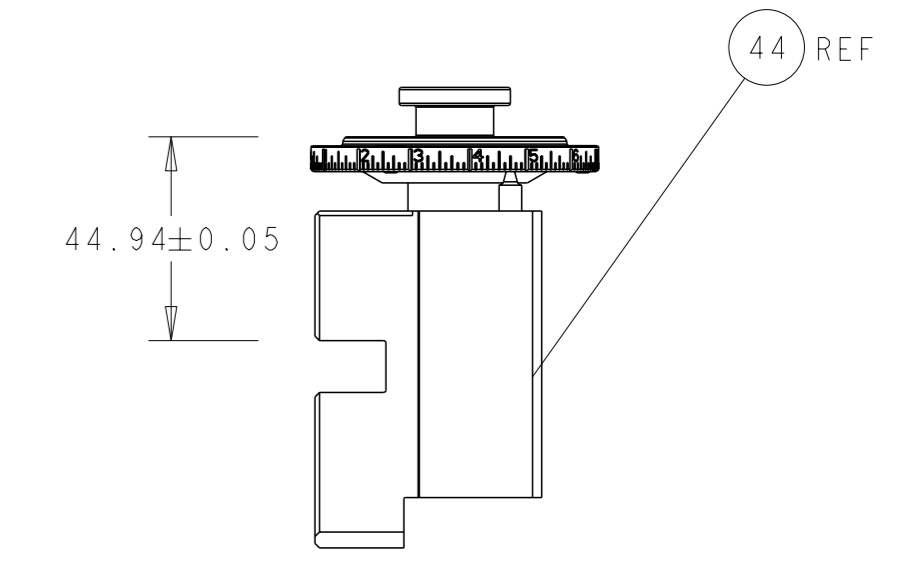

RAM SET-UP

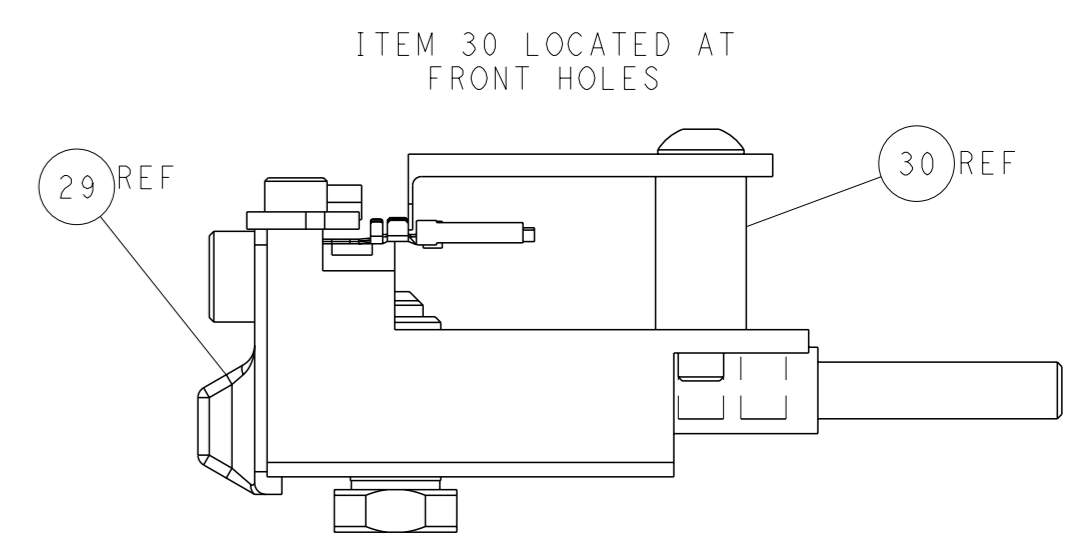

FEED TRACK POSITION GUIDE BY WIRE BARREL

CAM POSITIONS

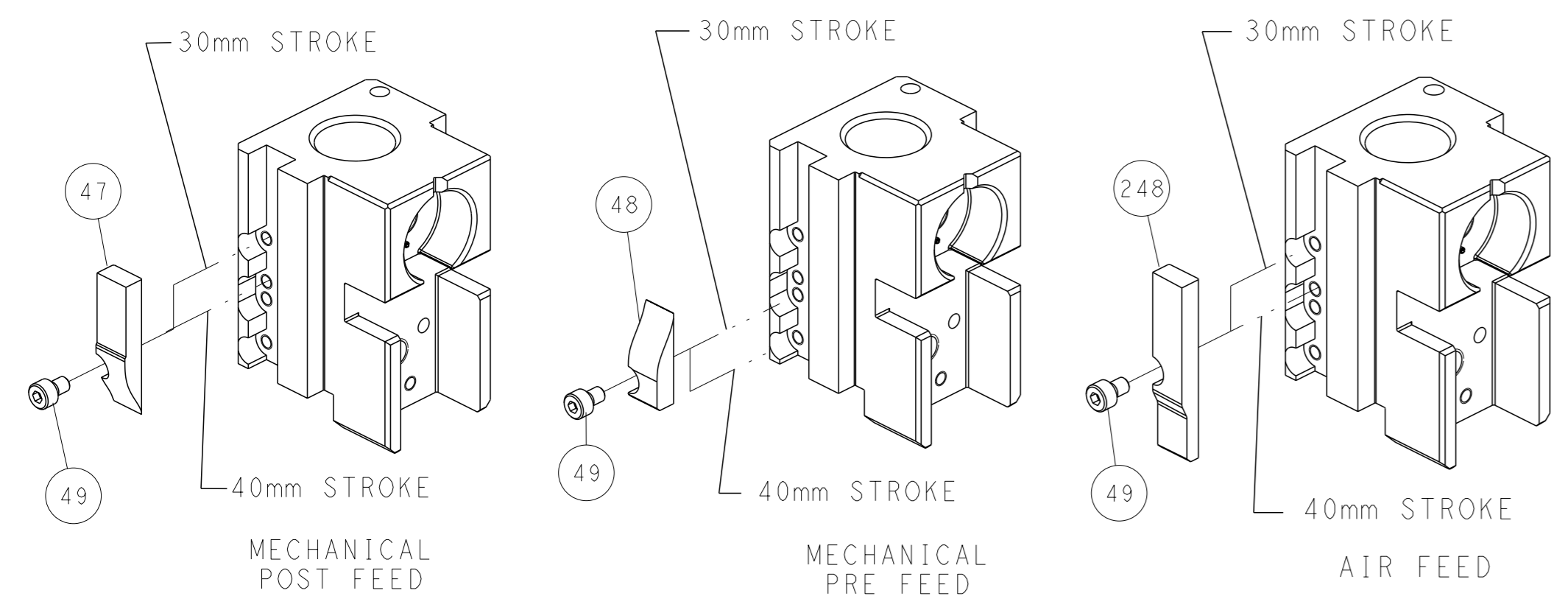

ATLANTIC VERSION
 Shown on sheets 1 of 4 & 2 of 4
 (Pacific version shown on sheets 3 of 4 & 4 of 4)

<small>THIS DRAWING IS A CONTROLLED DOCUMENT FOR TYCO ELECTRONICS CORPORATION. IT IS SUBJECT TO CHANGE AND TO CONTROL AND RESTRICTING DISPOSITION SHOULD BE CONTACTED FOR THE LATEST REVISION.</small>		DWN: 29OCT2013 CDR: T. ELBIN APVD: M. CLIFFORD PRODUCT SPEC: - APPLICATION SPEC: - WEIGHT: - MATERIAL: -	29OCT2013 29OCT2013 29OCT2013 - - - -	TE Connectivity Harrisburg, PA 17105-3608 NAME: Ocean Side Feed Applicator SIZE: A1 CAGE CODE: 00779 DRAWING NO: 2266143 SCALE: 1:2 SHEET: 2 of 4 REV: B	RESTRICTED TO: -
--	--	--	---	--	------------------

PART NUMBER	REVISION	DESCRIPTION	FEED TYPE
2-2266143-1	B	FINE CRIMP HEIGHT ADJUST	MECHANICAL
2-2266143-2	B	FINE CRIMP HEIGHT ADJUST	PNEUMATIC
7-2266143-7	A	CRIMP TOOLING KIT	-

PACIFIC VERSION TERMINATOR
INTERFACE ADAPTER

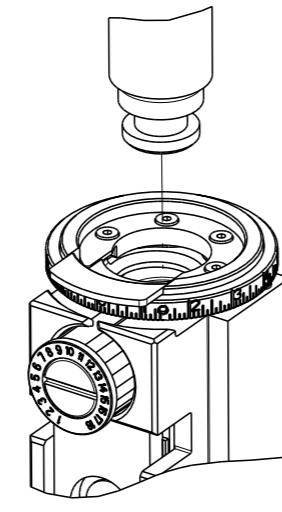

APPLICATOR DATA		
CRIMP	SIZE	TYPE
WIRE	1.27 mm [.050]	F
INSUL	1.78 mm [.070]	O

APPLICATOR INSTRUCTIONS
408-35042

TERMINAL DATA: HARTING TERMINAL TE CRIMP SPECIFICATION	
TERMINAL NAME: D-SUB, STAMPED M/F CONTACTS	
WIRE STRIP LENGTH	INSULATION DIAMETER RANGE
2.06-2.56 mm [.081-.101 IN]	∅1.30-1.60 mm [.051-.063 IN]
TERMINAL APPLICATION SPECIFICATION	NONE

TERMINALS APPLIED			
TE TERMINAL	HARTING TERMINAL	TE TERMINAL	HARTING TERMINAL
1572748-1	0967 000 8246	1572749-1	0967 000 8146
1572748-2	0967 000 8256	1572749-2	0967 000 8156
1572748-3	0967 000 8266	1572749-3	0967 000 8166
1572748-4	0967 000 8247	1572749-4	0967 000 8147
1572748-5	0967 000 8257	1572749-5	0967 000 8157
1572748-6	0967 000 8267	1572749-6	0967 000 8167
1572748-7	0967 000 8248	1572749-7	0967 000 8148
1572748-8	0967 000 8258	1572749-8	0967 000 8158
1572748-9	0967 000 8268	1572749-9	0967 000 8168

WIRE SIZE	CRIMP HEIGHT mm [INCH]	CRIMP HEIGHT REFERENCE SETTING
20 AWG	0.97+/-0.05 [.038+/-0.002]	6.2
22 AWG	0.84+/-0.05 [.033+/-0.002]	7.7
24 AWG	0.76+/-0.05 [.030+/-0.002]	8.6



- RECOMMENDED SPARE PARTS
- REFER TO SUPPLIED INSTRUCTION SHEET FOR CLEANING, LUBRICATION AND STORAGE OF APPLICATOR.
- APPLY PART NUMBER 2-23419-6 LOCTITE TO THREADS OF ITEM 242.
- CRIMP HEIGHT REFERENCE SETTING WAS THE SETTING USED WHEN THE APPLICATOR WAS QUALIFIED AT THE FACTORY. ADJUSTMENT MAY BE NECESSARY WHEN RUNNING APPLICATOR IN THE FIELD.
- UNLESS SPECIFIED OTHERWISE TORQUE VALUES SHALL BE USED PER DOCUMENT, 101-35000.
- USE ITEM 34, PART NUMBER 1752356-3 WITH SOCKET.
- USE ITEM 272, PART NUMBER 1752356-1 WITH PIN.

***WARNING**
ON INSTALLATION, SET WIRE DISC TO CRIMP HEIGHT REFERENCE SETTING FOR LARGEST WIRE SIZE. CRIMP HEIGHT REFERENCE SETTINGS GREATER THAN THE VALUE SHOWN MAY CAUSE DAMAGE TO THE CRIMP TOOLING, REFER TO THE INSTRUCTION SHEET FOR PROPER SETUP AND ADJUSTMENTS.

PACIFIC VERSION
Shown on sheets 3 of 4 & 4 of 4
(Atlantic version shown on sheets 1 of 4 & 2 of 4)

LOC	DIST	REVISIONS					
A	66	#	LY#	DESCRIPTION	DATE	OWN	APVD
-	-	-	-	SEE SHEET 1	-	-	-

-	1	1	1752356-1	SUPPORT, TERMINAL	272
-	1	1	2119082-8	CAM, SNAIL, INSULATION ADJUSTMENT	244
-	1	1	2079764-1	WASHER, WAVE SPRING, CREST-TO-CREST	243
-	1	1	2119083-1	RETAINER, INSULATION DIAL	242
-	1	1	7-18023-7	SCR, SKT HD CAP M3 X 4.0	241
-	-	-	2119580-1	MECHANICAL FEED ASSEMBLY	239
-	1	-	2844940-1	AIR FEED MODULE	238
-	REF	REF	994970-2	COUNTER, MAGNETIC	164
-	1	-	2119641-2	FEED CAM, AIR FEED	151
-	1	1	2168083-8	SCR, SKT HD CAP, RoHS, M4 X 16	144
-	4	4	2168083-9	SCR, SKT HD CAP, RoHS, M4 X 20	143
-	-	1	2119653-2	FEED CAM, POST FEED	142
-	1	1	1-1803583-0	APPLICATOR BASIC ASSEMBLY, SF	141
-	1	1	1803516-1	RAM ASSEMBLY, SF PACIFIC	140
-	1	1	2844908-1	SCREW, LOCKING	99
-	1	1	2844907-1	POST, LOCKING	98
-	1	1	318563-1	GUARD, FRONT CHIP	89
-	1	1	1-455888-1	SPACER, CRIMPER	82
-	1	1	1803607-3	DOCUMENTATION PACKAGE	71
-	1	1	2119740-1	TAG, IDENTIFICATION	67
-	2	2	2168078-1	SCREW, DRIVE, RH, RoHS, 2 x .188	66
-	1	1	5-18022-5	SCR, HEX HD CAP, M4 X 6.0	59
-	1	1	1338685-1	PAWL, FEED	56
-	2	2	1-2168083-0	SCR, SKT HD CAP, RoHS, M4 X 10	53
-	1	1	5018030-1	NUT, HEX, REG, RoHS, M3	52
-	1	1	811242-5	BUMPER, HOLD DOWN	51
-	1	1	690753-2	SPACER, TONKER	50
-	1	2	18023-9	SCR, SKT HD CAP M4 X 6.0	49
-	-	1	2119652-1	FEED CAM, PRE FEED	48
-	1	1	1803602-1	SCR, BHSC, RoHS (M8 X 25)	41
-	1	1	1752356-3	SUPPORT, TERMINAL	34
-	2	2	2079383-5	SCR, BHSC, RoHS (M4 X 20)	33
-	2	2	2-2844962-3	SPACER, CYLINDRICAL, STRIP GUIDE	30
-	1	1	2844992-1	ASSEMBLY, STRIP GUIDE	29
-	1	1	1-455888-0	SPACER, CRIMPER	28
-	1	1	1320928-2	STRIP GUIDE	24
-	1	1	2168083-2	SCR, SKT HD CAP, RoHS, M4 X 8.0	21
-	1	1	1-18028-2	WASHER, FLAT, REG M4	20
-	1	1	2119533-1	STRIPPER, SIDE FEED	19
-	1	1	2119806-1	INSERT, SHEAR	13
-	1	1	3-22280-3	SPRING, COMPRESSION	12
-	1	1	1-356885-4	STOP, SHEAR	11
-	1	1	2119805-1	SHEAR HOLDER, FRONT	10
-	1	1	1803095-1	FLOATING SHEAR, FRONT	9
-	1	1	1803056-9	ANVIL, COMBINATION	8
-	-	-	-	-	7
-	-	-	-	-	6
-	1	1	2119757-8	DEPRESSOR, SHEAR	5
-	1	1	2-238011-0	BLOCK, CRIMPER SPACER	4
-	1	1	3-1803019-7	CRIMPER, INSULATION O	3
-	1	1	455888-2	SPACER, CRIMPER	2
-	1	1	2-568176-5	CRIMPER, WIRE	1

DIMENSIONS:		TOLERANCES UNLESS OTHERWISE SPECIFIED:		MATERIAL:		FINISH:		WEIGHT:		SCALE:	
mm	0 PLC ±	1 PLC ±	2 PLC ±	3 PLC ±	4 PLC ±	ANGLES	FINISH	-	-	1:2	SHEET 3 OF 4

ITEM NO	PART NO	DESCRIPTION
-77-22-21		

OWN	29OCT2013	TE Connectivity
CHK	29OCT2013	Harrisburg, PA 17105-3608
APVD	29OCT2013	
NAME	Ocean Side Feed Applicator	
SIZE	CAGE CODE	DRAWING NO
A1	00779	2266143
Customer Accessible Production Drawing		

LOC		DIST		REVISIONS			
A	66	P	LYR	DESCRIPTION	DATE	OWN	APVD
		-		SEE SHEET 1	-	-	-

FEED TYPE MECHANICAL

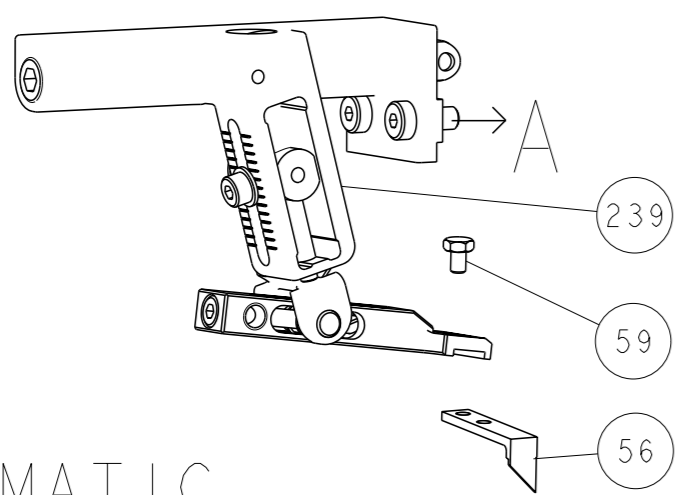

PNEUMATIC

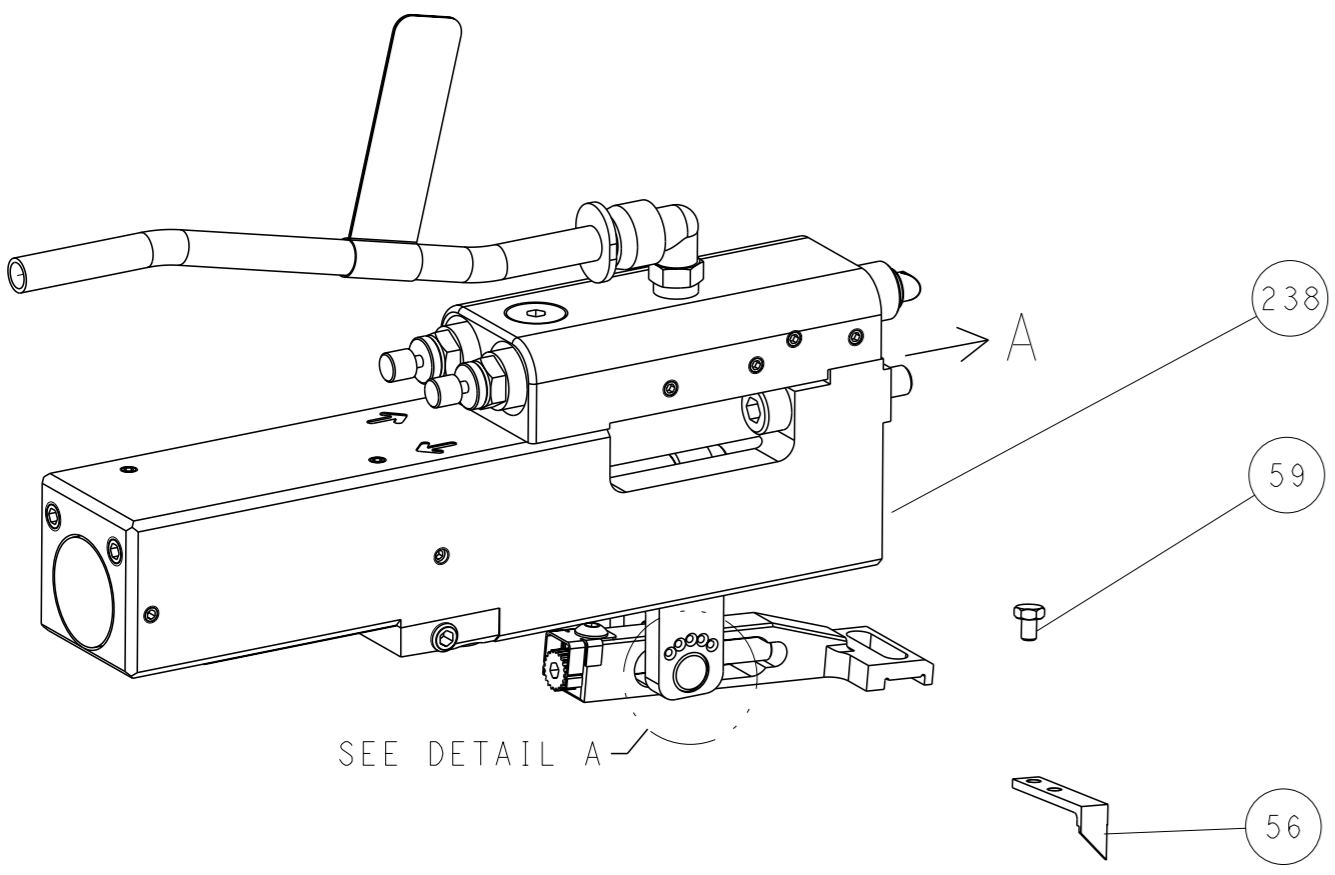

FEED SPRING SETTING POSITION (SHOWN FROM REAR SIDE)

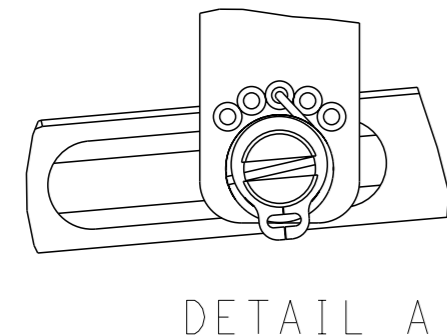

CAM POSITIONS

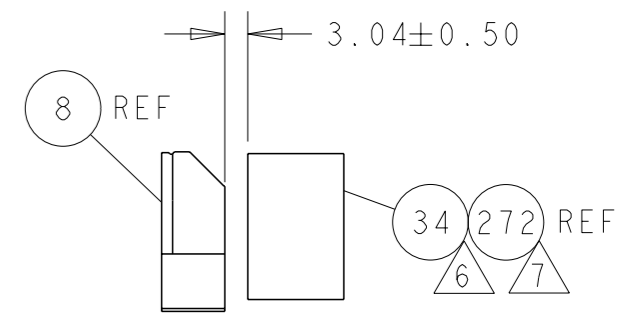
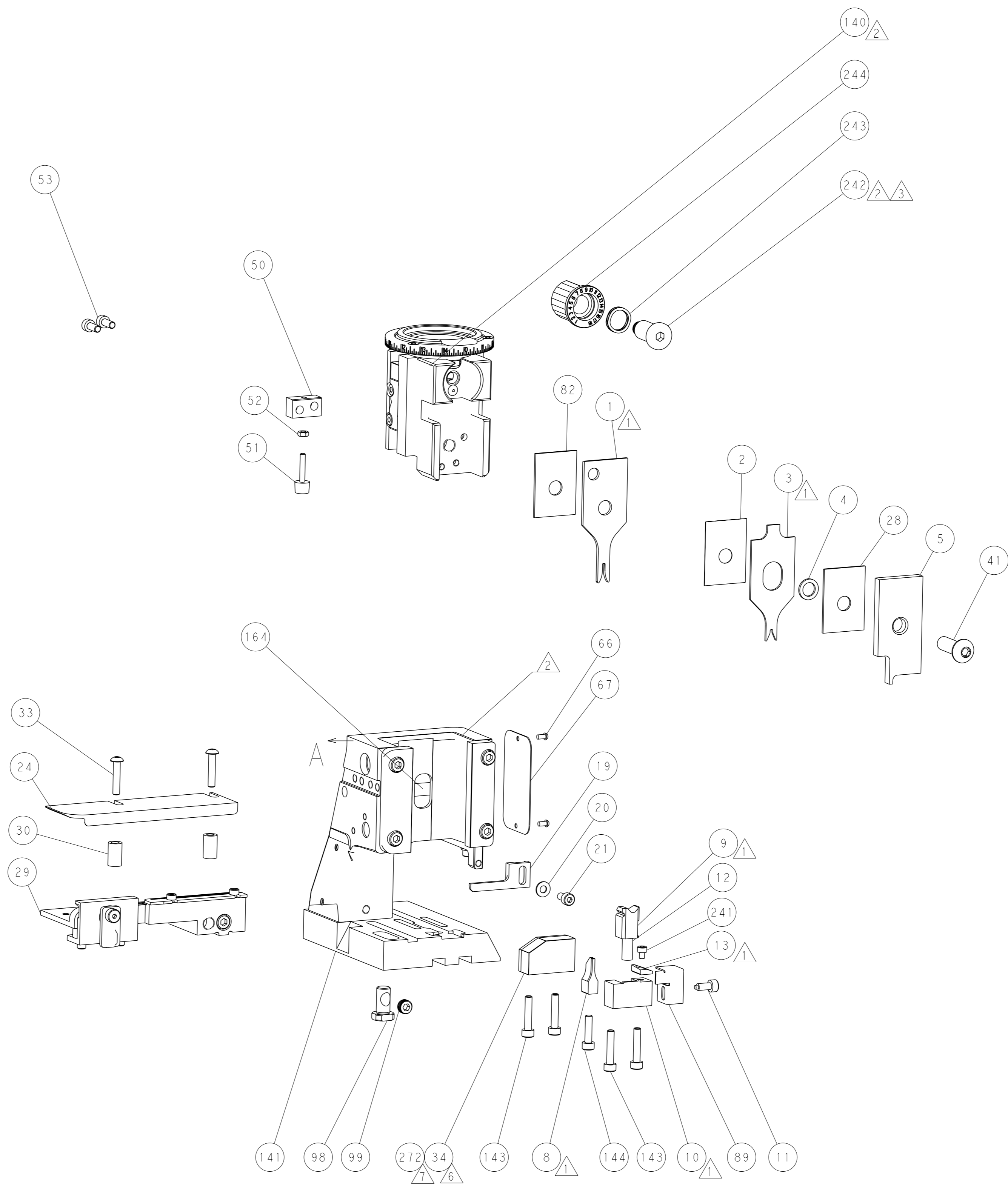
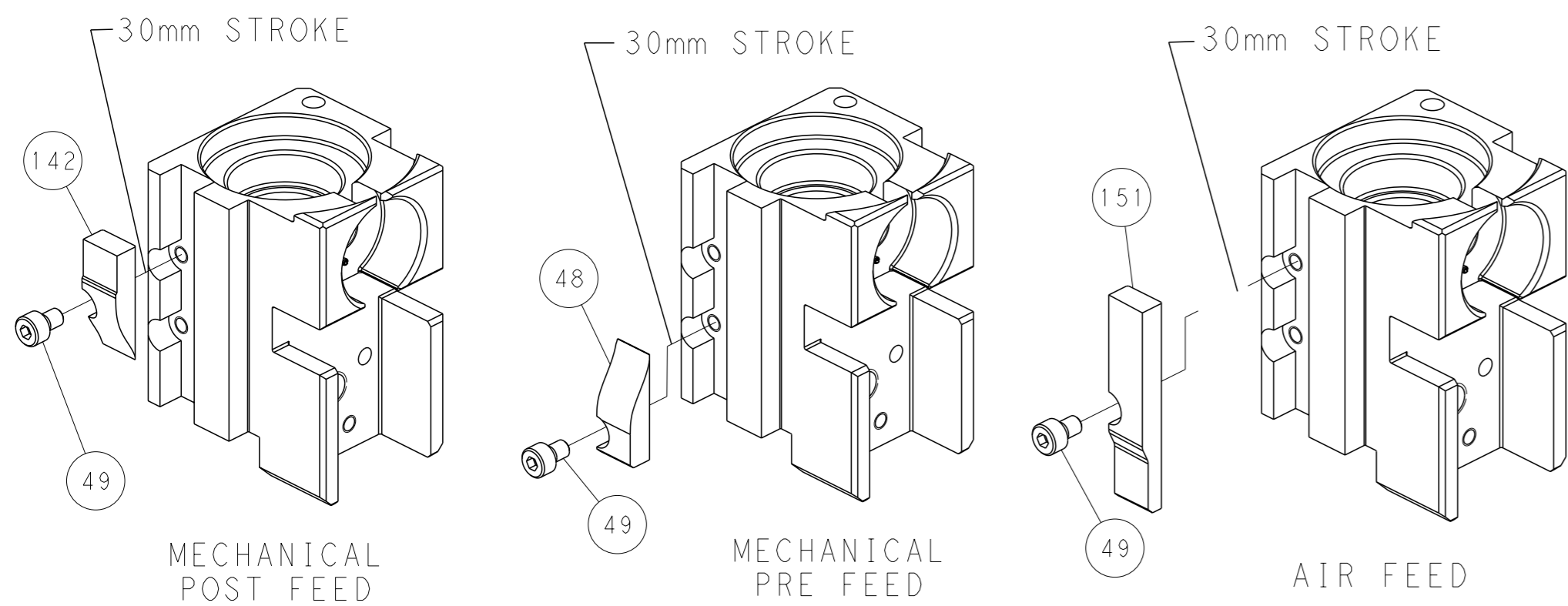

TERMINAL SUPPORT LOCATION

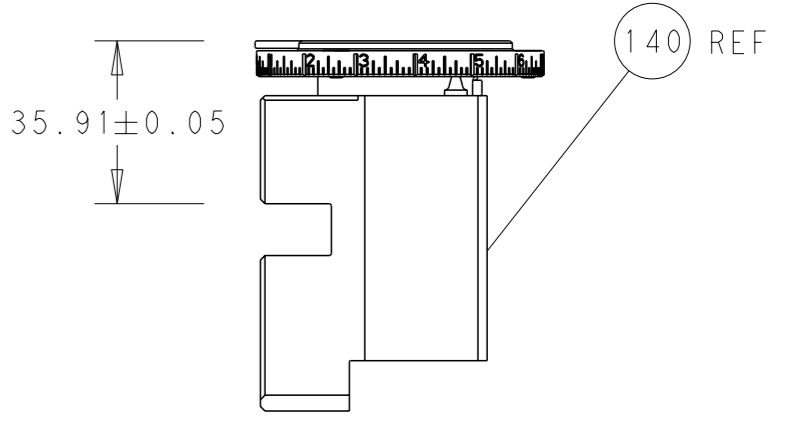

RAM SET-UP

ITEM 30 LOCATED AT FRONT HOLES

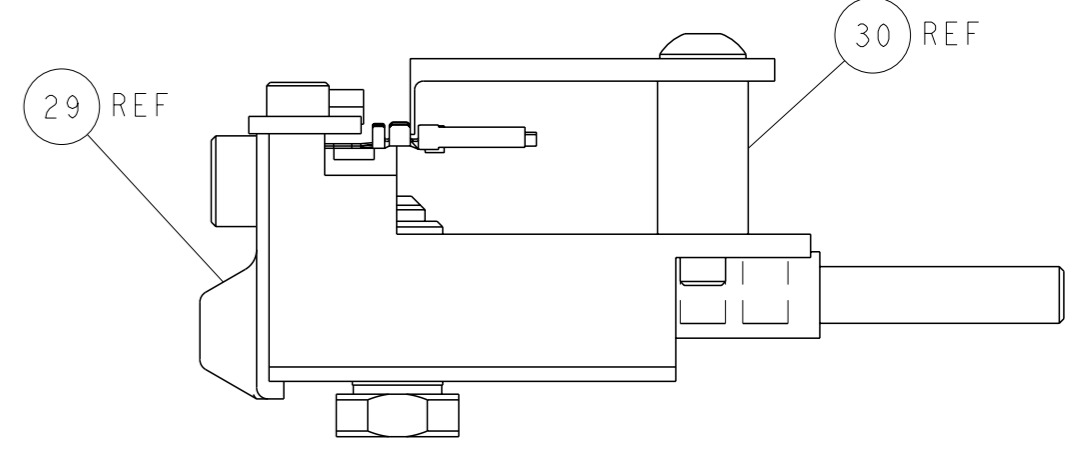

FEED TRACK POSITION GUIDE BY WIRE BARREL

PACIFIC VERSION
 Shown on sheets 3 of 4 & 4 of 4
 (Atlantic version shown on sheets 1 of 4 & 2 of 4)

<small>THIS DRAWING IS A CONTROLLED DOCUMENT FOR TYCO ELECTRONICS CORPORATION. IT IS SUBJECT TO CHANGE AND THE USER MUST CONTACT THE DESIGNATION SHOULD BE CONTACTED FOR THE LATEST REVISION.</small>		OWN: L. GROSS CHK: T. ELBIN APVD: M. CLIFFORD PRODUCT SPEC: - APPLICATION SPEC: - MATERIAL: - FINISH: -	SIZE: A1 CAGE CODE: 00779 DRAWING NO: C-2266143 SCALE: 1:2 SHEET: 4 of 4 REV: B	NAME: Ocean Side Feed Applicator RESTRICTED TO: -
DIMENSIONS: mm 0 PLC ± 1 PLC ± 2 PLC ± 3 PLC ± 4 PLC ± ANGLES ± FINISH ±		TOLERANCES UNLESS OTHERWISE SPECIFIED: ± ± ± ± ± ±	DATE: 29OCT2013 NAME: M. CLIFFORD WEIGHT: - CUSTOMER ACCESSIBLE PRODUCTION DRAWING: -	DATE: 29OCT2013 NAME: M. CLIFFORD WEIGHT: - CUSTOMER ACCESSIBLE PRODUCTION DRAWING: -