

# 深圳市能點科技有限公司

SHENZHEN EPT TECHNOLOGY CO., LTD.

## 規格書 SPECIFICATION



**DFS-IR1907**

分離式光電液位感測器

Single-point photoelectric level sensor



版本 Version : A-L

日期 Date : 2019.05.18

[www.eptsz.com](http://www.eptsz.com)

## 目錄頁/Table of Content

1. 修訂記錄/Revision History
2. 應用領域/Application
3. 產品特徵/General Features
4. 電氣參數特性/Electrical Specification
5. 推薦應用電路/Recommended Application Circuit
6. 應用及檢測/Application & Detection
7. 包裝/ Package
8. 尺寸和推薦安裝/Outline Drawing and Recommended installation



本規格書為相應產品作業之標準，在客戶確認後，會作為生產、供貨的依據。如有特殊要求，可告知联系你的市场部人员，并出具承认书。

This specification is the standard for the operation of the corresponding products. It will be used as the basis for production and supply after confirmation by the customer. If you have special requirements, please contact our sales and issue an acknowledgement.



## 2. 應用領域/Application

飲水機/ Water dispenser

熱水器/Water heater

加濕器/Humidifier

咖啡機/Coffee machine

醫療設備/Medical devices or equipment

需要偵測液體的電器，設備等/Electrical appliances and equipment's etc. requiring liquid-level control

## 3. 產品特徵/Product features

無機械運動部件、可靠性高

No mechanical moving components and with high reliability

體積小、成本低

Small in size and low in cost

液位控制精度高

Satisfying the requirements in Safety Standards

符合 RoHS 要求

The sensor itself satisfies RoHS requirements

防水等級 IP67

Waterproofing standard IP67

## 4. 電氣參數特性/ Electrical Specification ( Ta=25°C )

參數/Parameter	符號/Symbol	條件/Condition	最小值/Min	典型/Typ	最大值/Max	單位/Units	
直流特性 direct-current characteristic	工作電壓/Working Voltage	VDD	4.9	5	5.5	V	
	電流/current	IDD	VDD = 5V 有水狀態/in water	10	15	20	mA
			VDD = 5V 無水狀態/in air	15	20	25	mA
	消耗功率 power consumption	PD	VDD = 5V 有水狀態/in water	50	75	100	mW
VDD = 5V 無水狀態/in air			75	100	125	mW	
輸出特性 output characteristic	有水狀態輸出電壓/Voltage when in water	VO1	VDD = 5V Ta = 25°C	—	<0.3	—	V
	無水狀態輸出電壓/Anhydrous output voltage	VO2	VDD = 5V Ta = 25°C	—	>4.0	—	V
	輸出源電流/output current	IOL	VDD = 5V Ta = 25°C	—	<2	—	mA
	輸出灌電流/output current	IOH	VDD = 5V Ta = 25°C	—	<2	—	mA
	響應時間/response time		VDD = 5V Ta = 25°C	—	100	—	uS
極限值/limit value	工作溫度/Operating Temperature	Topr	VDD = 5V	-20	—	85	°C
	儲存溫度/Storage Temperature	Tstg	—	-20	—	85	°C
	工作壽命/Working Time	Wt	VDD = 5V Totg = 25°C	—	50000	—	h
	壓力範圍/pressure range			-10	5	10	bar



本規格書為相應產品作業之標準，在客戶確認後，會作為生產、供貨的依據。如有特殊要求，可告知联系你的市场部人员，并出具承诺书。

This specification is the standard for the operation of the corresponding products. It will be used as the basis for production and supply after confirmation by the customer. If you have special requirements, please contact our sales and issue an acknowledgement.

## 5. 推薦應用電路/Recommended Application Circuit

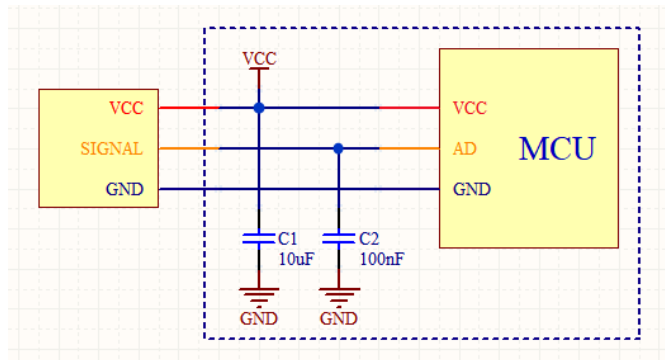

## 6. 應用及檢測/Application & Detection

將液位感測器按下述方式之一安裝，再將其按如上電路連接，信號端將輸出與水位狀況一致的電壓信號，此信號作為液位感測器高度控制信號接入 MCU（單片機）A/D（模數轉換）埠，當液位超過臨界液位而淹沒感測器本體時，此時信號輸出為低電壓，當液位低於臨界液位而顯露感測器本體時，此時信號輸出為高電壓，具體參數如上表所示。

Install level sensor according to one of the mentined modes and connect it according to above circuit, the signal end will output voltage signal consistent with the water level, the signal will be accessed to MCU or A/D port. When the level is over the critical level and the sensor body is submerged, output signal is low vottage; When the level is below the critical level and the sensor body is exposed, output signal is high voltage. Please refer to specific parameters as above table.

### 注意：

- 當被探測液體為水，水位高度低於臨界液位時，水汽、水蒸汽或水珠會在感測器本體表面集結，從而導致信號輸出電壓下降。所以在實際應用時，考慮到水汽、水蒸汽或水珠的影響，將感測器閾值電壓設值為  $V_T$ ，即信號端輸出電壓如果大於  $V_T$ ，則判斷液位低於臨界液位，信號端輸出電壓如果小於  $V_T$ ，則判斷液位高於臨界液位。  
 $V_T$ 一般取值為 0.3—0.5V，具體數值根據水汽、水蒸汽或水珠的產生以及影響程度來確定。當被探測液體為其它時，也會受到水珠的影響，故也按此法考慮。
- 考慮到液面的波動特性，如果波動性較大，且波動幅度 > 1MM，在程式中要加入防抖邏輯。
- 長期使用過程中，稜鏡表面因液體雜質產生污垢，輕微的污垢不會影響到感測器的效能，如有嚴重的污垢產生，導致稜鏡整體覆蓋，需要提前告知特殊性，以便我方技術部做優化處理。
- 感測器在陽光直射下會受到干擾，請安裝在避免陽光照射的位置內。

1. In practical application, taking into consideration of the influence of steam and dirt, the liquid level threshold voltage is set as  $V_T$ , that is, if the output voltage of signal end is higher than  $V_T$ , the liquid level is decided to be lower than the critical liquid level; and if the output voltage of signal end is lower than  $V_T$ , the liquid level is decided to be higher than the critical liquid level.  $V_T$  is set between 0.3 and 0.5 V, and the specific value is determined by the generation speed of dirt.

2. Considering the fluctuation characteristics, if the fluctuation is large and the fluctuation range is more than 1MM, the anti-shake logic should be added to the program.

3. During long-term use, the surface of the prism will be stained due to liquid impurities. Slight dirt will not affect the performance of the sensor. If serious dirt is generated, the overall coverage of the prism will need to be notified in advance so that our technical department can do it. Optimize processing.

4. The sensor will be effected when exposed to direct sunlight. Please install it away from direct sunlight.



本規格書為相應產品作業之標準，在客戶確認後，會作為生產、供貨的依據。如有特殊要求，可告知联系你的市场部人员，并出具承诺书。

This specification is the standard for the operation of the corresponding products. It will be used as the basis for production and supply after confirmation by the customer. If you have special requirements, please contact our sales and issue an acknowledgement.

## 7. 包裝/ Package

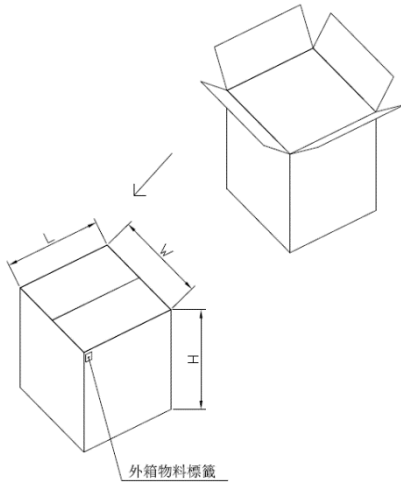

說明：

1. 外箱尺寸：34X27.5X33.5 CM

1箱產品數量：800 PCS

2. 包裝盒尺寸：33.5X13.5X8 CM

1盒產品數量：100 PCS

Description:

1. Outer box size: 34X27.5X33.5 CM  
one box product quantity: 800 PCS

2. Packing box size: 33.5X13.5X8 CM  
one box of products: 100 PCS

## 8. 尺寸和推薦安裝/Outline Drawing and Recommended installation

EPT TECHNOLOGY CO., LTD.



本規格書為相應產品作業之標準，在客戶確認後，會作為生產、供貨的依據。如有特殊要求，可告知联系你的市场部人员，并出具承认书。

This specification is the standard for the operation of the corresponding products. It will be used as the basis for production and supply after confirmation by the customer. If you have special requirements, please contact our sales and issue an acknowledgement.

1 2 3 4 5 6

A

A

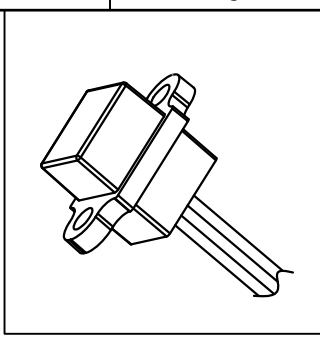

B

B

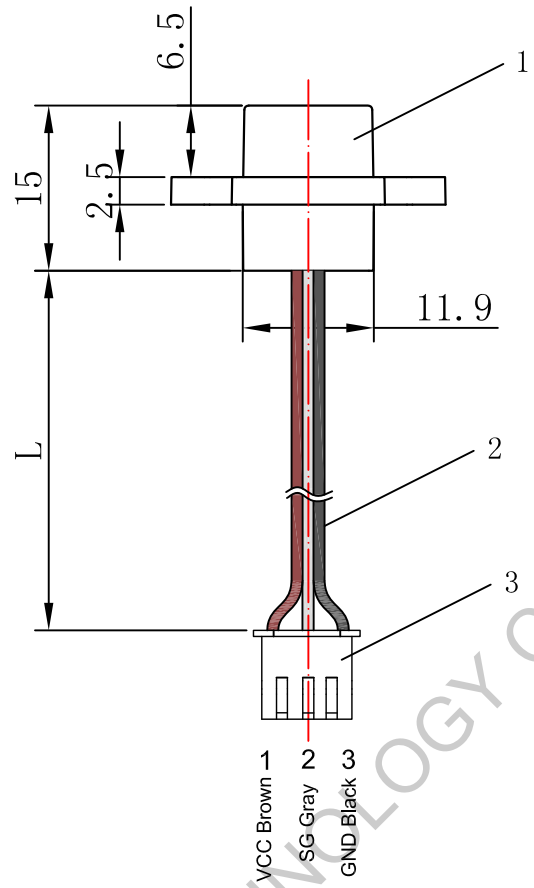

C

C

D

D

E

E

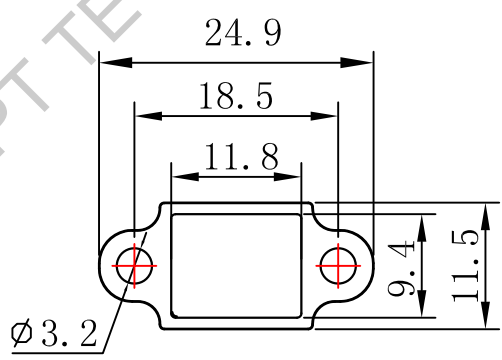

F

F

耐溫 Temperature resistance	*	耐壓 Withstand voltage	*
鍍錫 Tin plating	*	長度 Length	*
UL線規 UL wire gauge	*	UL編號 UL number	*
顏色 Colour	Black	線號 Line number	*
線材規格 Wire specification			

腳距 Foot distance	2.54	孔數 Number of holes	3
顏色 Colour	White	型號 Model	XHB
端子規格 Terminal Specifications			

3	端子 Terminal	1	
2	線材 Wire	1	
1	感測器主體 Sensor body	1	
編號 NO.	名稱 Name	數量 QTY	備註 P.S.

G

G

設計 Designer	Zhou	材料 Material	*	單位 Unit	mm
檢查 Checked	Zhou	表面處理 Finish	*	比例 Scale	*
審批 Approver	Wei	數量 Quantity	*	篇幅 Size	A4
一般公差 Tolerances	0-10	±0.25	0.8	備註 Remarks	*
	10-35	±0.35		視圖 View	
	35-70	±0.45			



能點科技有限公司  
EPT technology co., LTD

產品名 Product Name	DFS-IR1907	日期 Date	19-05-18
頁面內容 Page content	產品圖	版本 REV	A
圖號 DWG NO.	*	頁數 Pages No.	1/2

1 2 3 4 5 6

H

H

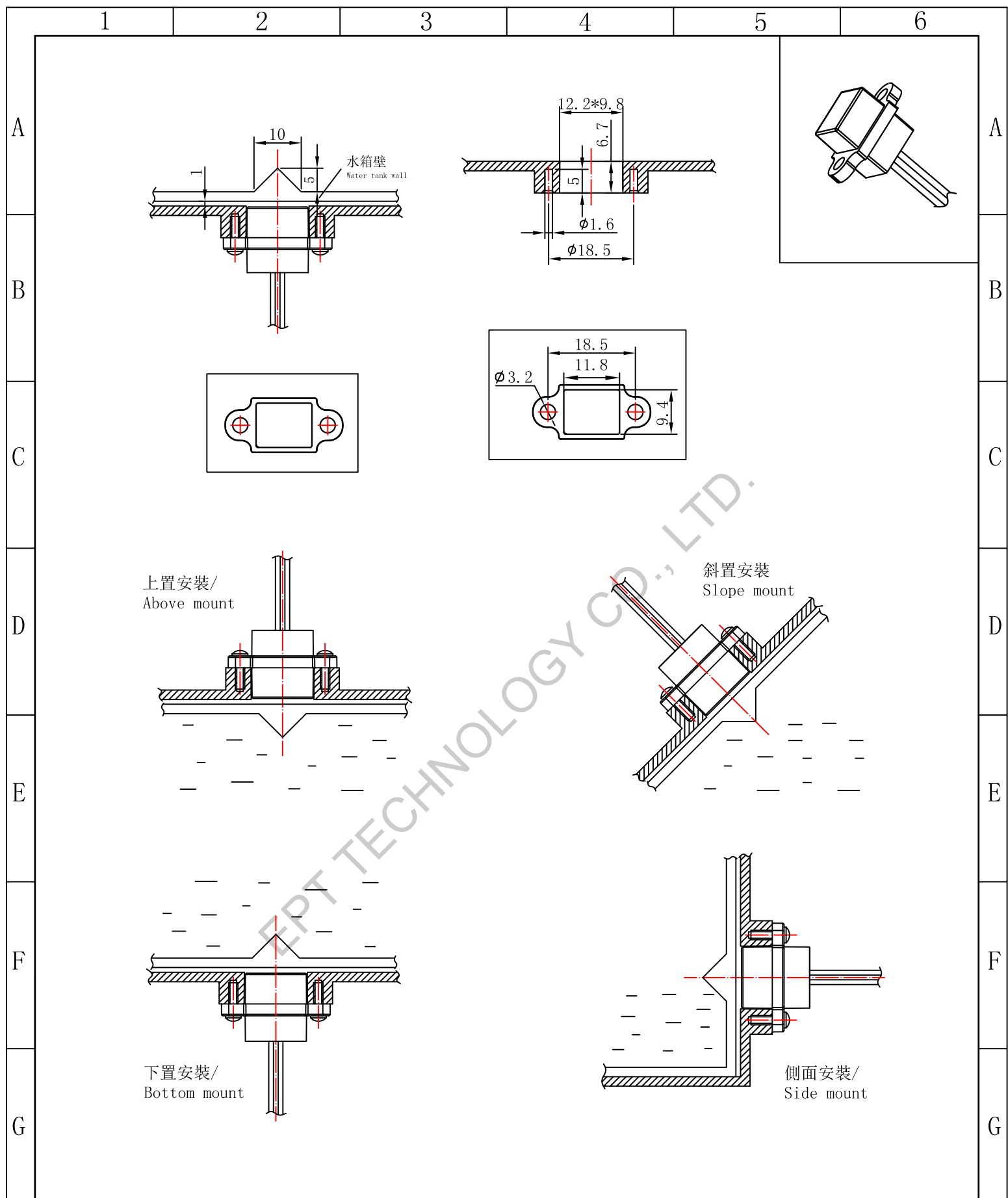

設計 Designer	Zhou	材料 Material	*	單位 Unit	mm	 <b>能點科技有限公司</b> EPT technology co., LTD			
檢查 Checked	Zhou	表面處理 Finish	*	比例 Scale	*				
審批 Approver	Wei	數量 Quantity	*	篇幅 Size	A4	產品名 Product Name	DFS-IR1907	日期 Date	19-05-18
一般公差 Tolerances	0-10	±0.25	0.8	備註 Remarks	*	頁面內容 Page content	產品安裝示意圖	版本 REV	A
	10-35	±0.35				圖號 DWG NO.	*	頁數 Pages NO.	2/2
	35-70	±0.45							