

PART NUMBER	REVISION	DESCRIPTION	FEED TYPE
2150296-2	D	FINE CRIMP HEIGHT ADJUST	PNEUMATIC
7-2150296-2	D	PNEUMATIC AND CRIMP TOOLING KIT	PNEUMATIC
7-2150296-7	A	CRIMP TOOLING KIT	-

ATLANTIC VERSION TERMINATOR INTERFACE ADAPTER

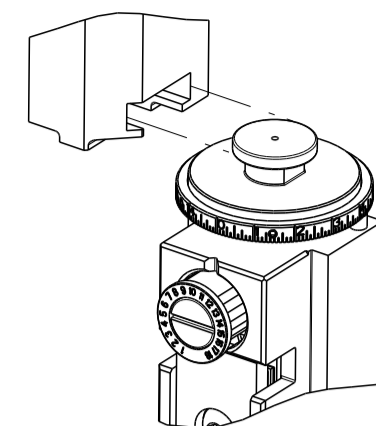

APPLICATOR DATA		
CRIMP	SIZE	TYPE
WIRE	3.56 mm [.140]	F
INSUL	4.57 mm [.180]	F
APPLICATOR INSTRUCTIONS 408-35043		

TERMINAL DATA: TE TERMINAL		TE CRIMP SPECIFICATION	
TERMINAL NAME: RINGTONGUE WITH INS SUPPORT			
WIRE STRIP LENGTH		INSULATION DIAMETER RANGE	
4.80-5.60 mm [.189-.220 IN]		∅2.54-3.81 mm [.100-.150 IN]	
TERMINAL APPLICATION SPECIFICATION	114-3118		
TERMINALS APPLIED			
TE TERMINAL	TE TERMINAL	TE TERMINAL	TE TERMINAL
160789-2	160789-3	160789-5	

WIRE SIZE	CRIMP HEIGHT mm [INCH]	CRIMP HEIGHT REFERENCE SETTING
2.50mm2	2.29+/-0.05 [.090+/-0.002]	4.4
2.00mm2	2.18+/-0.05 [.086+/-0.002]	5.7
1.50mm2	2.06+/-0.05 [.081+/-0.002]	7.0
1.00mm2	1.96+/-0.05 [.077+/-0.002]	8.0

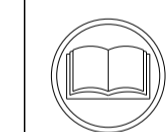

- 1 RECOMMENDED SPARE PARTS
- 2 REFER TO SUPPLIED INSTRUCTION SHEET FOR CLEANING, LUBRICATION AND STORAGE OF APPLICATOR.
- 3 APPLY PART NUMBER 2-23419-6 LOCTITE TO THREADS OF ITEM 242.
- 4 CRIMP HEIGHT REFERENCE SETTING WAS THE SETTING USED WHEN THE APPLICATOR WAS QUALIFIED AT THE FACTORY. ADJUSTMENT MAY BE NECESSARY WHEN RUNNING APPLICATOR IN THE FIELD.
- 5 UNLESS SPECIFIED OTHERWISE TORQUE VALUES SHALL BE USED PER DOCUMENT, 101-35000.
- 6 TERMINAL PITCH NOT COMPATIBLE WITH MECHANICAL FEED.

***WARNING**
ON INSTALLATION, SET WIRE DISC TO CRIMP HEIGHT REFERENCE SETTING FOR LARGEST WIRE SIZE. CRIMP HEIGHT REFERENCE SETTINGS GREATER THAN THE VALUE SHOWN MAY CAUSE DAMAGE TO THE CRIMP TOOLING. REFER TO THE INSTRUCTION SHEET FOR PROPER SETUP AND ADJUSTMENTS.

LOC	DIST	REVISIONS					
A	66	P	LTN	DESCRIPTION	DATE	DWN	APVD
		A		RELEASE	21NOV2012	L.Z	S.X
		B		ECR-13-000120	04JAN2012	L.Z	S.X
		C		ECR-14-002390	18FEB2014	X.Z	T.E
		D		ECR-19-003764	08MAR2019	TB	CT

-	1	1	2119640-1	PUSH ROD, AIR FEED	250	
-	1	1	1803259-1	BUSHING, FLANGED	249	
-	1	1	2119641-1	FEED CAM, AIR FEED	248	
-	1	1	2119082-9	CAM, SNAIL, INSULATION ADJUSTMENT	244	
-	1	1	2079764-1	WASHER, WAVE SPRING, CREST-TO-CREST	243	
-	1	1	2119083-1	RETAINER, INSULATION DIAL	242	
-	1	1	2063440-2	AIR FEED MODULE	238	
-	1	1	1-18028-0	WASHER, FLAT, REG M8	192	
-	2	2	21045-3	RING, RETAIN, EXTERN, 3/16 CRESCENT	172	
-	REF	REF	994970-2	COUNTER, MAGNETIC	164	
-	1	1	240638-1	SPRING, FEED FINGER	163	
-	1	1	3-23627-7	PIN, RETAIN, GRVD, 3/16 X .854	137	
-	1	1	455888-5	SPACER, CRIMPER	82	
-	1	1	1803607-2	DOCUMENTATION PACKAGE	71	
-	2	2	2-18032-2	SCR, SET, FLT PNT, M3 X 10.0	70	
-	1	1	2119740-1	TAG, IDENTIFICATION	67	
-	2	2	2168078-1	SCREW, DRIVE, RH, RoHS, 2 x .188	66	
-	1	1	2168083-2	SCR, SKT HD CAP, RoHS, M4 X 8.0	60	
-	4	4	2168400-4	SHCS, LOW HEAD, RoHS, M4 X 8	57	
-	2	2	2-2168083-6	SCR, SKT HD CAP, RoHS, M4 X 18	56	
-	2	2	5018030-1	NUT, HEX, REG, RoHS, M3	54	
-	2	2	986965-8	NUT, LOCK, HEX, TORQUE (M4)	53	
-	1	1	2119792-2	PAWL, EF, AIR	51	
-	1	1	18023-9	SCR, SKT HD CAP M4 X 6.0	49	
-	1	1	2119655-5	APPLICATOR BASIC ASSEMBLY, EF	46	
-	1	1	1803517-1	RAM ASSEMBLY, EF ATLANTIC	44	
-	1	1	1803602-1	SCR, BHSC, RoHS (M8 X 25)	41	
-	8	8	1-18028-2	WASHER, FLAT, REG M4	33	
-	2	2	2168083-9	SCR, SKT HD CAP, RoHS, M4 X 20	31	
-	2	2	2168083-2	SCR, SKT HD CAP, RoHS, M4 X 8.0	29	
-	1	1	240639-1	STRIPPER (MACHINING)	27	
-	2	2	1-2168083-5	SCR, SKT HD CAP, RoHS, M4 X 30	25	
-	1	1	1752371-1	PLATE, STRIP GUIDE	24	
-	2	2	3-22281-8	SPRING, COMPRESSION	22	
-	2	2	18025-2	WASHER, SPRG LOCK, REG M4	21	
-	1	1	1803292-1	DRAG	20	
-	1	1	2-1901696-7	STRIP GUIDE, REAR	19	
-	1	1	2-1901695-7	STRIP GUIDE, FRONT	18	
-	4	4	1-2079383-1	SCR, BHSC, RoHS (M6 X 12)	17	
-	1	1	7-240641-5	SPACER	16	
-	1	1	240644-1	PLATE, REAR SHEAR	11	
-	2	2	1-240645-2	SPACER, SHEAR PLATE	10	
-	1	1	240642-1	PLATE, FRONT SHEAR	9	
-	1	2	1	1333222-8	ANVIL, COMBINATION	8
-	1	1	2-240651-1	BLADE, SLUG	7	
-	1	1	1-240641-0	SPACER	5	
-	1	1	238011-2	BLOCK, CRIMPER SPACER	4	
-	1	2	1	2119582-3	CRIMPER, INSULATION F PREMIUM	3
-	1	1	1-455888-0	SPACER, CRIMPER	2	
-	1	2	1	456411-9	CRIMPER, WIRE PREMIUM	1
-	77	72	2	PART NO	DESCRIPTION	ITEM NO

ATLANTIC VERSION
Shown on sheets 1 of 4 & 2 of 4
(Pacific version shown on sheets 3 of 4 & 4 of 4)

DIMENSIONS:		TOLERANCES UNLESS OTHERWISE SPECIFIED:		MATERIAL:	
mm	0 PLC ±	1 PLC ±	2 PLC ±	3 PLC ±	4 PLC ±
	ANGLES	FINISH			
DWN L. ZHANG 10OCT2012		CHK L. ZHANG 10OCT2012		APVD S. XI 10OCT2012	
NAME		SIZE		CAGE CODE	
Ocean End Feed Applicator		A1		00779	
DRAWING NO		SCALE		SHEET	
2150296		1:1		1 of 4	
Customer Accessible Production Drawing				REV D	

LOC	DIST	REVISIONS			
P	LTN	DESCRIPTION	DATE	DWN	APVD
A	66	SEE SHEET 1	-	-	-

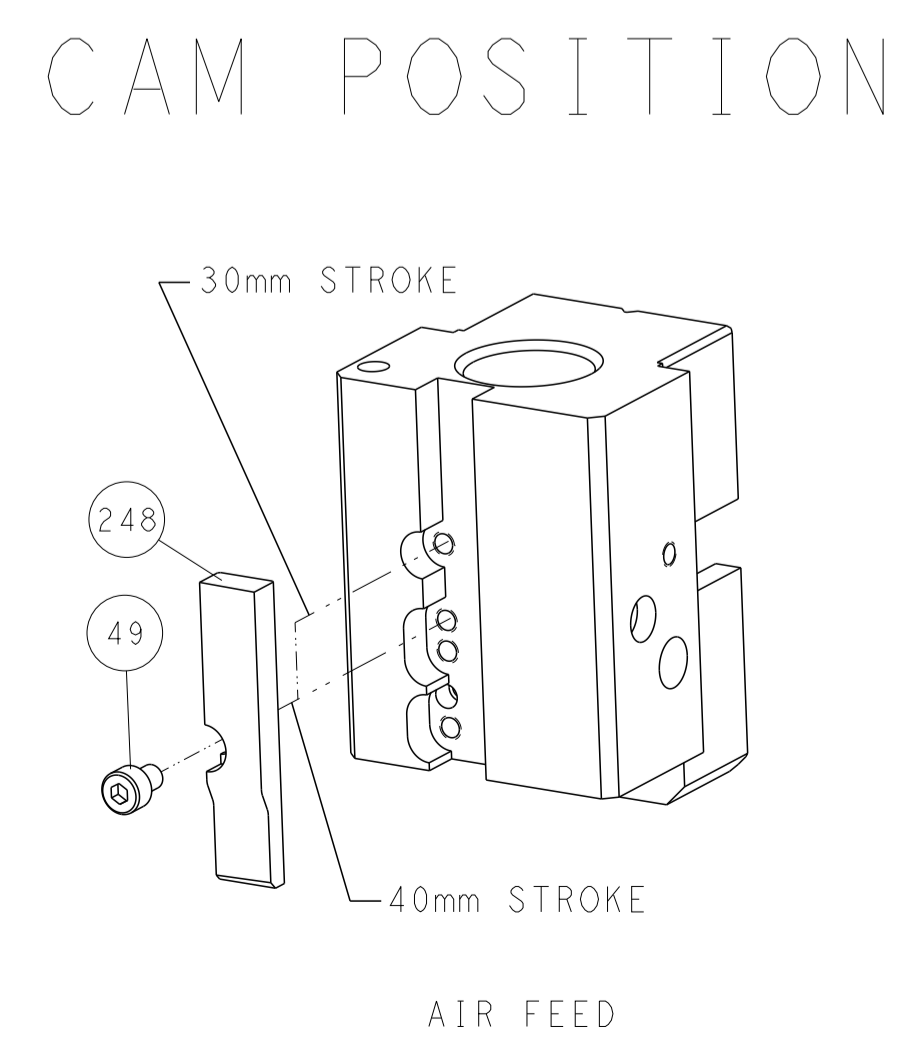
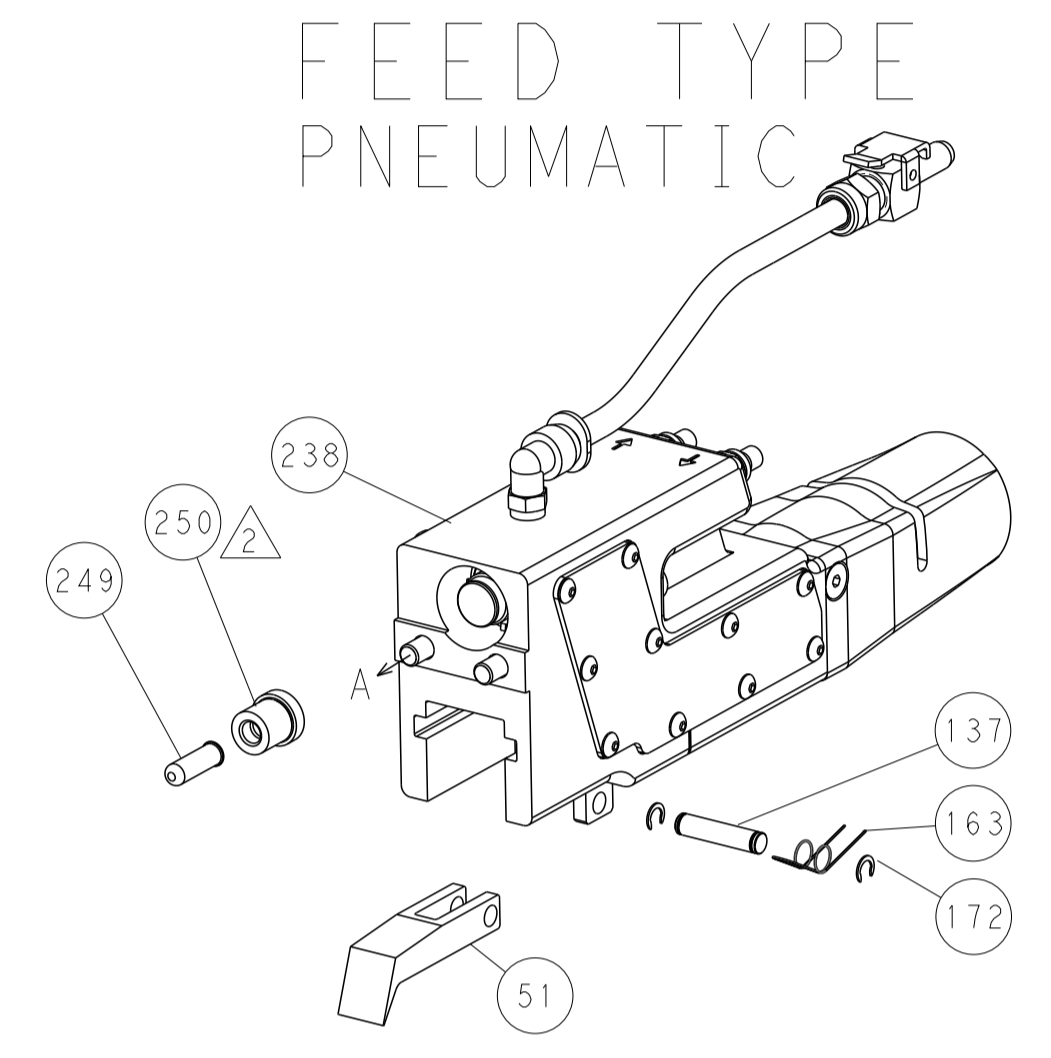
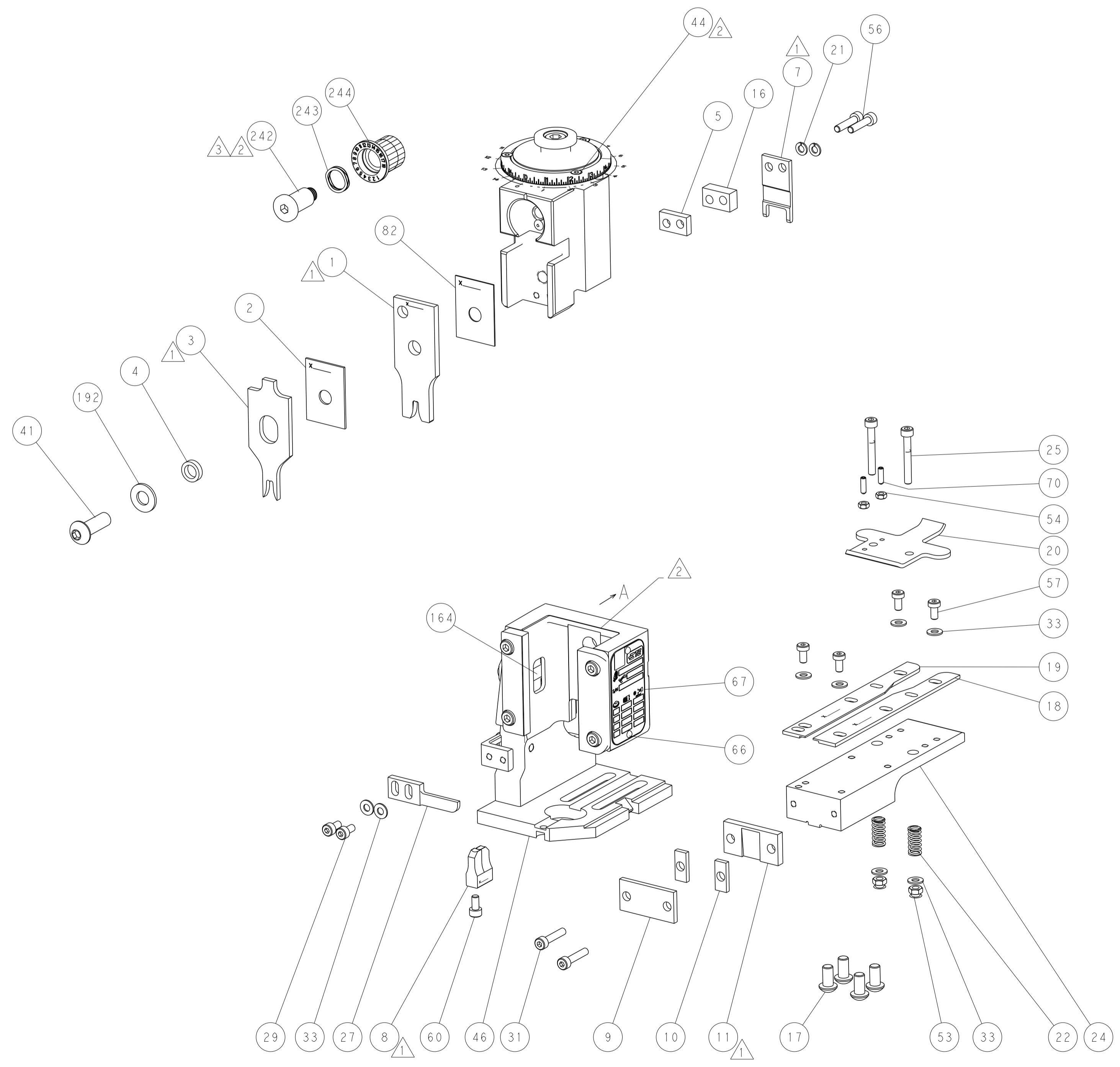
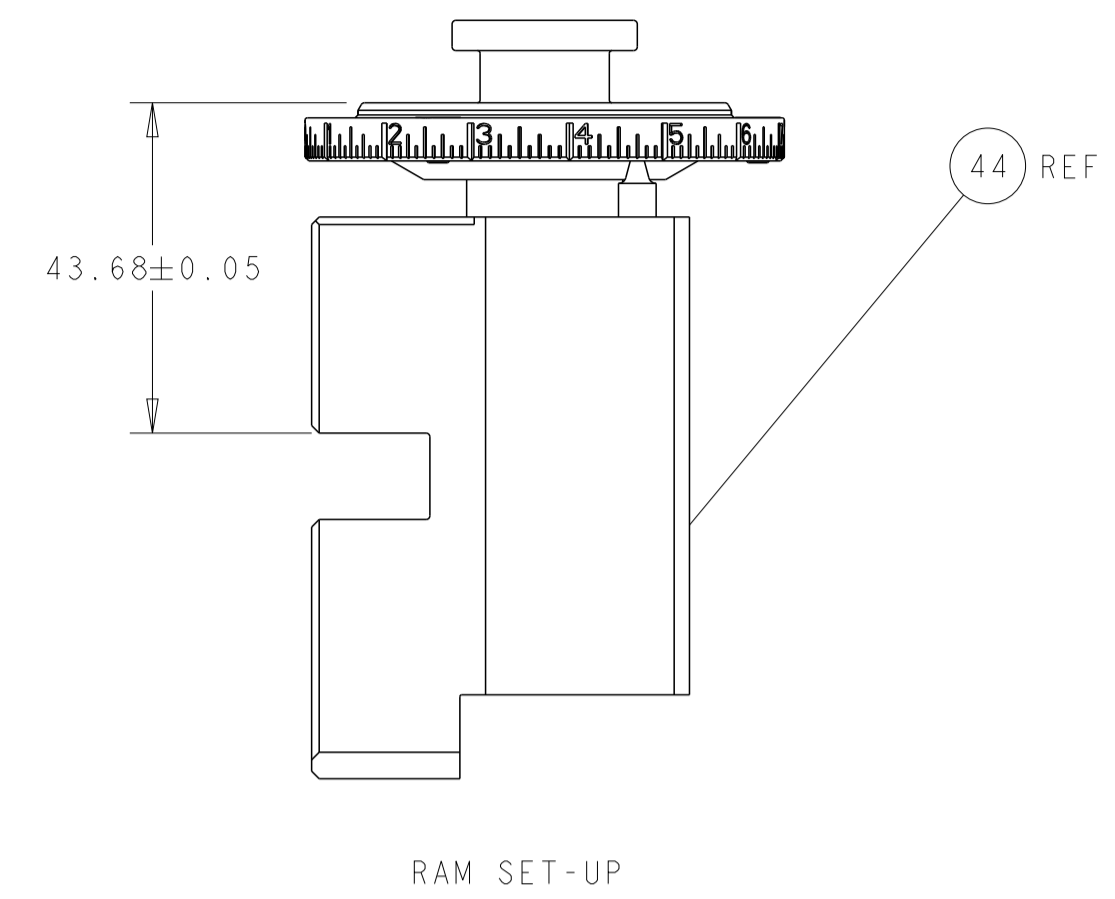

ATLANTIC VERSION
 Shown on sheets 1 of 4 & 2 of 4
 (Pacific version shown on sheets 3 of 4 & 4 of 4)

<small>THIS DRAWING IS UNPUBLISHED. RELEASED FOR PUBLICATION BY TYCO ELECTRONICS CORPORATION. ALL RIGHTS RESERVED.</small>		DWN L. ZHANG 10OCT2012 CHK L. ZHANG 10OCT2012 S. XI 10OCT2012 APVD S. XI 10OCT2012	TE Connectivity Harrisburg, PA 17105-3608
DIMENSIONS: mm TOLERANCES UNLESS OTHERWISE SPECIFIED: 0 PLC ± 1 PLC ± 2 PLC ± 3 PLC ± 4 PLC ± ANGLES ± MATERIAL: - FINISH: -		NAME: Ocean End Feed Applicator APPLICATION SPEC: - PRODUCT SPEC: - SIZE: A1 CAGE CODE: 00779 DRAWING NO: C=2150296 WEIGHT: - SCALE: 1:1 SHEET: 2 of 4 REV: D	RESTRICTED TO: -
Customer Accessible Production Drawing			

PART NUMBER	REVISION	DESCRIPTION	FEED TYPE
2-2150296-2	D	FINE CRIMP HEIGHT ADJUST	PNEUMATIC
7-2150296-7	A	CRIMP TOOLING KIT	-

PACIFIC VERSION TERMINATOR
 INTERFACE ADAPTER

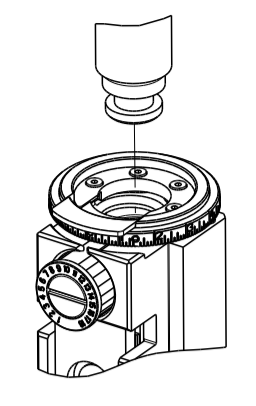

APPLICATOR DATA		
CRIMP	SIZE	TYPE
WIRE	3.56 mm [.140]	F
INSUL	4.57 mm [.180]	F
APPLICATOR INSTRUCTIONS 408-35043		

TERMINAL DATA: TE TERMINAL		TE CRIMP SPECIFICATION	
TERMINAL NAME: RINGTONGUE WITH INS SUPPORT			
WIRE STRIP LENGTH 4.80-5.60 mm [.189-.220 IN]		INSULATION DIAMETER RANGE ∅2.54-3.81 mm [.100-.150 IN]	
TERMINAL APPLICATION SPECIFICATION	114-3118	-	-
TERMINALS APPLIED			
TE TERMINAL	TE TERMINAL	TE TERMINAL	TE TERMINAL
160789-2	160789-3	160789-5	

WIRE SIZE	CRIMP HEIGHT mm [INCH]	CRIMP HEIGHT REFERENCE SETTING
2.50mm2	2.29 +/- 0.05 [.090 +/- .002]	4.4
2.00mm2	2.18 +/- 0.05 [.086 +/- .002]	5.7
1.50mm2	2.06 +/- 0.05 [.081 +/- .002]	7.0
1.00mm2	1.96 +/- 0.05 [.077 +/- .002]	8.0



- RECOMMENDED SPARE PARTS
- REFER TO SUPPLIED INSTRUCTION SHEET FOR CLEANING, LUBRICATION AND STORAGE OF APPLICATOR.
- APPLY PART NUMBER 2-23419-6 LOCTITE TO THREADS OF ITEM 242.
- CRIMP HEIGHT REFERENCE SETTING WAS THE SETTING USED WHEN THE APPLICATOR WAS QUALIFIED AT THE FACTORY. ADJUSTMENT MAY BE NECESSARY WHEN RUNNING APPLICATOR IN THE FIELD.
- UNLESS SPECIFIED OTHERWISE TORQUE VALUES SHALL BE USED PER DOCUMENT, 101-35000.
- TERMINAL PITCH NOT COMPATIBLE WITH MECHANICAL FEED.

***WARNING**
 ON INSTALLATION, SET WIRE DISC TO CRIMP HEIGHT REFERENCE SETTING FOR LARGEST WIRE SIZE. CRIMP HEIGHT REFERENCE SETTINGS GREATER THAN THE VALUE SHOWN MAY CAUSE DAMAGE TO THE CRIMP TOOLING. REFER TO THE INSTRUCTION SHEET FOR PROPER SETUP AND ADJUSTMENTS.

LOC	DIST	REVISIONS					
A	66	P	LTN	DESCRIPTION	DATE	DWN	APVD
-	-	-	-	SEE SHEET 1	-	-	-

-	1	2119640-1	PUSH ROD, AIR FEED	250	
-	1	1803259-1	BUSHING, FLANGED	249	
-	1	2119082-9	CAM, SNAIL, INSULATION ADJUSTMENT	244	
-	1	2079764-1	WASHER, WAVE SPRING, CREST-TO-CREST	243	
3	-	1	2119083-1	RETAINER, INSULATION DIAL	242
-	1	2063440-2	AIR FEED MODULE	238	
-	1	1-18028-0	WASHER, FLAT, REG M8	192	
-	4	2079383-9	SCR, BHSC, RoHS (M6 X 20)	186	
-	2	21045-3	RING, RETAIN, EXTERN, 3/16 CRESCENT	172	
-	REF	994970-2	COUNTER, MAGNETIC	164	
-	1	240638-1	SPRING, FEED FINGER	163	
-	1	2119641-2	FEED CAM, AIR FEED	152	
-	1	2168083-8	SCR, SKT HD CAP, RoHS, M4 X 16	144	
-	1	2119655-6	APPLICATOR BASIC ASSEMBLY, EF	141	
-	1	1803518-1	RAM ASSEMBLY, EF PACIFIC	140	
-	1	3-23627-7	PIN, RETAIN, GRVD, 3/16 X .854	137	
-	1	455888-5	SPACER, CRIMPER	82	
-	1	1803607-2	DOCUMENTATION PACKAGE	71	
-	2	2-18032-2	SCR, SET, FLT PNT, M3 X 10.0	70	
-	1	2119740-1	TAG, IDENTIFICATION	67	
-	2	2168078-1	SCREW, DRIVE, RH, RoHS, 2 x .188	66	
-	4	2168400-4	SHCS, LOW HEAD, RoHS, M4 X 8	57	
-	2	2-2168083-6	SCR, SKT HD CAP, RoHS, M4 X 18	56	
-	2	5018030-1	NUT, HEX, REG, RoHS, M3	54	
-	2	986965-8	NUT, LOCK, HEX, TORQUE (M4)	53	
-	1	2119792-2	PAWL, EF, AIR	51	
-	1	18023-9	SCR, SKT HD CAP M4 X 6.0	49	
-	1	1803602-1	SCR, BHSC, RoHS (M8 X 25)	41	
-	8	1-18028-2	WASHER, FLAT, REG M4	33	
-	2	2168083-9	SCR, SKT HD CAP, RoHS, M4 X 20	31	
-	2	2168083-2	SCR, SKT HD CAP, RoHS, M4 X 8.0	29	
-	1	240639-1	STRIPPER (MACHINING)	27	
-	2	1-2168083-5	SCR, SKT HD CAP, RoHS, M4 X 30	25	
-	1	1752371-1	PLATE, STRIP GUIDE	24	
-	2	3-22281-8	SPRING, COMPRESSION	22	
-	2	18025-2	WASHER, SPRG LOCK, REG M4	21	
-	1	1803292-1	DRAG	20	
-	1	2-1901696-7	STRIP GUIDE, REAR	19	
-	1	2-1901695-7	STRIP GUIDE, FRONT	18	
-	1	7-240641-5	SPACER	16	
1	-	1	240644-1	PLATE, REAR SHEAR	11
1	-	2	1-240645-2	SPACER, SHEAR PLATE	10
1	-	1	240642-1	PLATE, FRONT SHEAR	9
1	1	1	1333222-8	ANVIL, COMBINATION	8
1	-	1	2-240651-1	BLADE, SLUG	7
-	1	1	1-240641-0	SPACER	5
-	1	1	238011-2	BLOCK, CRIMPER SPACER	4
1	1	1	2119582-3	CRIMPER, INSULATION F PREMIUM	3
-	1	1	1-455888-0	SPACER, CRIMPER	2
1	1	1	456411-9	CRIMPER, WIRE PREMIUM	1

PACIFIC VERSION
 Shown on sheets 3 of 4 & 4 of 4
 (Atlantic version shown on sheets 1 of 4 & 2 of 4)

DIMENSIONS: mm		TOLERANCES UNLESS OTHERWISE SPECIFIED:		DWN L. ZHANG 10OCT2012		CHK L. ZHANG 10OCT2012		APVD S. XI 10OCT2012		NAME		SIZE		CAGE CODE		DRAWING NO		RESTRICTED TO	
0 PLC ±		1 PLC ±		2 PLC ±		3 PLC ±		4 PLC ±		APPLICATION SPEC		A1		00779		C=2150296		-	
MATERIAL		FINISH		WEIGHT		SCALE		SHEET		3 OF 4		REV		D					

Customer Accessible Production Drawing

LOC	DIST	REVISIONS			
P	LTN	DESCRIPTION	DATE	OWN	APVD
A	66	SEE SHEET 1			

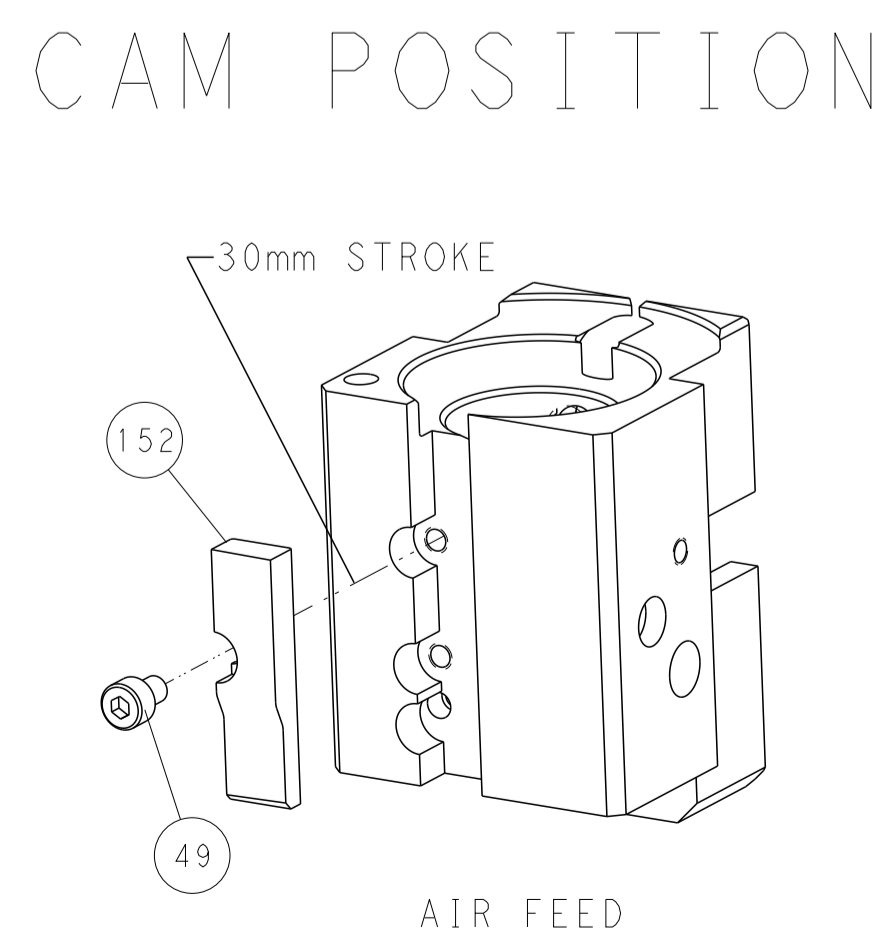
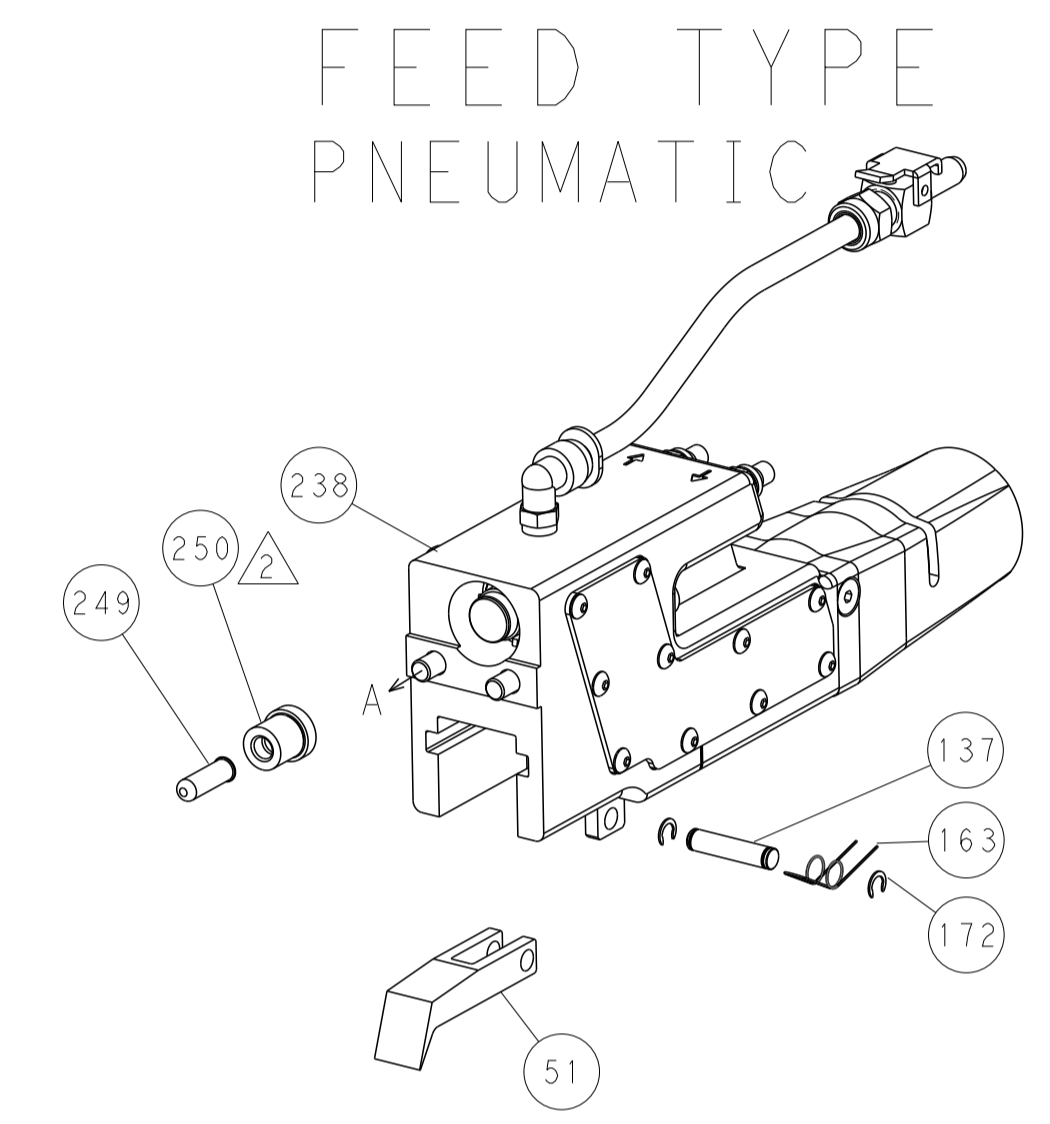
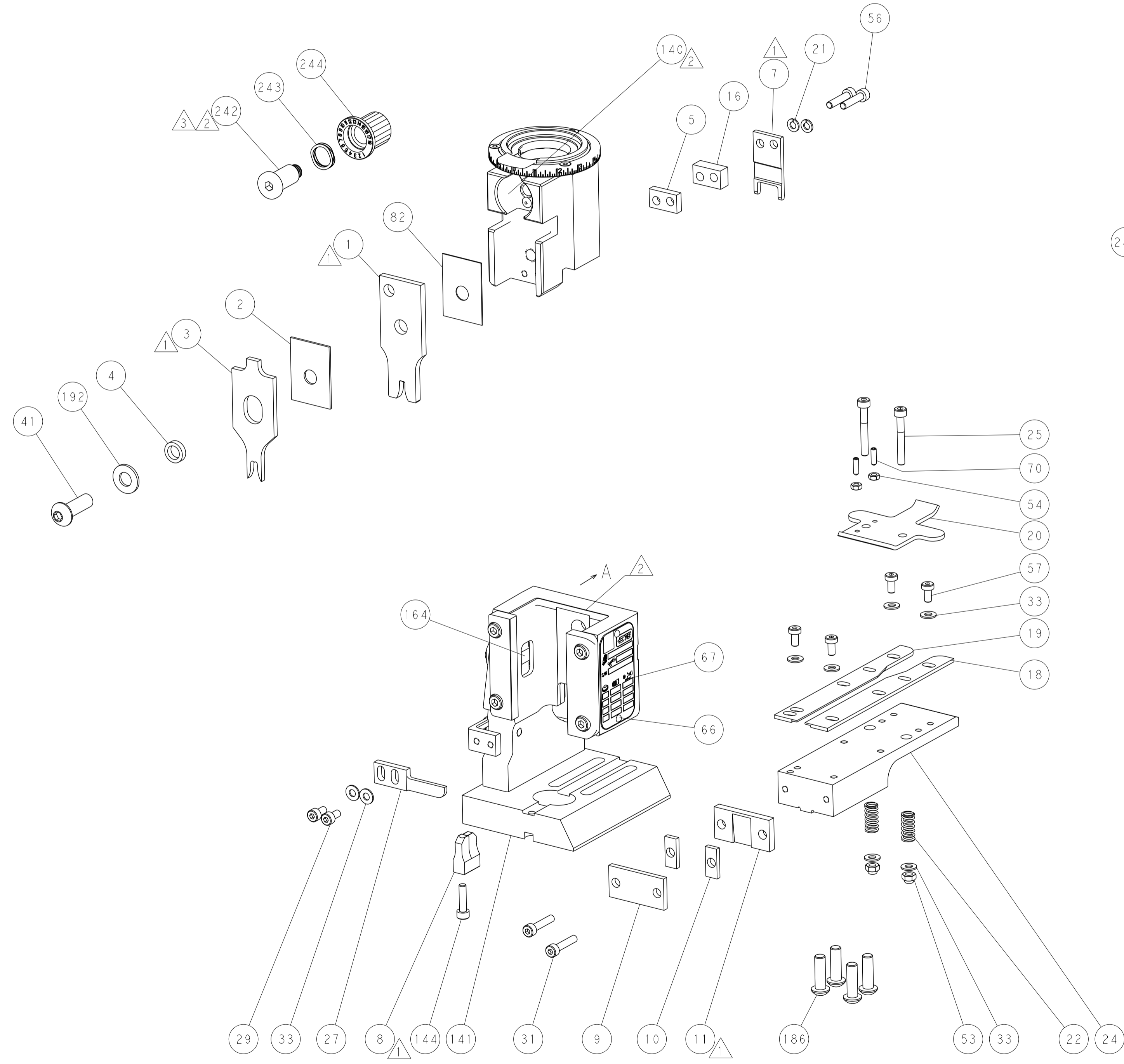
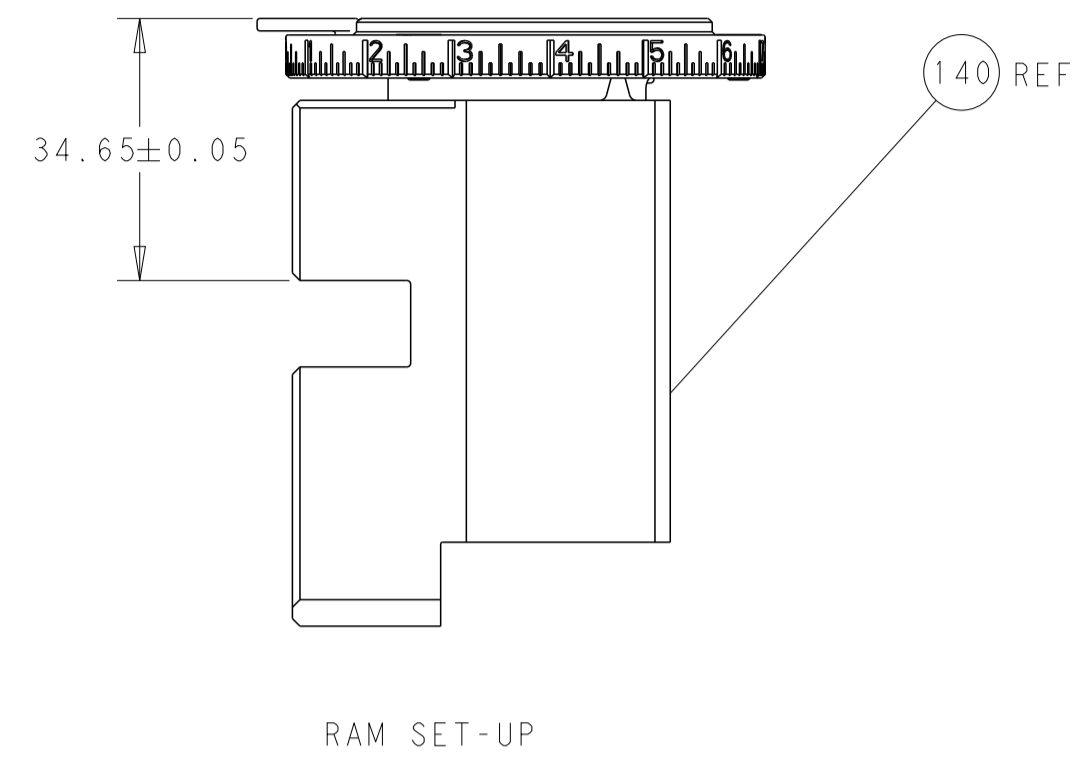

PACIFIC VERSION
 Shown on sheets 3 of 4 & 4 of 4
 (Atlantic version shown on sheets 1 of 4 & 2 of 4)

<small>THIS DRAWING IS UNPUBLISHED. RELEASED FOR PUBLICATION 20. COPYRIGHT 20 BY TYCO ELECTRONICS CORPORATION. ALL RIGHTS RESERVED.</small>		DWN L. ZHANG 10OCT2012 CHK L. ZHANG 10OCT2012 APVD S. XI 10OCT2012	TE Connectivity Harrisburg, PA 17105-3608
DIMENSIONS: mm TOLERANCES UNLESS OTHERWISE SPECIFIED: 0 PLC ± 1 PLC ± 2 PLC ± 3 PLC ± 4 PLC ± ANGLES ± FINISH ±		NAME Ocean End Feed Applicator SIZE CAGE CODE DRAWING NO. RESTRICTED TO A 00779 ©=2150296 -	
MATERIAL:		WEIGHT:	SCALE 1:1 SHEET 4 OF 4 REV D Customer Accessible Production Drawing