

3. USE THIS PRODUCT

3.1 Attach to measurement machine

MM206417 must be attached to machine at the two screw holes in probe flange (Figure 2).

Using guide pins is recommended. The guide pins should not be above probe flange (Figure 3).

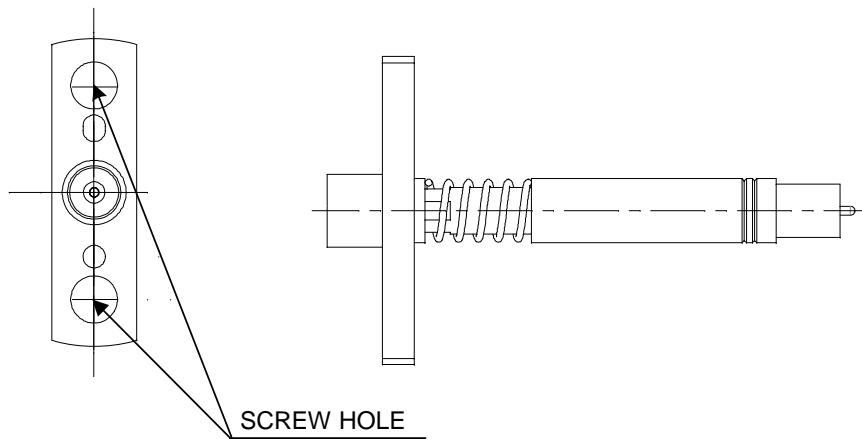

Figure 2. Screw hole

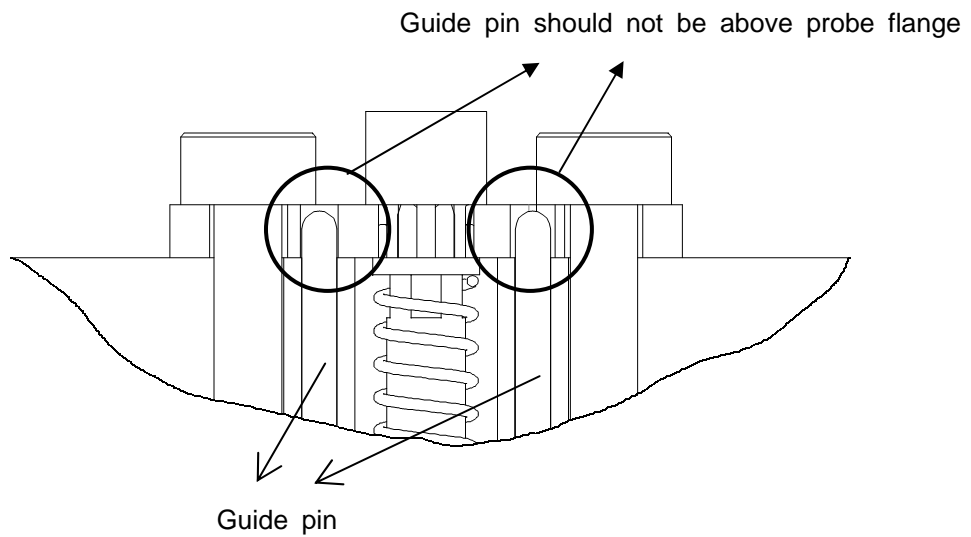

Figure 3. Positional relation between guide pin and probe flange

3.2 The tolerance of position against SWG type receptacle

3.2.1 MM206417 has a centering function by its design, +/-0.5mm is permitted against the hole center of SWG type receptacle.

Please avoid needless force to SMPM interface when MM206417 is disengaged from SWG type receptacle and comes back to its original position.

To avoid the needless force, please use extension cable assembly, MXHQ87SM3000/MXHR87SN3000 (Figure 4/Figure 5).

Centering function +/-0.5mm may not be permitted against the hole center of SWG type receptacle, when MM206417 is affected by the needless force.

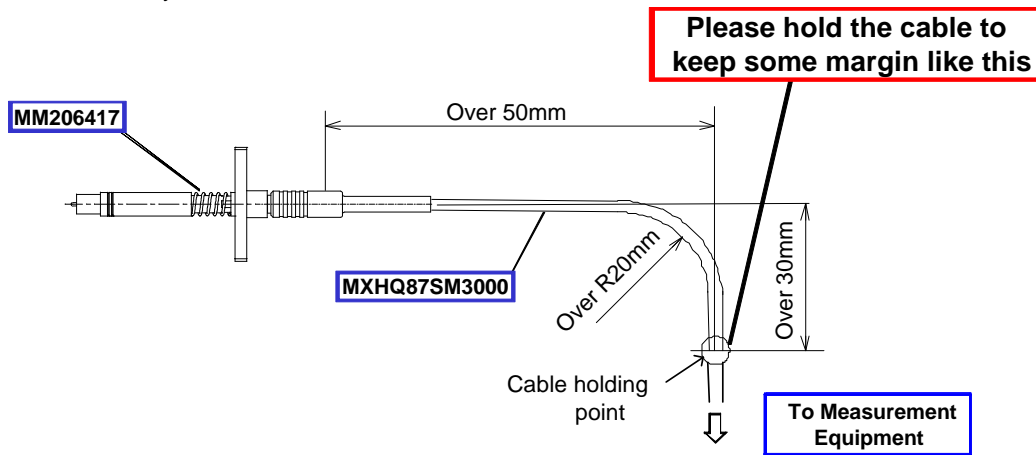

Figure 4. Instruction of MXHQ87SM3000

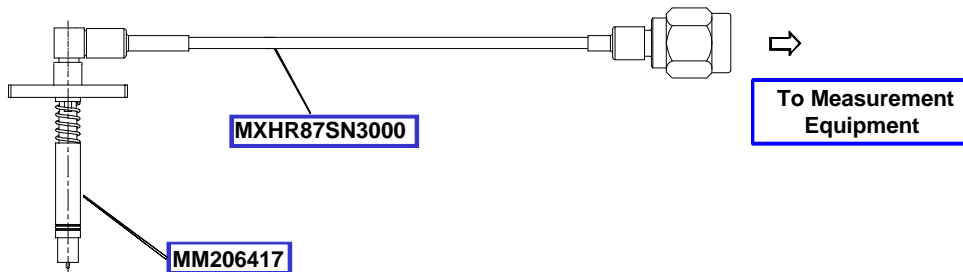

Figure 5. Instruction of MXHR87SN3000

Please use M19500 for un-mating MM206417 with MXHQ87SM3000/MXHR87SN3000 (Figure 6).

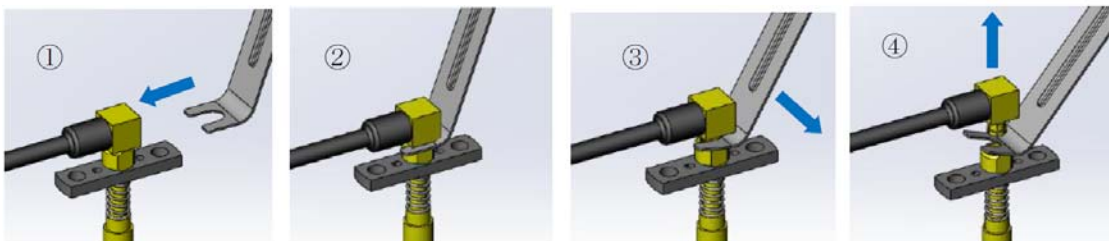

Figure 6. SMPM interface un-mating jig: M19500

3.2.2 To get 10dB or higher isolation (up to 11GHz), the engagement strokes from the flange to the tip of probe is 18.5mm to 19.5mm (Figure 7).

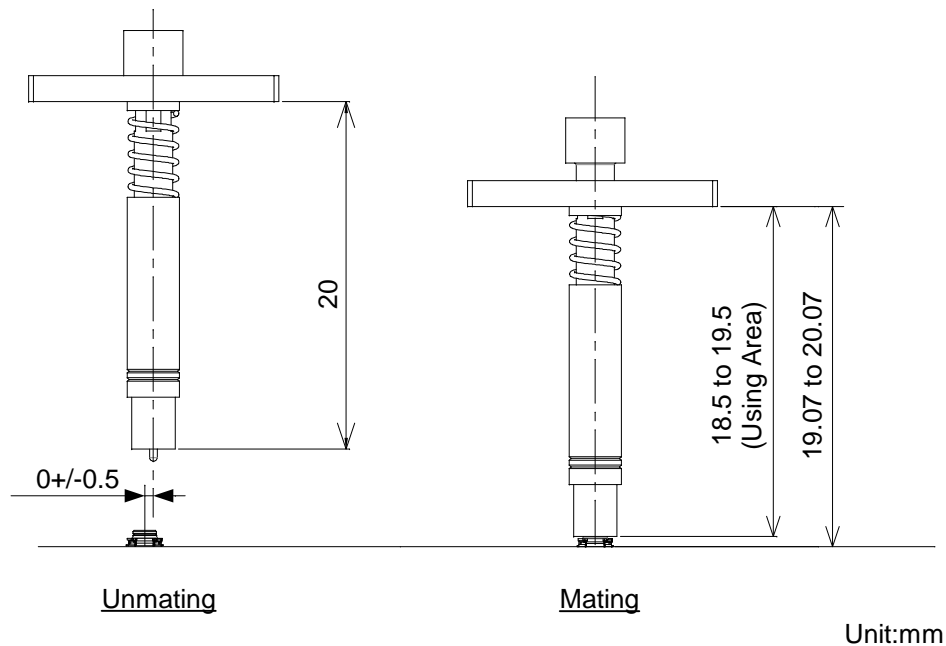

Figure 7. Acceptable Engagement range to SWG type receptacle

3.3 The slant angle tolerance of probe against SWG type Receptacle (Figure 8)
 To have a stable measurement, slant angle of MM206417 must be within +/-2degree.

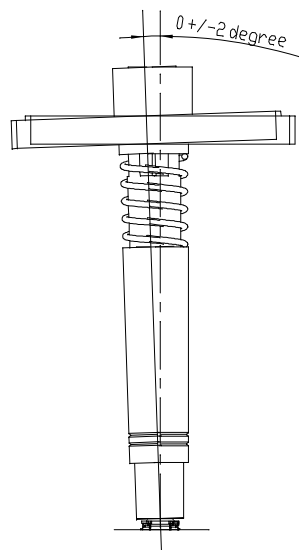

Figure 8. Probe Shape Operation Manual for Auto Measurement probe (MM206417)