

## Asynchronous Boost Controller

Halogen  
Free

### General Description

The FP5139 is a boost topology switching regulator control IC for battery-powered applications. The FP5139 includes a totem-pole single output stage for driving NPN transistor or N-MOS, high precision reference voltage(0.5V) to compare output voltage with feedback amplifier, an internal duty time control for controlling the minimum duty cycle, programmable soft start with short circuit protection function and logic level control for operating mode or standby mode.

### Features

- Wide Supply Voltage Operating Range: 1.8 to 15V
- Precision Reference Voltage: 0.5V  $\pm$ 2%
- Low Current Consumption: 5.5mA in Operation Mode
- Low Current Consumption: 1 $\mu$ A in Standby Mode
- High Oscillator Frequency: 1MHz max.
- Totem-Pole Output with Adjustable ON / OFF Current (for NPN Transistors or n-Channel MOSFET)
- Logic Level Control Stand-by Mode Function
- Programmable Soft Start Function (SS)
- Short Circuit Protection Function (SCP)
- Package: TSSOP-8L

### Applications

- Digital Camera
- PDA
- Portable Equipment

**Function Block Diagram**

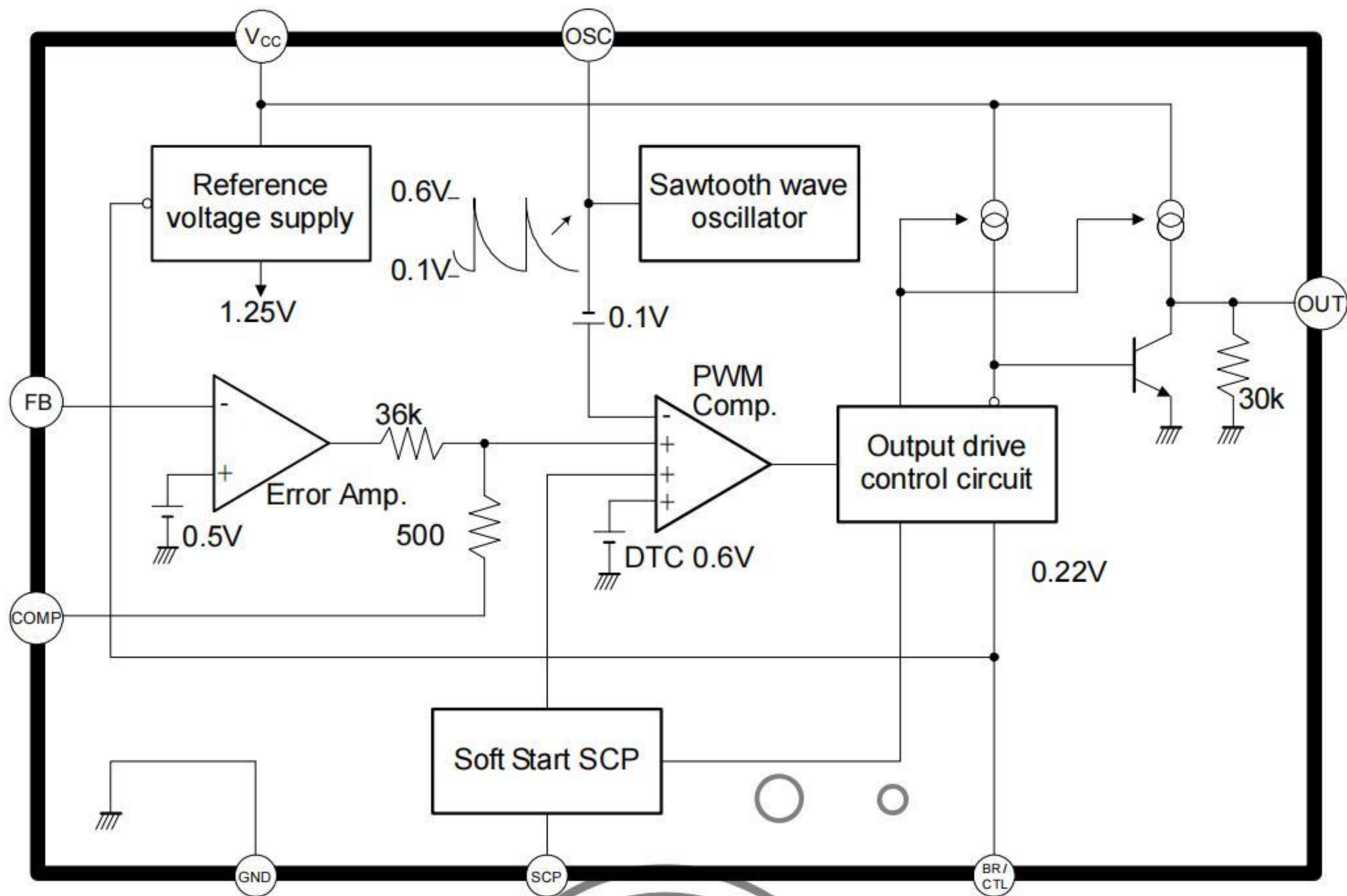

一级代理: 李生 13691661579

This datasheet contains new product information. Feeling Technology reserves the rights to modify the product specification without notice. No liability is assumed as a result of the use of this product. No rights under any patent accompany the sales of the product.

## Pin Descriptions

### TSSOP-8L



Name	No.	I / O	Description
FB	1	I	Error Amplifier Inverting Input
SCP	2	I	Soft Start and SCP Function Connect a Capacitor to this pin
V <sub>CC</sub>	3	P	IC power supply
BR / CTL	4	I	Output Current Setting and Control
OUT	5	O	Totem-Pole Output
GND	6	P	IC Ground
OSC	7	I	Oscillator Output: Connect Capacitor and Resistor to this pin for Frequency Adjustment
COMP	8	O	Error Amplifier Compensation Output

## Marking Information

### TSSOP-8L

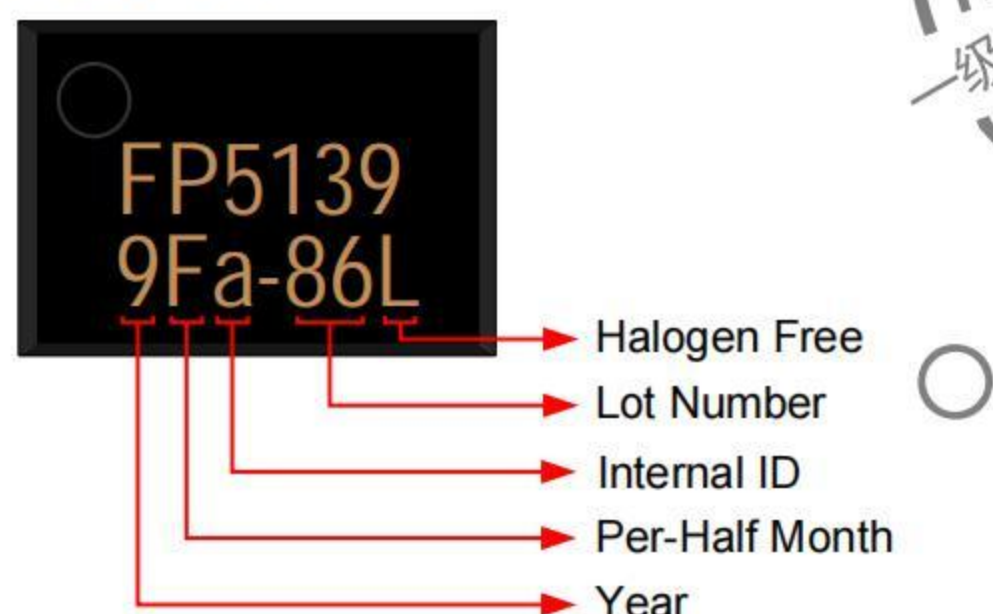

**Halogen Free:** Halogen free product indicator

**Lot Number:** Wafer lot number's last two digits

For Example: 132386TB → 86

**Internal ID:** Internal Identification Code

**Per-Half Month:** Production period indicated in half month time unit

For Example: January → A (Front Half Month), B (Last Half Month)

February → C (Front Half Month), D (Last Half Month)

**Year:** Production year's last digit

### Ordering Information

Part Number	Operating Temperature	Package	MOQ	Description
FP5139BWR-LF	-10°C ~ +85°C	TSSOP-8L	2500EA	Tape & Reel

### Absolute Maximum Ratings

Parameter	Symbol	Conditions	Min.	Typ.	Max.	Unit
Power Supply Voltage	$V_{IN}$				15	V
Output Source Current					-50	mA
Output Sink Current					50	mA
Allowable Power Dissipation		SOP-8L, $T_A \leq +25^\circ\text{C}$			570	mW
		MSOP-8L, $T_A \leq +25^\circ\text{C}$			400	mW
		TTSOP-8L, $T_A \leq +25^\circ\text{C}$			400	mW
Storage Temperature			-55		+125	°C
Lead Temperature		SOP-8L, (soldering, 10 sec)			+260	°C
		TSSOP-8L, (soldering, 10 sec)			+260	°C
		MSOP-8L, (soldering, 10 sec)			+260	°C

### Suggested IR Re-flow Soldering Curve

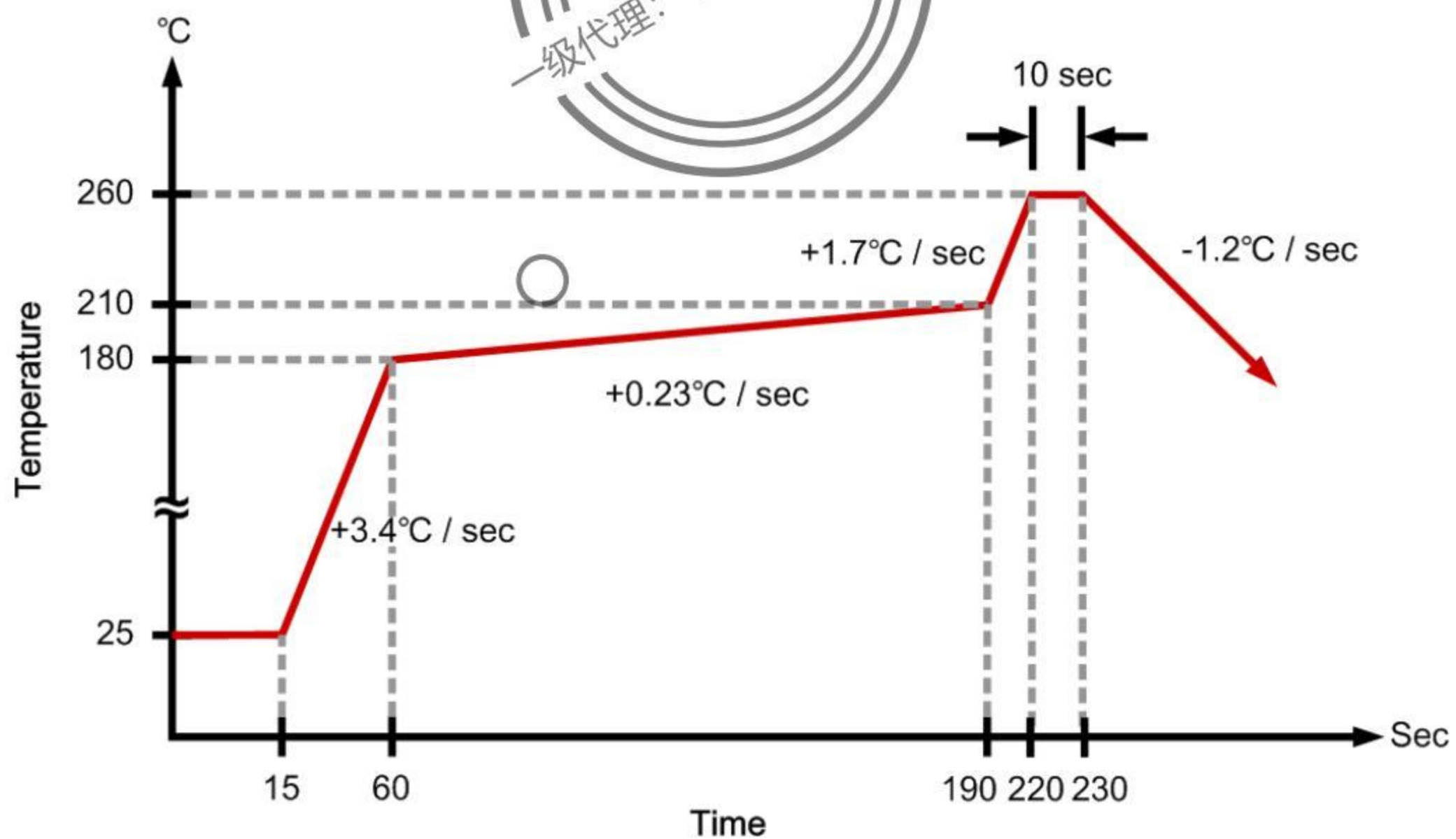

This datasheet contains new product information. Feeling Technology reserves the rights to modify the product specification without notice. No liability is assumed as a result of the use of this product. No rights under any patent accompany the sales of the product.

## Recommended Operating Conditions

Parameter	Symbol	Conditions	Min.	Typ.	Max.	Unit
Supply Voltage			1.8		15	V
Operating Temperature			-10		+85	°C

## DC Electrical Characteristics ( $V_{CC}=+2V$ , $T_A=25^\circ C$ , unless otherwise noted)

Parameter	Symbol	Test Conditions	Min.	Typ.	Max.	Unit
<b>Under Voltage Lock-Out Section (UVLO)</b>						
Low Threshold Voltage	$V_{LOW}$				0.9	V
Upper Threshold Voltage	$V_{UPPER}$		1.1	1.3	1.5	V
<b>Soft Start Section (SS)</b>						
Input Source Current	$I_{SS}$	$V_{SCP}=0V$	-1.5	-1.0	-0.7	$\mu A$
Soft Start Threshold Voltage	$V_{SST}$		0.8	0.9	1.0	V
<b>Short Circuit Protection Section (SCP)</b>						
Input Source Current	$I_{SCP}$	$V_{SCP}=0V$	-1.5	-1.0	-0.7	$\mu A$
SCP Threshold Voltage	$V_{SCP}$		0.7	0.8	0.9	V
<b>Oscillator Section</b>						
Oscillation Frequency	f	$R_T=3.0k\Omega$ , $C_T=270pF$	400	500	600	KHz
Frequency Change With Voltage	$\Delta f / \Delta V$	$V_{CC}=2V$ to $15V$		2	10	%
Frequency Change With Temperature	$\Delta f / \Delta T$	$T_A = 0^\circ C$ to $85^\circ C$		5		%
<b>Idle Period Adjustment Section</b>						
Maximum Duty Cycle	$T_{DUTY}$	$R_T=3.0k\Omega$ , $C_T=270pF$ , $V_{FB}=0.8V$		85		%
Maximum Duty Cycle Change With Temperature	$\Delta T_{DUTY} / \Delta T$	$T_A = -10^\circ C$ to $85^\circ C$		10		%
<b>Total Device Section</b>						
Standby Current	$I_{STANDBY}$	Pin 4 is open or $=V_{CC}$			1	$\mu A$
Average Current Consumption	$I_{AVE}$	$R_B=390\Omega$ , $V_{CC}=0\sim 15V$		5.0	10	mA
<b>Error Amplifier Section</b>						
Input Threshold Voltage	$V_{FB}$	$V_{COMP}=450mV$	490	500	510	mV
$V_T$ Change With Voltage	$\Delta V_{FB} / \Delta V$	$V_{CC}=2V$ to $15V$		5	20	mV
$V_T$ Change With Temperature	$\Delta V_{FB} / \Delta T$	$T_A = -10^\circ C$ to $85^\circ C$		1		%
Input Bias Current	$I_B$		-1.0	-0.2	1.0	$\mu A$
Voltage Gain	$A_V$			100		V / V
Frequency Bandwidth	BW	$A_V=0$ dB		6		MHz
Output Voltage Swing Positive	$V_{POS}$		0.78	0.87		V
Output Voltage Swing Negative	$V_{NEG}$			0.05	0.2	V
Output Source Current	$I_{SOURCE}$	$V_{COMP}=450$ mV		-40	-24	$\mu A$
Output Sink Current	$I_{SINK}$	$V_{COMP}=450$ mV	24	40		$\mu A$

This datasheet contains new product information. Feeling Technology reserves the rights to modify the product specification without notice. No liability is assumed as a result of the use of this product. No rights under any patent accompany the sales of the product.

Parameter	Symbol	Test Conditions	Min.	Typ.	Max.	Unit
<b>Output Section</b>						
Output High Voltage	$V_{OH1}$	$R_B=390\Omega, I_O=-15mA$	1.0	1.2		V
	$V_{OH2}$	$R_B=750\Omega, I_O=-10mA, V_{CC}=1.8V$	0.8	1.0		V
Output Saturation Voltage	$V_{OL1}$	$R_B=390\Omega, I_O=15mA$		0.1	0.2	V
	$V_{OL2}$	$R_B=750\Omega, I_O=10mA, V_{CC}=1.8V$		0.1	0.2	V
Output Source Current	$I_{OSOURCE}$	$R_B=390\Omega, V_O=0.9V$		-40	-20	mA
Output Sink Current	$I_{OSINK}$	$R_B=390\Omega, V_O=0.3V$	30	40	-	mA
Internal Pull-Down Resistor	$R_O$		20	30	40	k $\Omega$
<b>Output Current Setting / Control Section</b>						
Pin Voltage	$V_{BR}$	$R_B=390\Omega$	0.15	0.22	0.3	V
Input Off Condition	$I_{OFF}$		-20		0	$\mu A$
Input On Condition	$I_{ON}$				-45	$\mu A$
Pin Current Range	$I_{BR}$		-1.8		-0.1	mA



This datasheet contains new product information. Feeling Technology reserves the rights to modify the product specification without notice. No liability is assumed as a result of the use of this product. No rights under any patent accompany the sales of the product.

## Typical Operating Characteristics

( $V_{CC}=2V$ ,  $T_A=25^\circ C$ , unless otherwise noted)

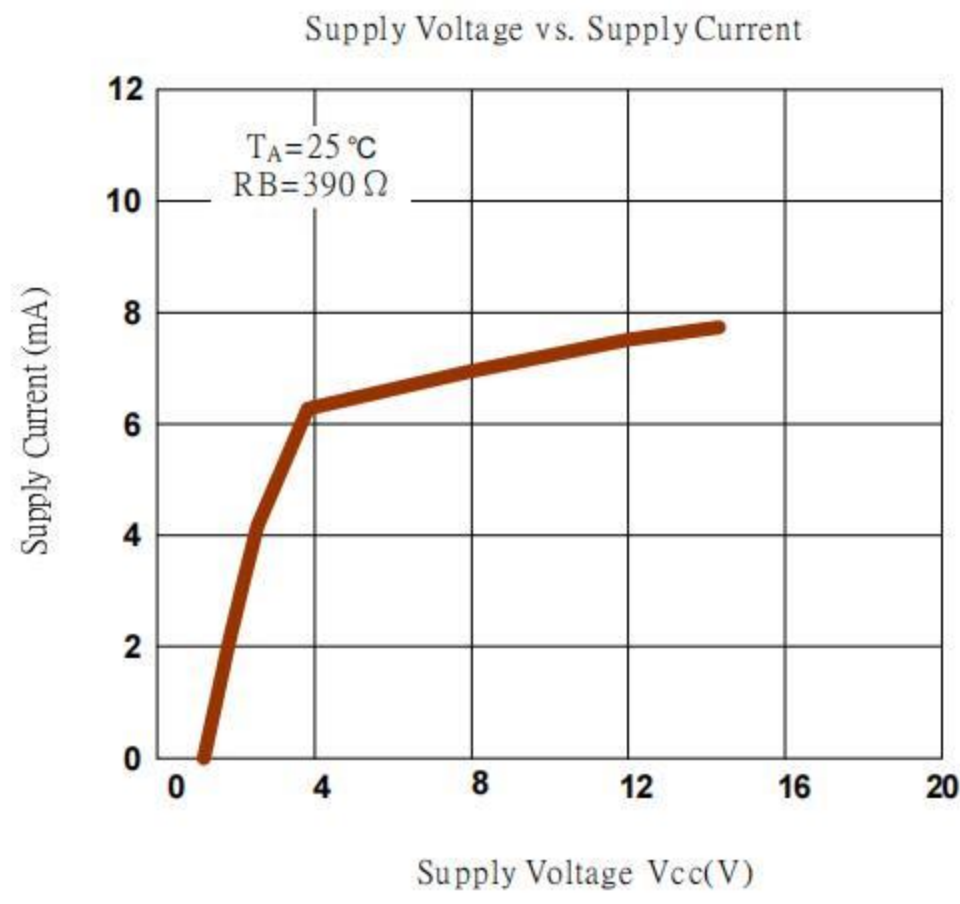

Figure 1

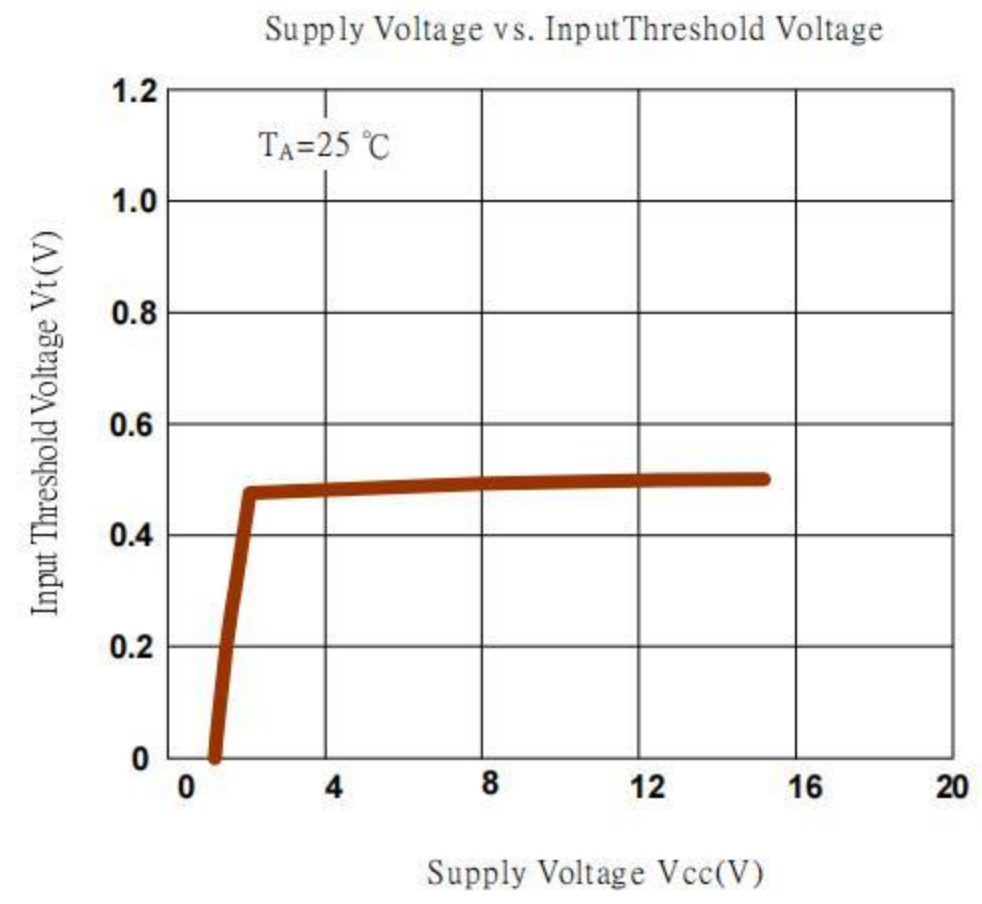

Figure 2

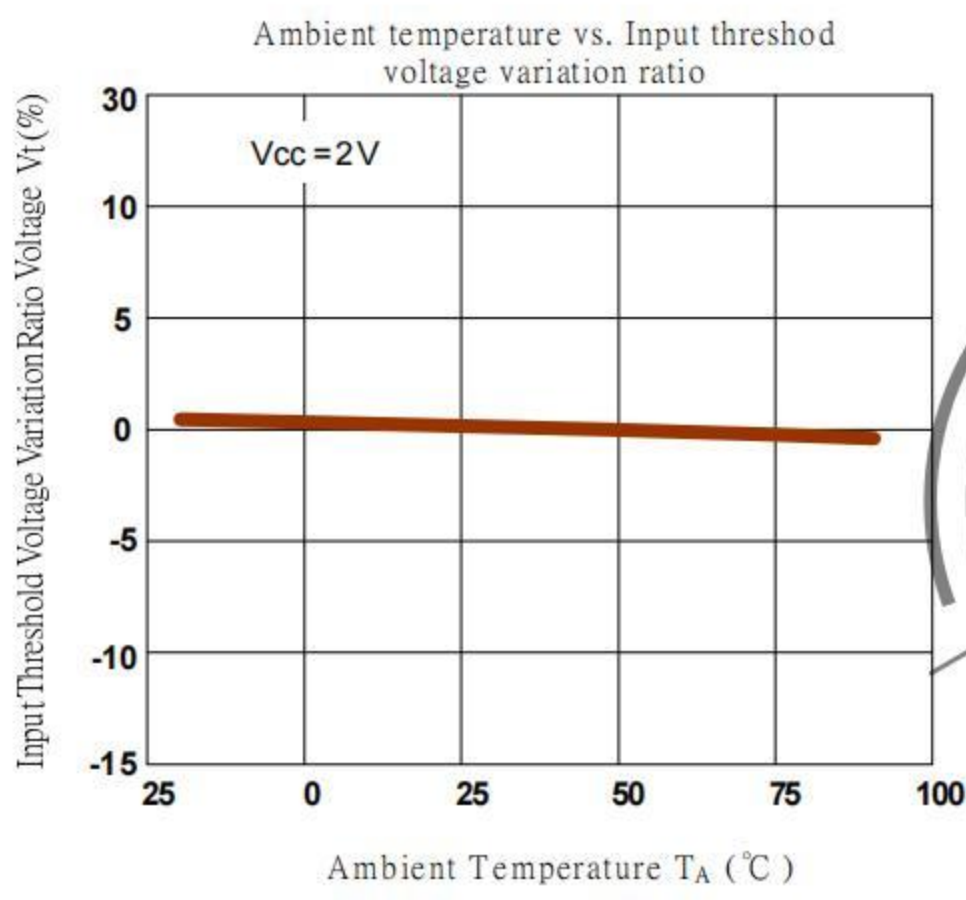

Figure 3

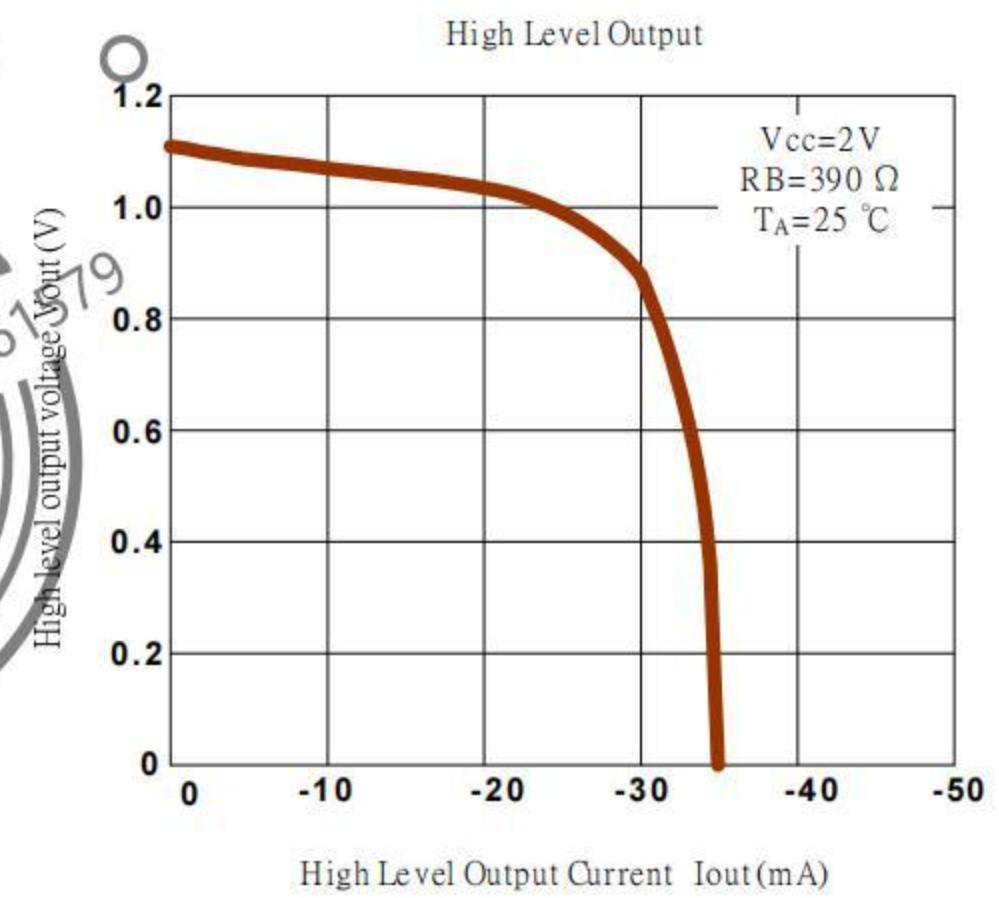

Figure 4

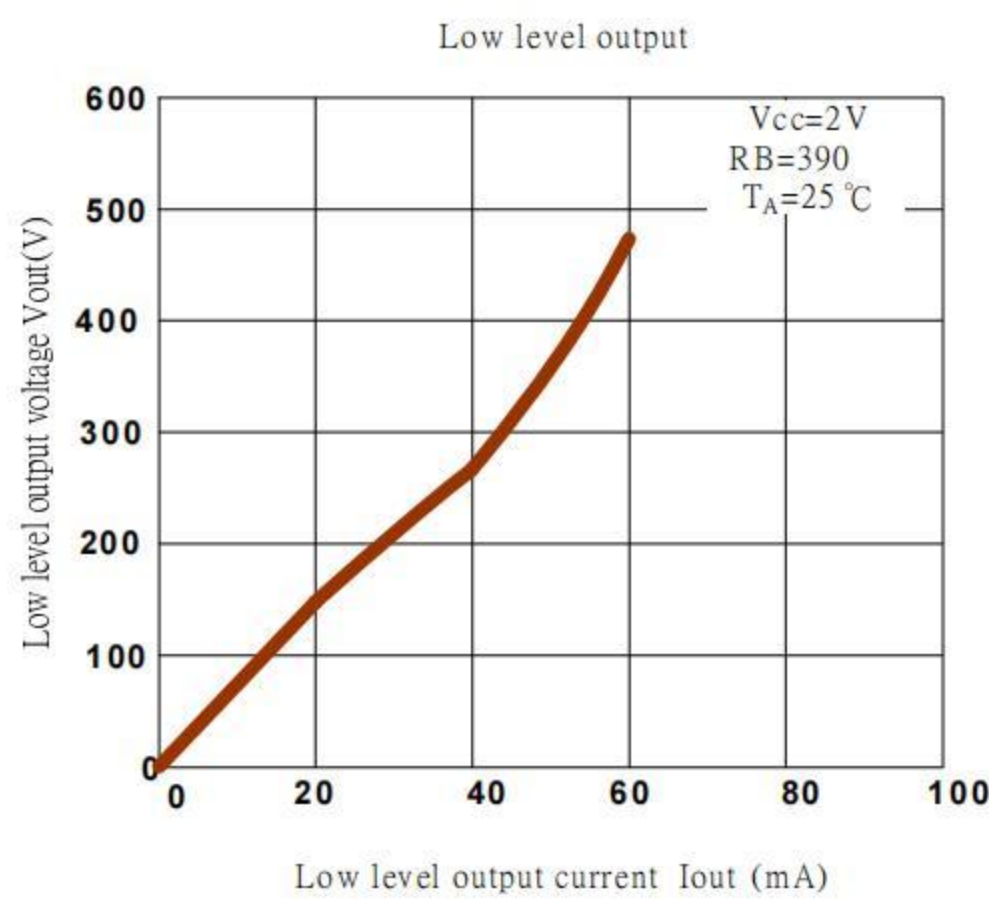

Figure 5

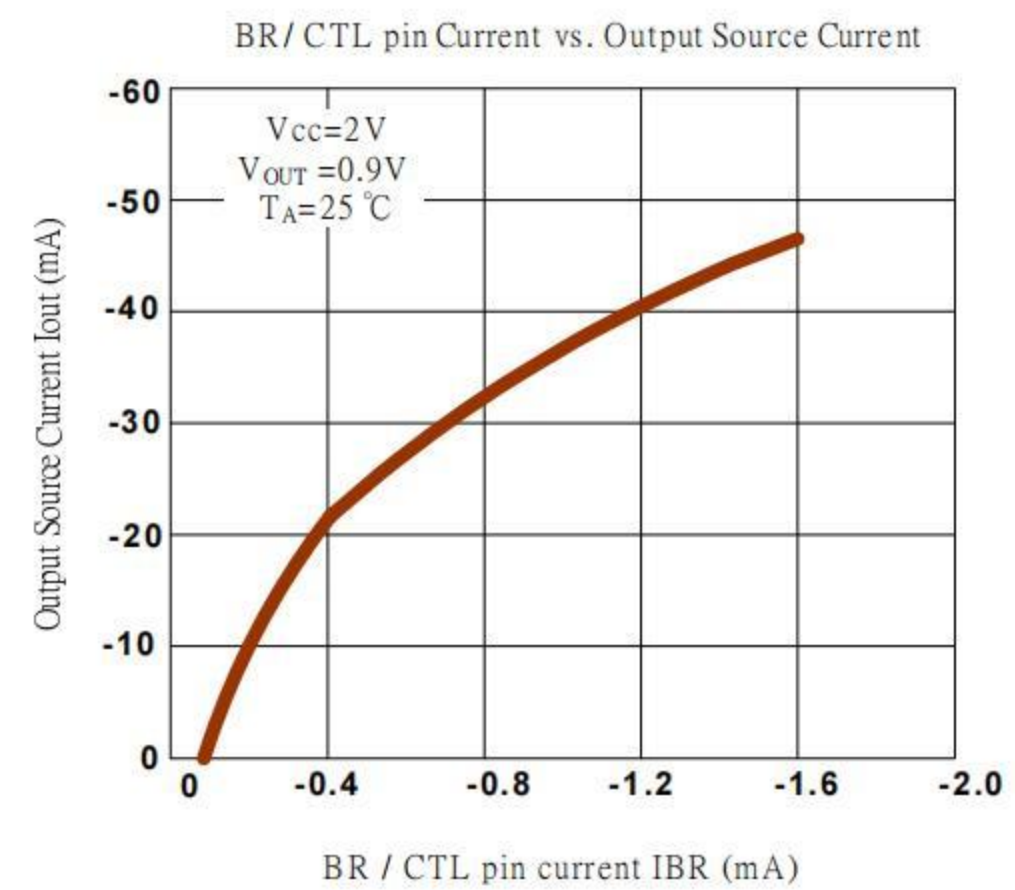

Figure 6

This datasheet contains new product information. Feeling Technology reserves the rights to modify the product specification without notice. No liability is assumed as a result of the use of this product. No rights under any patent accompany the sales of the product.

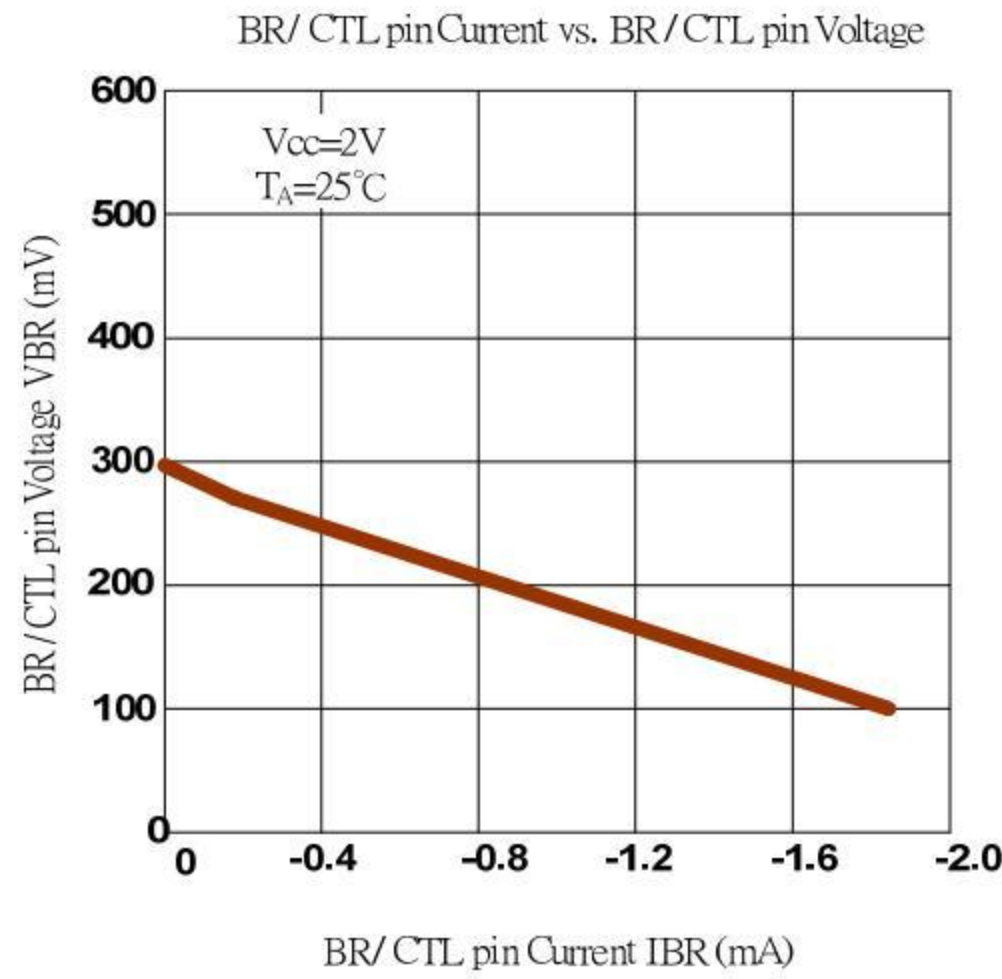

Figure 7

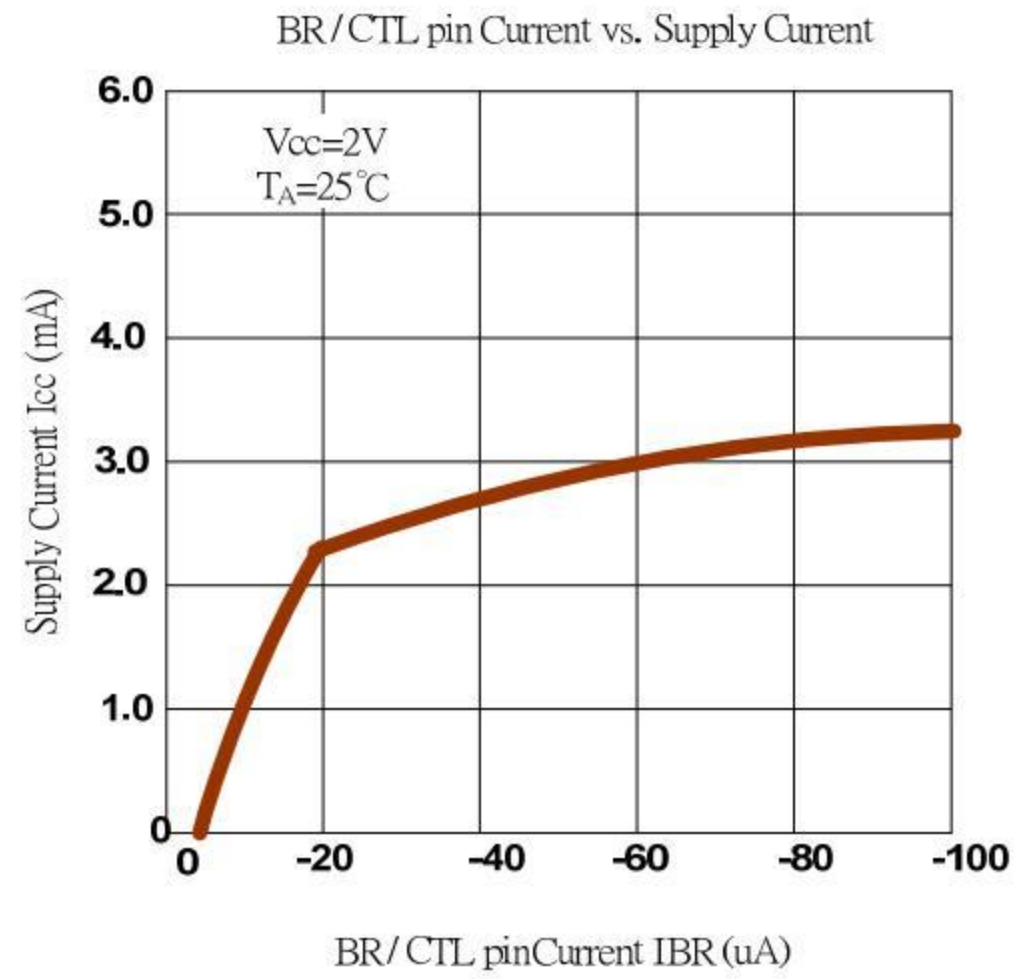

Figure 8

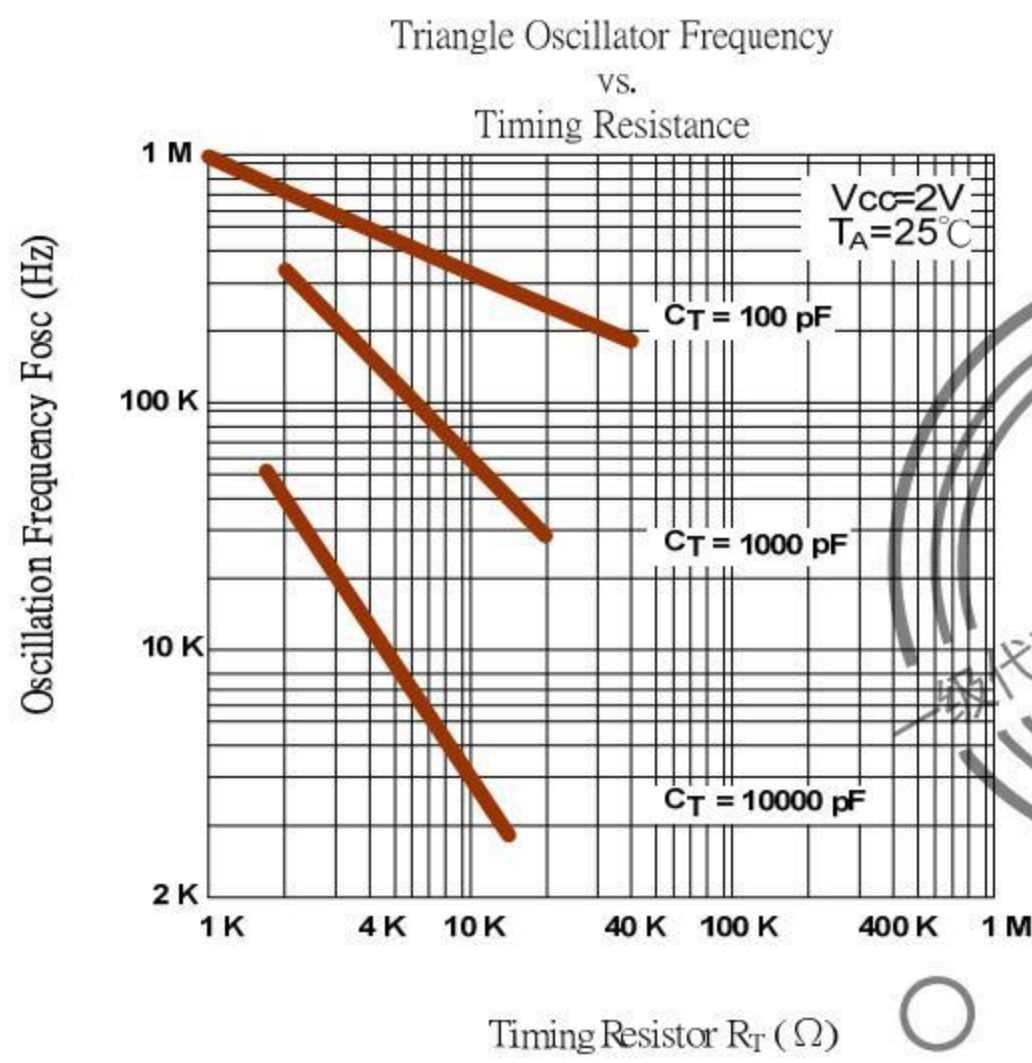

Figure 9

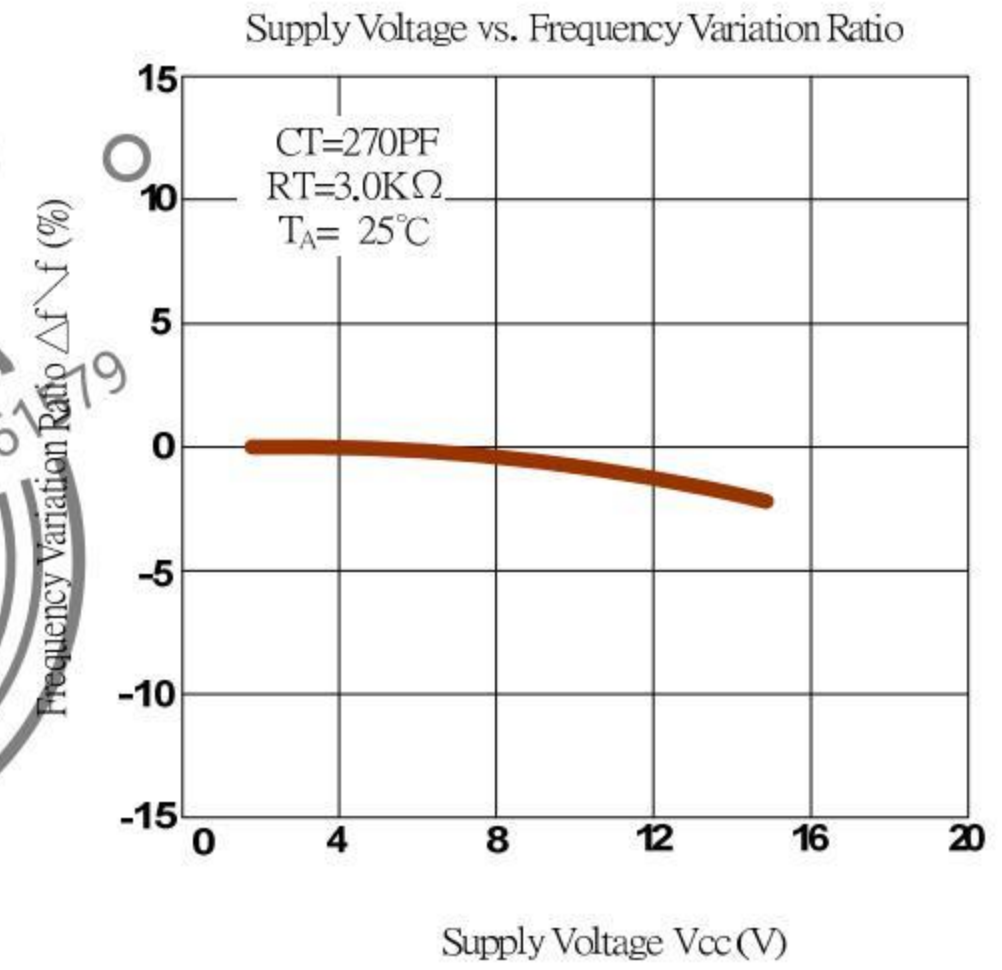

Figure 10

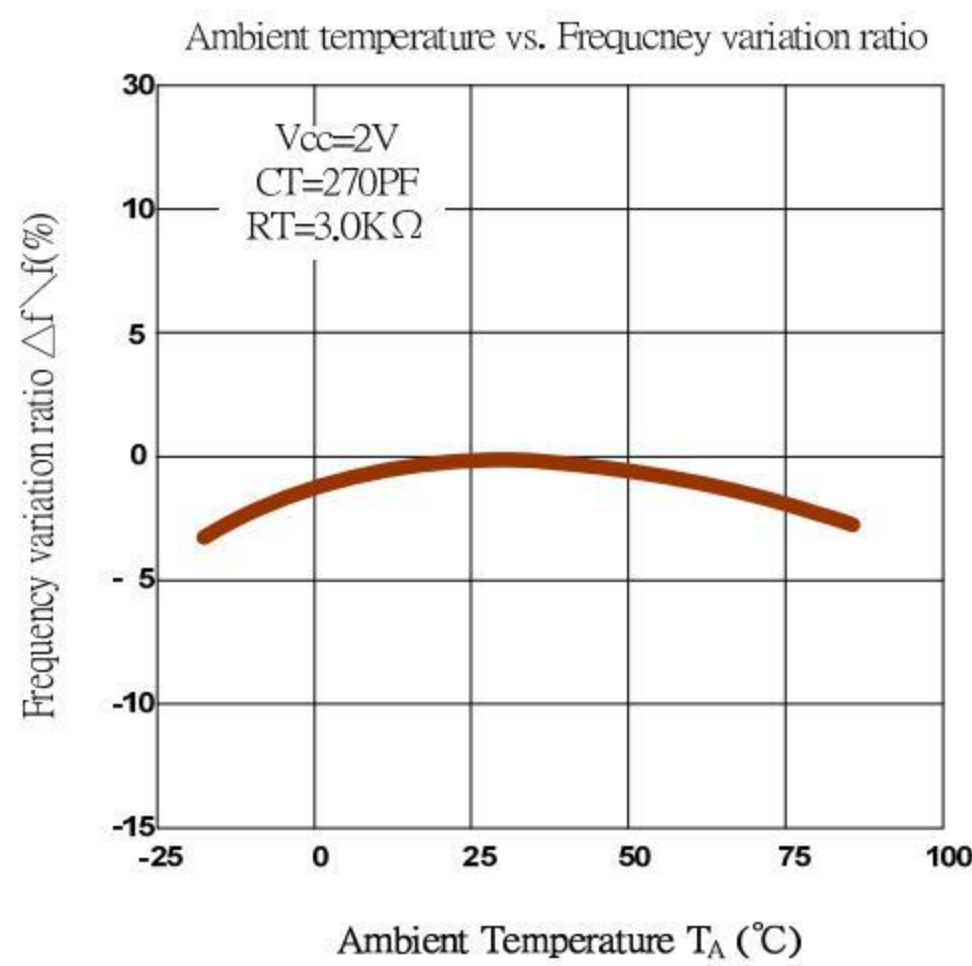

Figure 11

This datasheet contains new product information. Feeling Technology reserves the rights to modify the product specification without notice. No liability is assumed as a result of the use of this product. No rights under any patent accompany the sales of the product.



## Function Description

### Voltage Reference

A 1.25V regulator operating from  $V_{CC}$  is used to power the FP5139 internal circuitry. An internal resistive divider provides 0.5V reference for the error amplifier, Soft-start (0.9V typ.) and SCP (0.8V typ.) circuits.

### Error Amplifier

The error amplifier compares a sample of the DC-DC converter output voltage to the 0.5V reference and generates an error signal for the PWM comparator. Output voltage of DC-DC converter is setting with the resistor divider using the following equation (see figure12):

$$V_{OUT} = \left(1 + \frac{R1}{R2}\right) \times 0.5$$

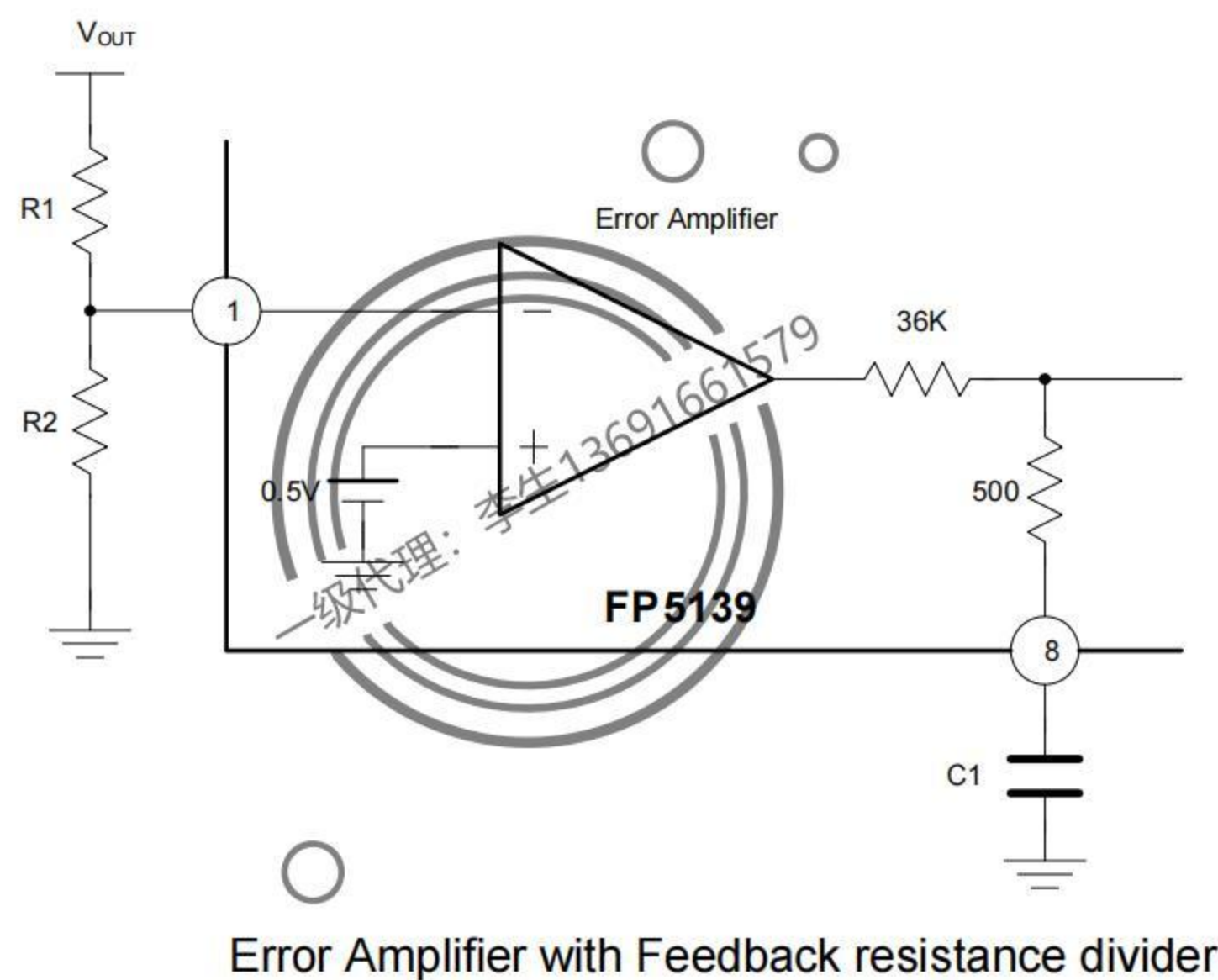

### Oscillator

The oscillator frequency can be set from 20KHz to 1MHz by connecting a resistor and a capacitor at OSC pin of FP5139 to ground. The oscillator frequency can be determined by using the graph shown in Figure 9.

The oscillator output is a sawtooth wave with a minimum value of approximately 0.1V and a maximum value of approximately 0.6V. The PWM comparator compares the oscillator voltage with error amplifier output voltage, internal maximum duty control voltage (0.6V typ.) and soft start setting voltage. When the sawtooth wave voltage is lower than all of above three-output voltage, the output of FP5139 is high (Turn on external NPN transistor or NMOS).

**Under Voltage Lockout (UVLO)**

The under voltage lockout circuits turn the output off whenever the supply voltage drops too low (approximately 0.9V at 25°C) for proper operation. A hysteresis voltage of 200mV eliminates false triggering on noise and chattering.

**Soft Start/ Short-circuit protection (SS / SCP)**

The soft start is functional after power on. The interval of soft start time is determined by a capacitor connected to SCP pin (pin 2). When soft start function finished, the internal soft start voltage is setting high, but external SCP pin is setting low in order to change to short circuit detection / protection function.

The time of soft start is:

$$T_{ss}[mS] = 0.35 \times C[\mu F]$$

The short circuit protection is triggered when a heavy loading makes output voltage drop and error amplifier output (COMP pin) is larger than  $V_{POS}$  (0.9V typ.). The SS pin capacitor will be charged to the SCP threshold voltage (0.8V typ.), then FP5139 output is disabled (internal pull-low) and the capacitor is discharged to low.

The time of short circuit protection is:

$$T_{scp}[mS] = 0.8 \times C[\mu F]$$

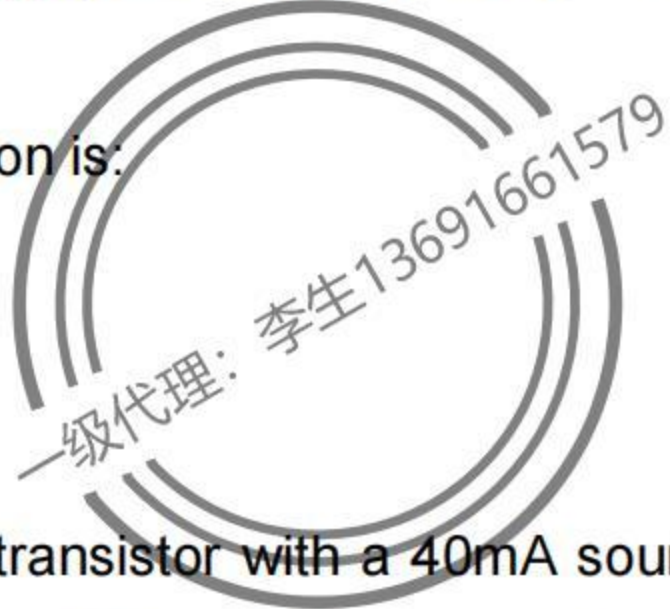

**Output Transistor**

The FP5139 has a totem-pole transistor with a 40mA source/sink current capability to drive an external NPN transistor or NMOS directly. The driving current capability depends on a resistor R that is connected to BR / CTL pin (Pin4) of FP5139. (see figure 13)

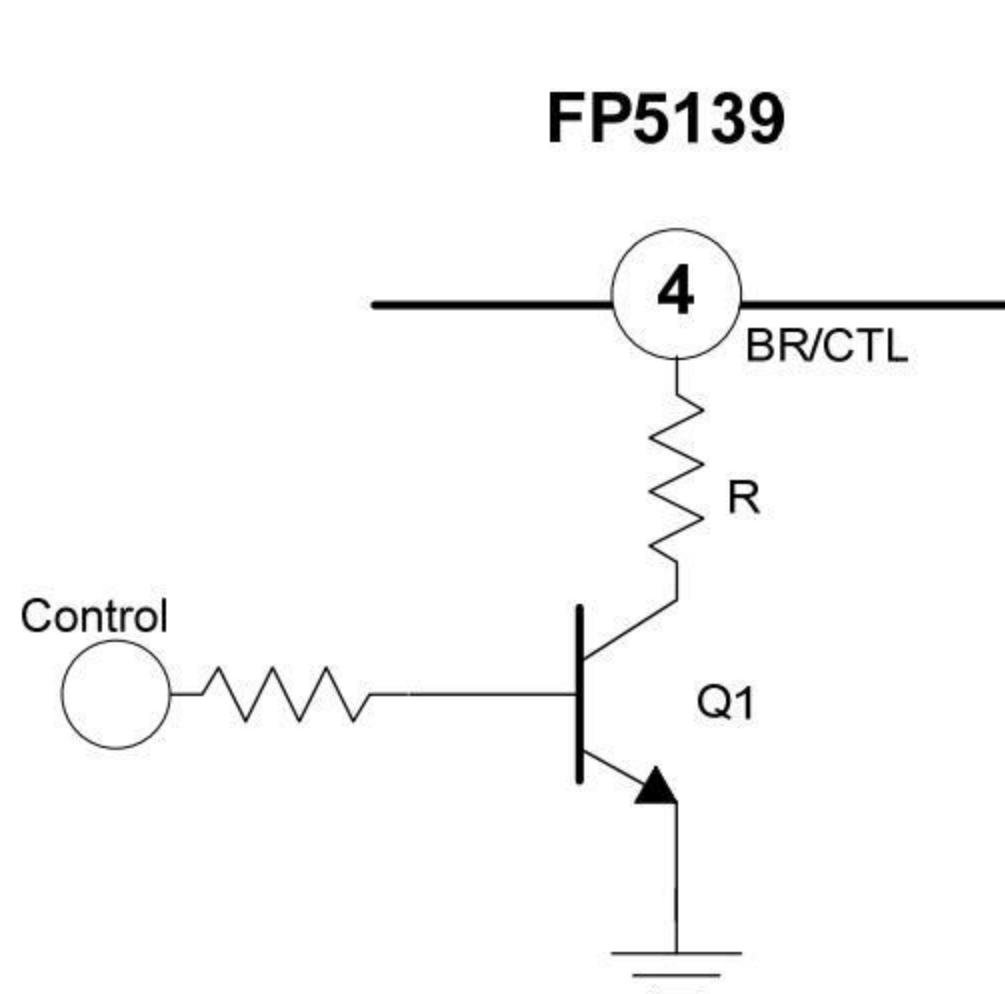

Figure 13 Output Transistor Driving Control Circuit

This datasheet contains new product information. Feeling Technology reserves the rights to modify the product specification without notice. No liability is assumed as a result of the use of this product. No rights under any patent accompany the sales of the product.

BR / CTL pin can also use to control the output of FP5139 for disable or enable function of system.

Control Pin	Q1	BR / CTL Pin	Output Transistor Function	Mode
Low	Off	Open	Disable	Stand-by
High	On	Bias Current	Enable	Operation



**Application Information**

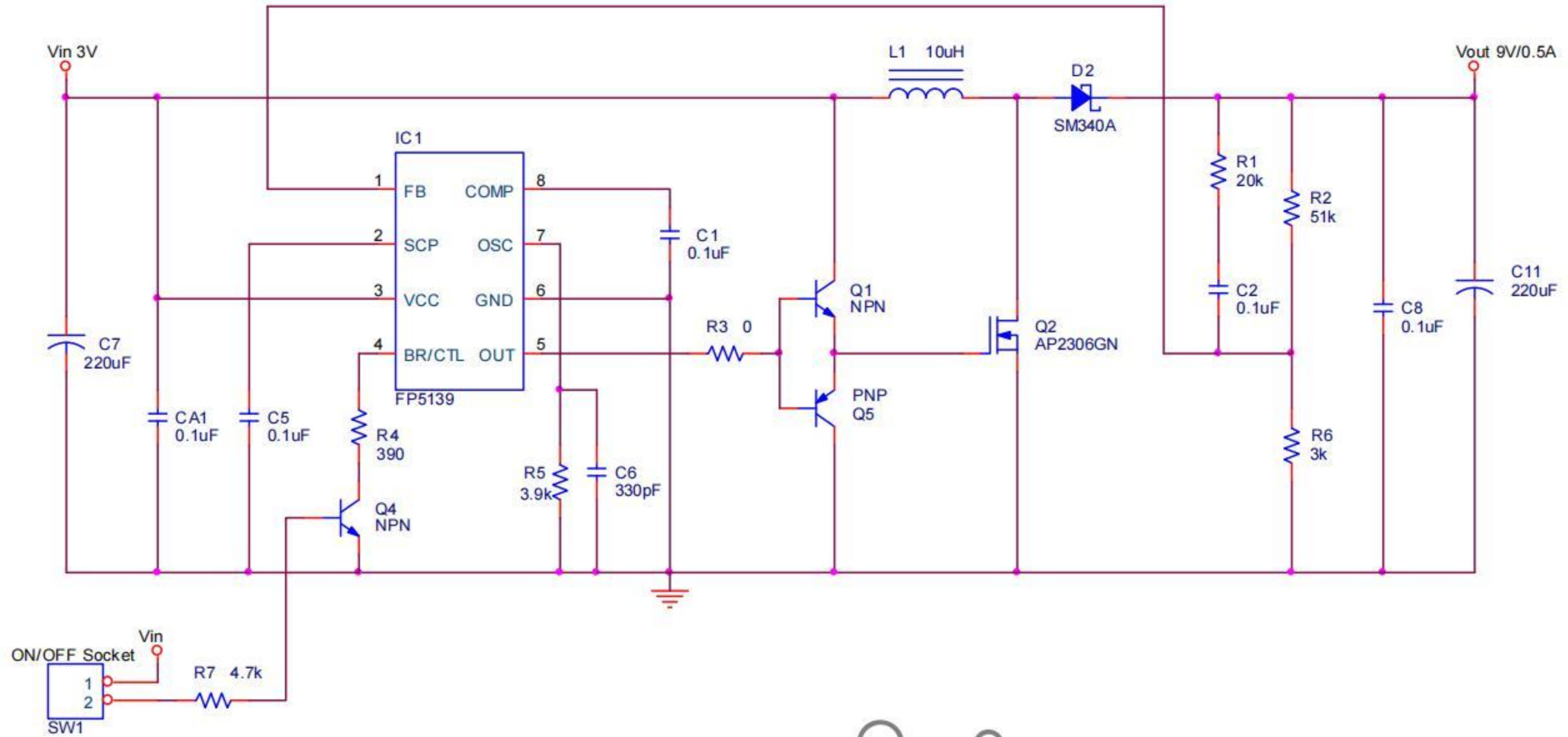

Figure14 DC 3V to DC 9V Boost Converter Circuit

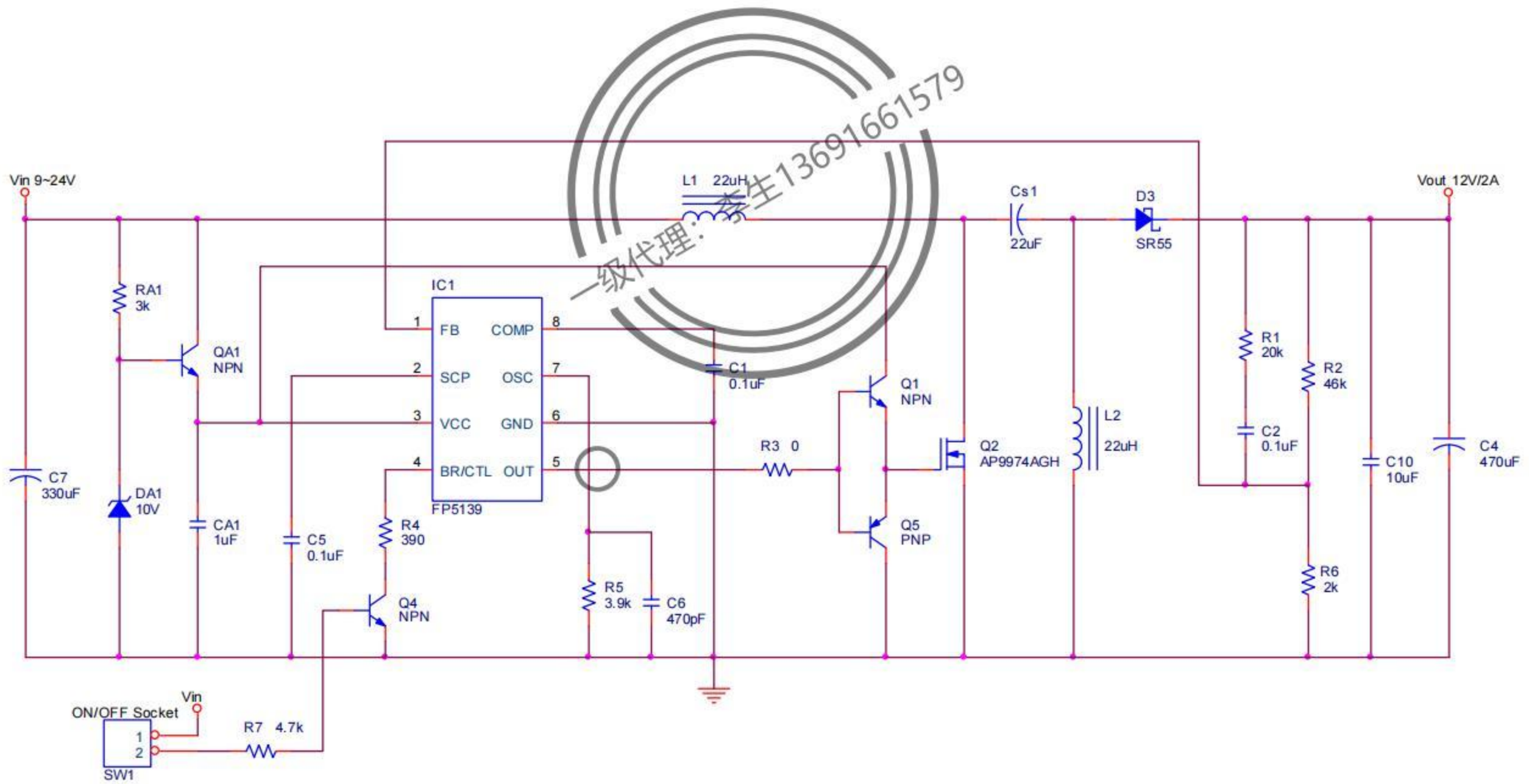

Figure15 DC 9V~24V to DC 12V SEPIC Converter Circuit

This datasheet contains new product information. Feeling Technology reserves the rights to modify the product specification without notice. No liability is assumed as a result of the use of this product. No rights under any patent accompany the sales of the product.

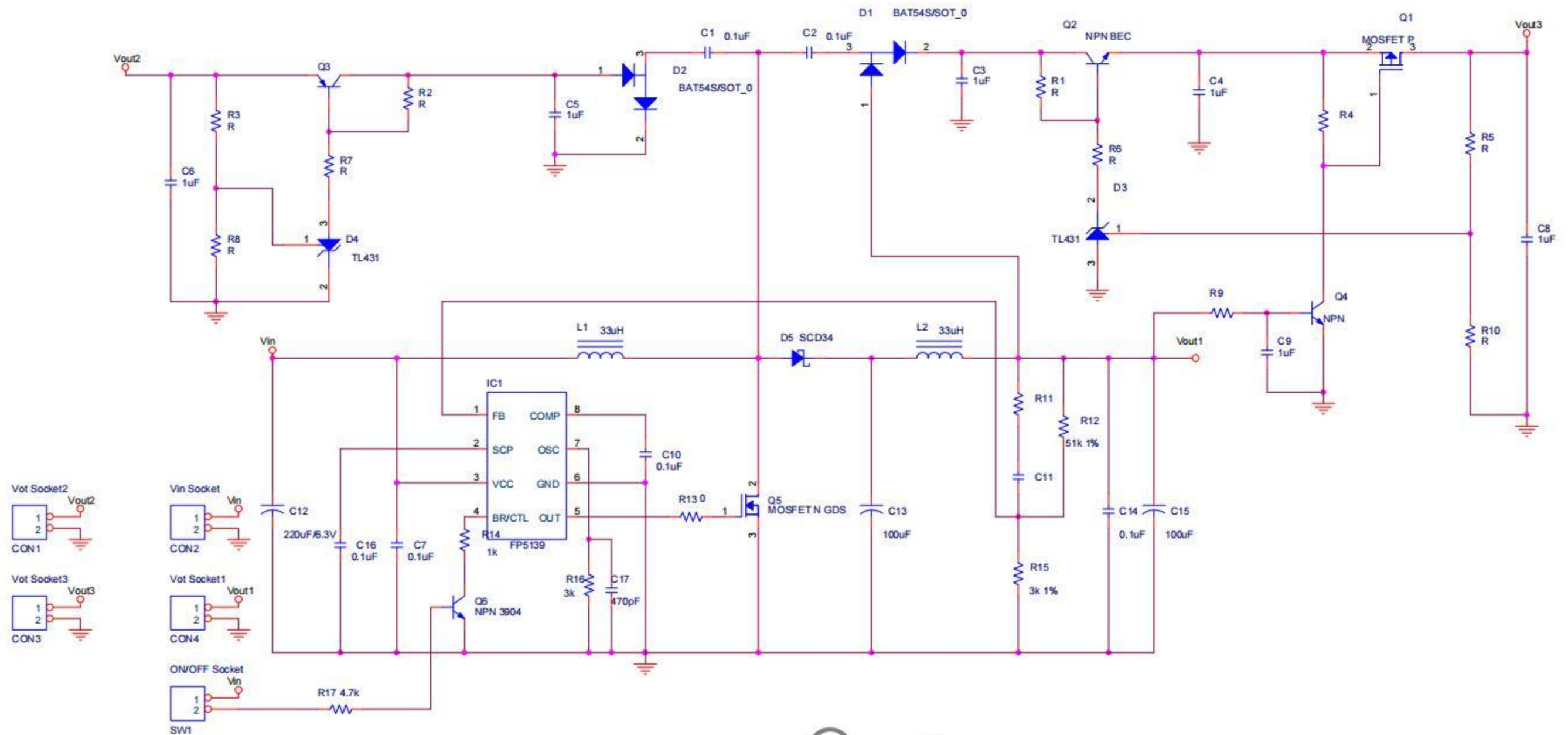

Figure16 Charge Pump DC-DC Converter Circuit

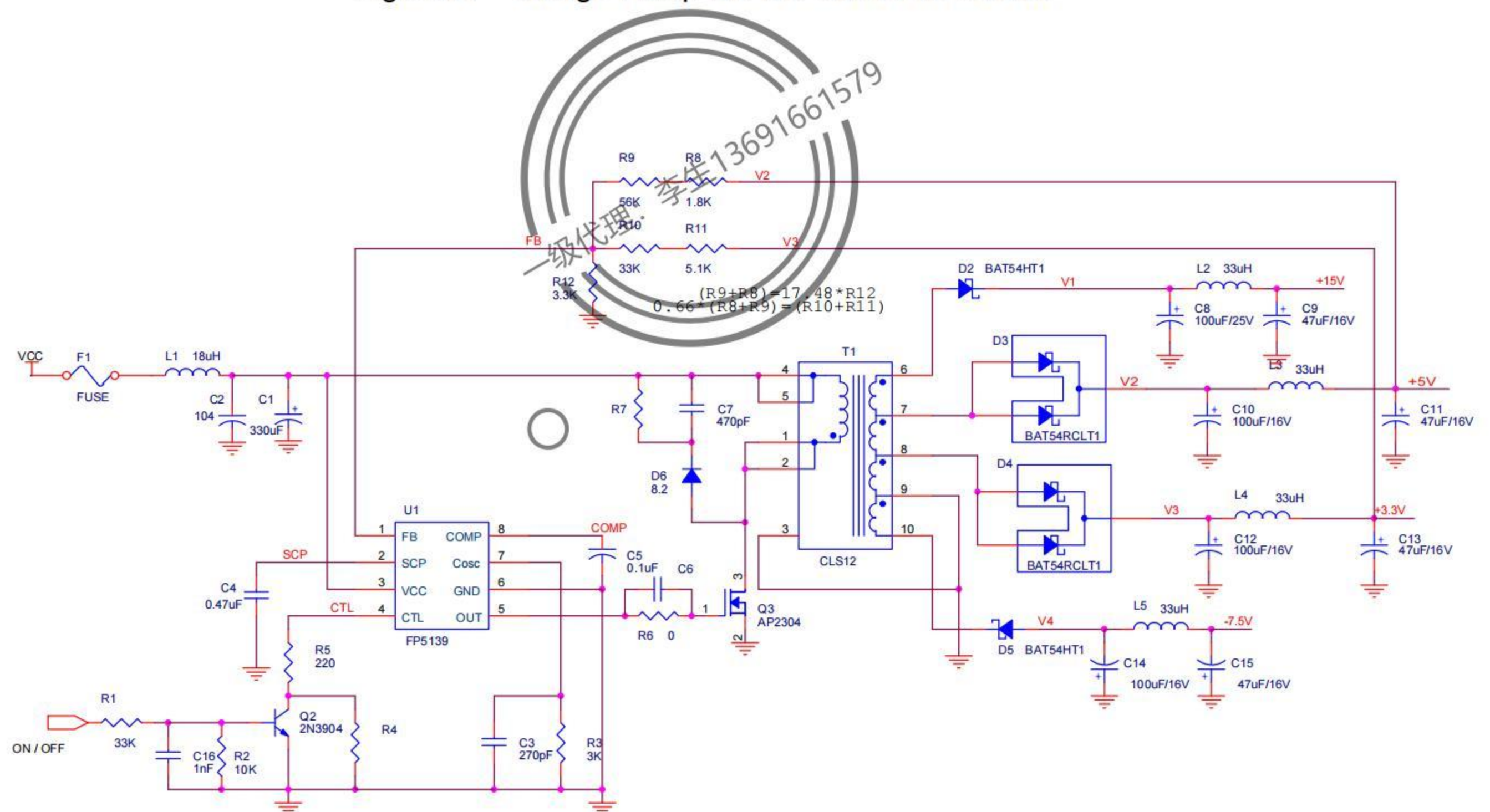

Figure17 Flyback Multi-Output DC-DC Converter Circuit

This datasheet contains new product information. Feeling Technology reserves the rights to modify the product specification without notice. No liability is assumed as a result of the use of this product. No rights under any patent accompany the sales of the product.

**Timing Waveform**

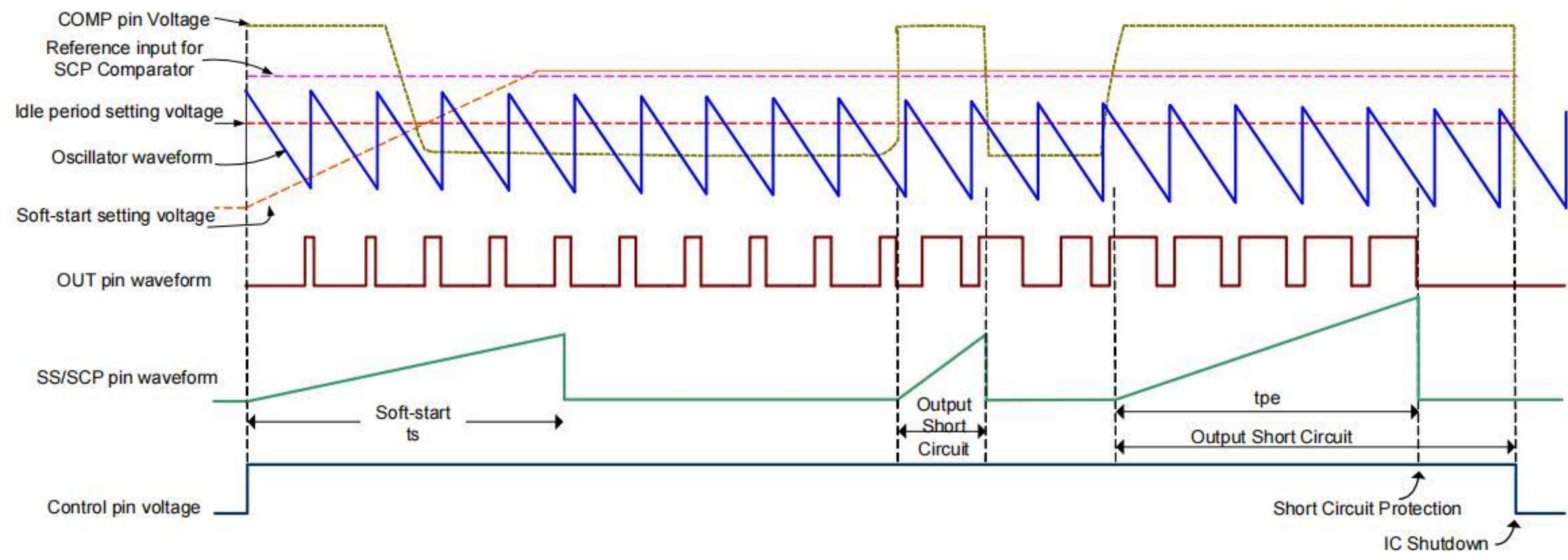
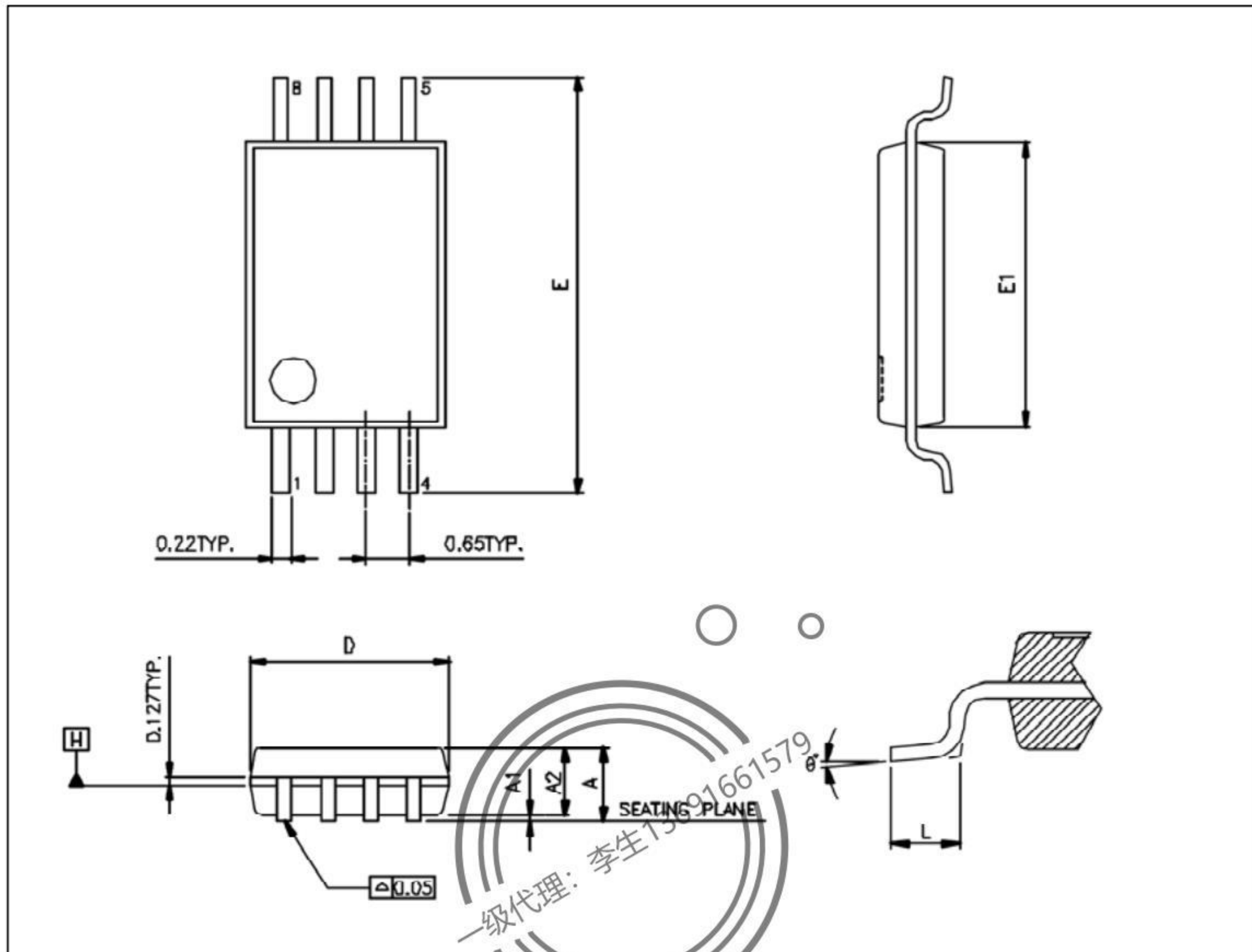

Figure18 FP5139 Timing Diagram



This datasheet contains new product information. Feeling Technology reserves the rights to modify the product specification without notice. No liability is assumed as a result of the use of this product. No rights under any patent accompany the sales of the product.

Package Outline  
TSSOP-8L



UNIT: mm

Symbols	Min. (mm)	Max. (mm)
A	0.200	1.200
A1	0.050	0.150
A2	0.960	1.060
D	2.900	3.100
E	6.400 BSC	
E1	4.300	4.500
L	0.450	0.750
$\theta^\circ$	0°	8°

Notes:

1. Package dimensions are in compliance with JEDEC outline: MO-153 AA.
2. Dimension "D" does not include molding flash, protrusions or gate burrs.
3. Dimension "E1" does not include inter-lead flash or protrusions.

This datasheet contains new product information. Feeling Technology reserves the rights to modify the product specification without notice. No liability is assumed as a result of the use of this product. No rights under any patent accompany the sales of the product.