

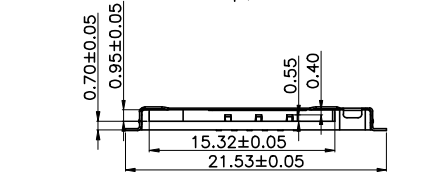

REV.	ECN NO OR DESCRIPTION	REVISED	DATE

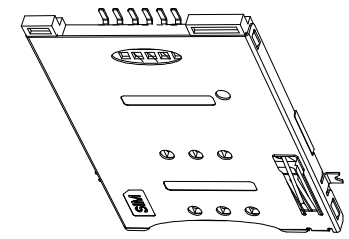

pin no.	name
C1	vcc of sim
C2	rst of sim
C3	clk of sim
C5	gnd of sim
C6	vpp of sim
C7	I/O of sim
C4/C8	n/a

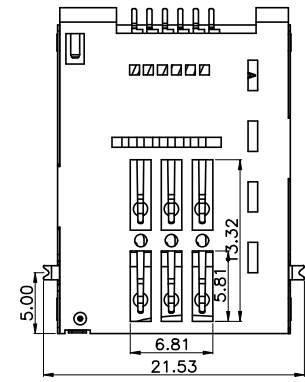
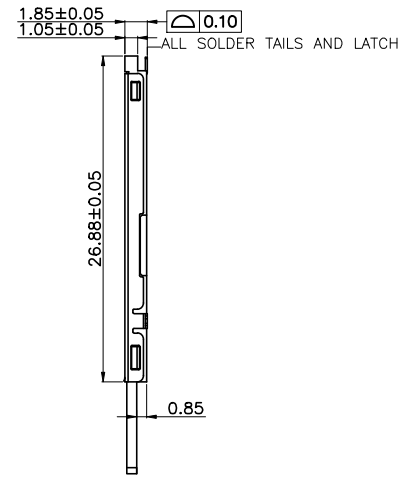
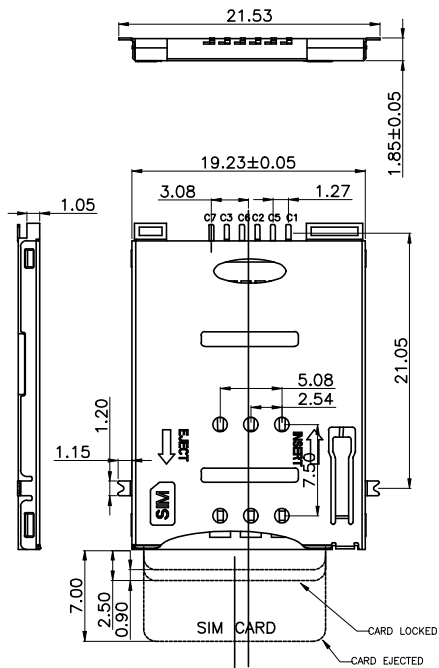
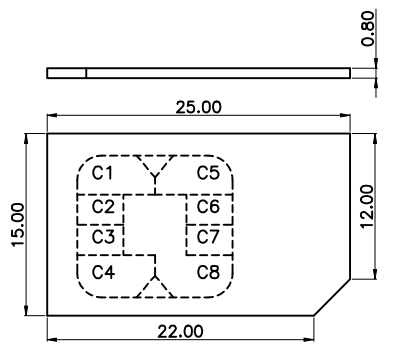
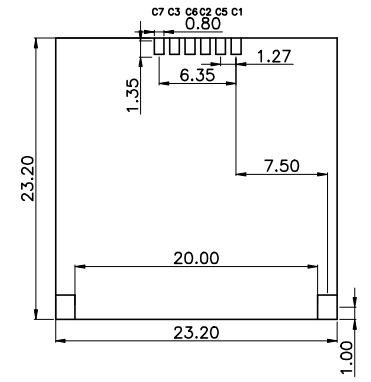

1.SPECIFICATIONS  
 INSULATION RESISTANCE: 500M min,AT DC 500V DC  
 WITHSTANDING VOLTAGE: 250V ACrms FOR 1 MINUTE  
 CONTACT RESISTANCE: 100M max. AT 10MA/20mV max  
 CURRENT RATING: 0.5A  
 VOLTAGE RATING: 5.0 vrms  
 OPERATING TEMP.RANGE:-55 C+85 C  
 MATING CYCLES: 5000 INSERTIONS

2.MATERIAL:  
 INSULATOR: H-TEMPERATURE PLASTIC,UL 94V-0,  
 COLOR"BLACK  
 TERMINAL: COPPER ALLOY,T=0.15mm  
 SHELL: STAINLESS STEEL,T=0.15mm

3.FINISH:  
 TERMINAL:50u" min NICKEL UNDERPLATED ON ALLOVER,GOLD PLATING  
 ON CONTACT ARER, 80u"min TIN ON SOLDER TAIL.  
 SHELL:50u" NICKEL UNDERPLATED ON ALLOVER, GOLD FLASH ON SOLDER  
 LATCH

UNLESS OTHERWISE SPECIFIED TOLERANCES		东莞市汉博电子科技有限公司 DONGGUAN HANBO TECHNOLOGY CO., LTD			
DECIMALS:	ANGLES:	TITLE	Mini Sim Card Push Push 6P Smt		
X :±0.5	X :±2°	DWN	xiong	SIM-207	
X.X :±0.20	X.X :±1°	CHKD	lee	SCALE:1:1	UNIT: mm
X.XX :±0.10		APVD	wang	SIZE: A4	SHEET:10F 1
		REV: A4			
CUSTOMER COPY					