

RF Power Barrel Capacitors for Dielectric Heating Equipment, R16 HQ Ceramic Dielectric



QUICK REFERENCE DATA	
DESCRIPTION	VALUE
Ceramic Class	1
Ceramic Dielectric	R16 HQ
Type	TOSZ 118078
Voltage (V_p)	30 000
Min. Capacitance (pF)	50
Max. Capacitance (pF)	75
Mounting	Screw terminal

MATERIAL

Capacitor elements made from class 1 ceramic dielectric with noble metal electrodes.

Connection terminals:

thread terminal, copper / brass, silver plated.

Allowable torque: M4 thread 3.5 Nm (31 lbf in)
M8 thread 6.0 Nm (53 lbf in)

FINISH

Capacitor body completely glazed.

MARKING

Type designator, capacitance value and tolerance, rated peak voltage, ceramic material code, production date code, manufacturer logo, serial no.

FEATURES

These capacitors feature a Q-factor of greater than 10 000 which makes them ideal in operating frequency range from 0.1 MHz up to 30 MHz where high voltages and currents are present. The TOSZ model can be used as replacement for fixed vacuum capacitors. The construction gives the capacitors an advantage over fixed vacuum capacitors, because there is no possibility of vacuum deterioration.

APPLICATIONS

Dielectric heating equipments in industrial segment

CAPACITANCE RANGE

50 pF to 75 pF

CAPACITANCE TOLERANCE

$\pm 10 \%$

CERAMIC DIELECTRICS

R16 High Q (TCC + 100 ppm/K)

RATED VOLTAGE

30 kV_p

DIELECTRIC STRENGTH TEST

60 000 V_{DC}, 2 min

140 % rated AC voltage (30 000 V_{RMS}, 50 Hz, 3 minutes)

RF-POWER TEST

140 % of rated power, for 5 minutes in a test generator circuit

DISSIPATION FACTOR

Max. 0.025 % (1 MHz)

INSULATION RESISTANCE

Min. 100 000 M Ω (at 25 °C)

OPERATING TEMPERATURE RANGE

-55 °C to +100 °C

SAP PART NUMBER AND ELECTRICAL DATA

PART NUMBER	CERAMIC	CAP. VALUES (pF)	RATED VOLTAGE (kV _p)	RATED POWER ⁽¹⁾ (kvar)	RATED CURRENT (A _{RMS})
BZ118078WV50036CB1	R16 High Q	50	30	Up to 800	150
BZ118078WV75036CB1		75			

Note

⁽¹⁾ The surface temperature during operation must not exceed +100 °C

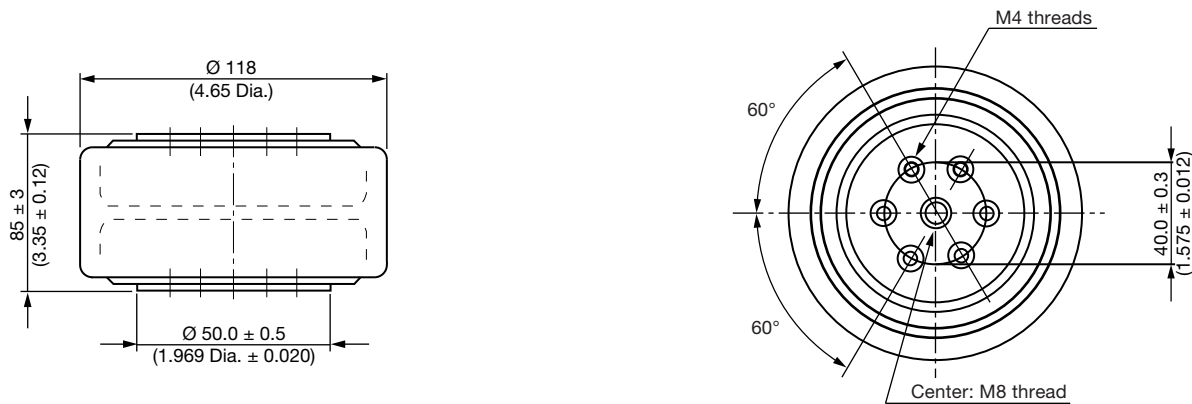
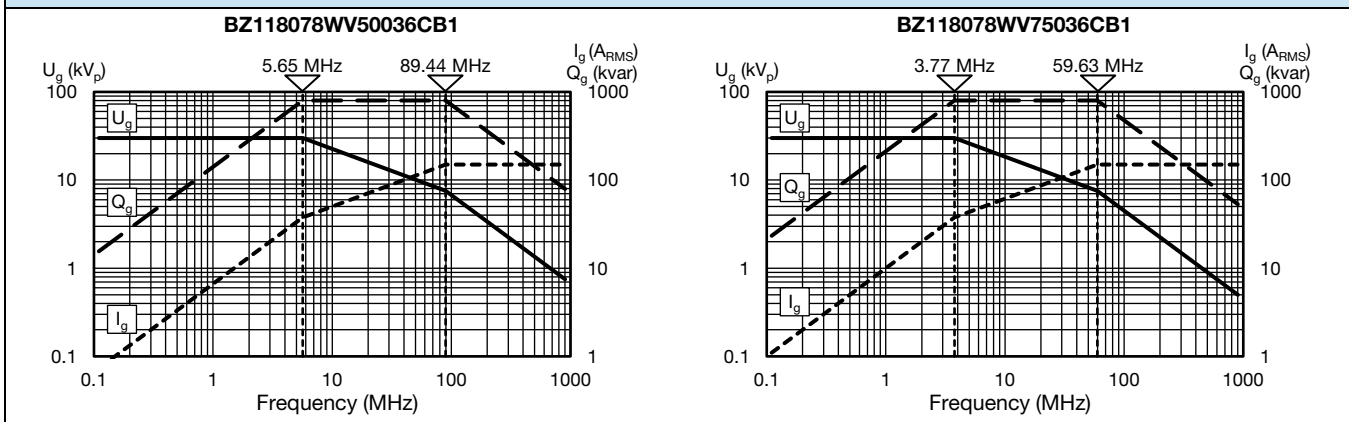
DIMENSIONS in millimeters (inches)

DERATING DIAGRAMS

RELATED DOCUMENTS

General Information

www.vishay.com/doc?22071



Disclaimer

ALL PRODUCT, PRODUCT SPECIFICATIONS AND DATA ARE SUBJECT TO CHANGE WITHOUT NOTICE TO IMPROVE RELIABILITY, FUNCTION OR DESIGN OR OTHERWISE.

Vishay Intertechnology, Inc., its affiliates, agents, and employees, and all persons acting on its or their behalf (collectively, "Vishay"), disclaim any and all liability for any errors, inaccuracies or incompleteness contained in any datasheet or in any other disclosure relating to any product.

Vishay makes no warranty, representation or guarantee regarding the suitability of the products for any particular purpose or the continuing production of any product. To the maximum extent permitted by applicable law, Vishay disclaims (i) any and all liability arising out of the application or use of any product, (ii) any and all liability, including without limitation special, consequential or incidental damages, and (iii) any and all implied warranties, including warranties of fitness for particular purpose, non-infringement and merchantability.

Statements regarding the suitability of products for certain types of applications are based on Vishay's knowledge of typical requirements that are often placed on Vishay products in generic applications. Such statements are not binding statements about the suitability of products for a particular application. It is the customer's responsibility to validate that a particular product with the properties described in the product specification is suitable for use in a particular application. Parameters provided in datasheets and / or specifications may vary in different applications and performance may vary over time. All operating parameters, including typical parameters, must be validated for each customer application by the customer's technical experts. Product specifications do not expand or otherwise modify Vishay's terms and conditions of purchase, including but not limited to the warranty expressed therein.

Hyperlinks included in this datasheet may direct users to third-party websites. These links are provided as a convenience and for informational purposes only. Inclusion of these hyperlinks does not constitute an endorsement or an approval by Vishay of any of the products, services or opinions of the corporation, organization or individual associated with the third-party website. Vishay disclaims any and all liability and bears no responsibility for the accuracy, legality or content of the third-party website or for that of subsequent links.

Except as expressly indicated in writing, Vishay products are not designed for use in medical, life-saving, or life-sustaining applications or for any other application in which the failure of the Vishay product could result in personal injury or death. Customers using or selling Vishay products not expressly indicated for use in such applications do so at their own risk. Please contact authorized Vishay personnel to obtain written terms and conditions regarding products designed for such applications.

No license, express or implied, by estoppel or otherwise, to any intellectual property rights is granted by this document or by any conduct of Vishay. Product names and markings noted herein may be trademarks of their respective owners.