

Multilayer Ceramic Capacitors (High dielectric type)

UMK107 B7104KAHT

- [Notes]
- This document is for reference use only and does not guarantee the specifications of the products.
 - The contents of this document are based on the existing April 1, 2020.
 - This document is subject to change for improvements or others without notice.
 - Please request and agree to the specification document of the products before purchasing and using them regardless of types of applications.
 - Please check and comply with the usage conditions and precautions described in this specification. Before use, please be sure to verify and validate the products under intended operating environmental conditions with the products being installed in actual devices.

1. Scope

This specification shall apply to multilayer ceramic chip capacitors used for automotive electronic equipment. Notwithstanding the foregoing, this specification shall not apply to any equipment related to vehicle driving control (automotive functions of running, turning and stopping) and driving safety, and please do not use the products for such equipment. See basic information and precautions described in Section 6 for details.

2. Part Numbering System

Part number is indicated as follows:

(Example) $\frac{U}{①}$ MK $\frac{107}{②}$ $\frac{\Delta}{③}$ $\frac{B7}{④}$ Capacitance $\frac{K}{⑤}$ $\frac{A}{⑥}$ $\frac{HT}{⑦}$

①Rated voltage

Code	Voltage [VDC]
U	50 V

②Size

Code	L × W [mm]
107	1.6x0.8

③Control Code
Per Table 1
※Δ: space (blank)

④Temperature Characteristic

Code	Reference standard	Capacitance change rate	Temperature range ※	Reference temperature
B7	EIA	X7R	-55 to +125 °C	25°C

⑤Tolerance

Code	Tolerance
K	± 10 %

※Temperature range includes TC guarantee temperature range and operating temperature range.

⑥Thickness

Type	Code	Thickness [mm]
107	A	0.8

⑦Individual specification, Packaging

Code	Individual specification	Packaging type
HT	H:MLCC for Automotive	Taping

3. Shape, Structure, and Dimension

Figure 1: Shape and structure

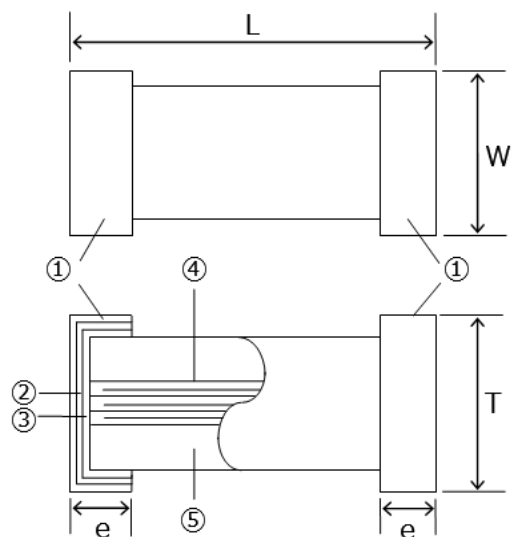

No.	Name	Material
①	Terminal Electrodes (Surface)	Sn Plating
②	Terminal Electrodes	Ni Plating
		Cu Plating
③	External Electrodes	Ni
④	Internal Electrodes	Ni
⑤	Dielectric	Barium titanate

Table 1: Dimensions

Item type	Control code※	Dimension [mm]			
		L	W	T	e
107	△	1.6 ±0.10	0.8 ±0.10	Per Table 2	0.35 ±0.25

※△: space (blank)

4. Rated Value

Table 2: Rated Value/Part Number List

Part number ※1	Temp. char ※1	Cap.	IR [min.]	DF [max]	Thickness [mm]	Soldering method	
						Wave	Reflow
UMK107 B7104KAHT	X7R	0.1 uF	100 MΩ·μF	3.5 %	0.8 ±0.10	×	○

※1 conforms to EIA or JIS.

5. Functions and Test Methods

Test Conditions:

Standard test conditions shall be temperature of 5 to 35°C, relative humidity of 45 to 85%, and air pressure of 86 to 106 kPa.

Tests shall be conducted at temperature of 25 ± 3°C, relative humidity of 60 to 70% and air pressure of 86 to 106 kPa if test results are suspicious. Unless otherwise specified, all tests shall be conducted under the standard test conditions.

番号 No	AEC-Q200 Rev.D Test Item/試験項目	Qty 数量	Specification 規格値		AEC-Q200 Rev.D Test Method/試験方法
1	Pre- and Post-Stress Electrical test ストレス前後の電気試験		Measurement at 25±5 deg. C 測定は25±5°Cで行う。		
2	Heat treatment 熱処理		Value shall be measured after test sample is heat-treated at 150 +0/-10°C for an hour and kept at room temperature for 24±2 hours 試料を150+0/-10°Cの温度で1時間熱処理を行い、室温に24±2時間放置した後、値を測定する。		
3	High Temperature Exposure (Storage) 耐熱性 (高温放置)	77	Appearance 外観	No abnormality 異常のないこと	Heat treatment specified in this specification shall be conducted prior to test. Unpowered 1000 hours. The maximum operating temperature shall be used. Measurement shall be performed after test sample following the test is heated at 150 +0/-10°C for an hour and kept at room temperature for 24±2 hours. 試験に先立ち、この仕様の番号2の熱処理を行う。 試験温度: 最高使用温度 試験時間: 1000時間 試験後の測定は、試料を番号2の熱処理を行い、室温中に24±2時間放置した後に行う。
			Cap. Change 容量変化	Per Table 3 表-3参照	
			DF tan δ	Per Table 3 表-3参照	
			IR 絶縁抵抗	Per Table 3 表-3参照	
4	Temperature Cycling 温度サイクル	77	Appearance 外観	No abnormality 異常のないこと	Heat treatment specified in this specification shall be conducted prior to test 1000 cycles (Minimum operating temperature to Maximum operating temperature) 30 min. maximum dwell time at each temperature extreme. 1 min. maximum transition time. Measurement shall be performed after test sample following the test is heated at 150 +0/-10°C for an hour and kept at room temperature for 24±2 hours. 試験に先立ち、この仕様の番号2の熱処理を行う 試験温度: 最低使用温度～最高使用温度 試験時間: 1000サイクル 定常時間: 30分。移行時間: 1分以内 試験後の測定は、試料を番号2の熱処理を行い、室温中に24±2時間放置した後に行う
			Cap. Change 容量変化	Per Table 3 表-3参照	
			DF tan δ	Per Table 3 表-3参照	
			IR 絶縁抵抗	Relevant MLCCs shall satisfy the Specifications described in "Rated value list". 定格値一覧を 満足 すること	

番号 No	AEC-Q200 Rev.D Test Item/試験項目	Qty 数量	Specification 規格値		AEC-Q200 Rev.D Test Method/試験方法
5	Destructive Physical Analysis 破壊解析	10	No abnormality 異常のないこと		Per EIA-469 EIA-469に従う。
6	Biased Humidity 耐湿負荷	77	Appearance 外観	No abnormality 異常のないこと	Heat treatment specified in this specification shall be conducted prior to test. 1000 hours, 85°C/85% RH. Rated voltage and 1.3 to 1.5 volts Measurement shall be performed after test sample following the test is heated at 150 +0/-10°C for an hour and kept at room temperature for 24±2 hours. 試験に先立ち、この仕様の番号2の熱処理を行う 試験温度: 85°C。試験湿度: 85%RH。 試験時間: 1000時間 印加電圧: 定格電圧、1.3~1.5V 試験後の測定は、試料を番号2の熱処理を行い、室温中に24±2時間放置した後にを行う
			Cap. Change 容量変化	Per Table 3 表-3参照	
			DF tan δ	Per Table 3 表-3参照	
			IR 絶縁抵抗	Per Table 3 表-3参照	
7	Operational Life 高温負荷	77	Appearance 外観	No abnormality 異常のないこと	Heat treatment specified in this specification shall be conducted prior to test. The maximum operating temperature and rated voltage shall be used The maximum operating temperature and rated voltage shall be used Measurement shall be performed after test sample following the test is heated at 150 +0/-10°C for an hour and kept at room temperature for 24±2 hours. 試験に先立ち、この仕様の番号2の熱処理を行う 試験温度: 最高使用温度 試験時間: 1000時間 印加電圧: 定格電圧 試験後の測定は、試料を番号2の熱処理を行い、室温中に24±2時間放置した後にを行う
			Cap. Change 容量変化	Per Table 3 表-3参照	
			DF tan δ	Per Table 3 表-3参照	
			IR 絶縁抵抗	Per Table 3 表-3参照	
8	External Visual 外観		No abnormality 異常のないこと		Visual inspection shall be performed. 外観検査を行う。
9	Physical Dimension 寸法	30	Per Table 1 and Rated value list 表-1寸法、定格値一覧による		Verify physical dimensions to the applicable device specification 仕様書に合わせて寸法の確認を行う。

番号 No	AEC-Q200 Rev.D Test Item/試験項目	Qty 数量	Specification 規格値		AEC-Q200 Rev.D Test Method/試験方法
10	Resistance to Solvents 耐溶剤性	30	Appearance 外観	No abnormality 異常のないこと	Per MIL-STD-202 Method 215 Heat treatment specified in this specification shall be conducted prior to test Add Aqueous wash chemical OKEMCLEAN (A 6% concentrated Oakite cleaner) or equivalent MIL-STD-202 Method 215に従う。 試験に先立ち、この仕様の番号2の熱処理を行う 水洗浄OKEMCLEAN (A 6% concentrated Oakite cleaner)又は同等品
			Cap. Change 容量変化	Relevant MLCCs shall satisfy the Specifications described in "Rated value list". 定格値一覧を 満足 すること	
			DF tan δ	Relevant MLCCs shall satisfy the Specifications described in "Rated value list". 定格値一覧を 満足 すること	
			IR 絶縁抵抗	Relevant MLCCs shall satisfy the Specifications described in "Rated value list". 定格値一覧を 満足 すること	

番号 No	AEC-Q200 Rev.D Test Item/試験項目	Qty 数量	Specification 規格値		AEC-Q200 Rev.D Test Method/試験方法
11	Mechanical Shock 衝撃試験	30	Appearance 外観	No abnormality 異常のないこと	Heat treatment specified in this specification shall be conducted prior to test Three shocks in each direction should be applied along 3 mutually perpendicular axes of the test specimen (18 shocks). Peak value: 1500g. Peak value: 1500g. Test pulse: Half-sine. Velocity change: 4.7m/s. 試験に先立ち、この仕様の番号2の熱処理を行う 互いに直行する3軸に沿って、各方向に3回(計18回)行う。 最大加速度:1500g。持続時間:0.5ms。波形:半波正弦波。速度変化:4.7m/s。
			Cap. Change 容量変化	Relevant MLCCs shall satisfy the Specifications described in "Rated value list". 定格値一覧を満足すること	
			DF tan δ	Relevant MLCCs shall satisfy the Specifications described in "Rated value list". 定格値一覧を満足すること	
			IR 絶縁抵抗	Relevant MLCCs shall satisfy the Specifications described in "Rated value list". 定格値一覧を満足すること	

番号 No	AEC-Q200 Rev.D Test Item/試験項目	Qty 数量	Specification 規格値		AEC-Q200 Rev.D Test Method/試験方法
12	Vibration 耐振性	30	Appearance 外観	No abnormality 異常のないこと	Heat treatment specified in this specification shall be conducted prior to test 5g's for 20 min., 12 cycles each of 3 orientations Test from 10-2000 Hz 試験に先立ち、この仕様の番号2の熱処理を行う 振動周波数:10Hz~2000Hz (20分間) 加速度:5g's 互いに垂直なる3方向に12回ずつ(計36回)行う。
			Cap. Change 容量変化	Relevant MLCCs shall satisfy the Specifications described in "Rated value list". 定格値一覧を 満足すること	
			DF tan δ	Relevant MLCCs shall satisfy the Specifications described in "Rated value list". 定格値一覧を 満足すること	
			IR 絶縁抵抗	Relevant MLCCs shall satisfy the Specifications described in "Rated value list". 定格値一覧を 満足すること	
13	Resistance to Soldering Heat はんだ耐熱性	30	Appearance 外観	No abnormality 異常のないこと	Heat treatment specified in this specification shall be conducted prior to test No pre-heat of samples Dipping Solder: 260 \pm 5 $^{\circ}$ C. Time: 10 \pm 1 sec. Measurement shall be performed after test sample following the test is heated at 150 +0/-10 $^{\circ}$ C for an hour and kept at room temperature for 24 \pm 2 hours. 試験に先立ち、この仕様の番号2の熱処理を行う はんだ温度:260 \pm 5 $^{\circ}$ C。 浸漬時間:10 \pm 1秒 試験後の測定は、試料を番号2の熱処理を行い、室温中に24 \pm 2時間放置した後に行う
			Cap. Change 容量変化	Per Table 3 表-3参照	
			DF tan δ	Per Table 3 表-3参照	
			IR 絶縁抵抗	Relevant MLCCs shall satisfy the Specifications described in "Rated value list". 定格値一覧を 満足すること	

番号 No	AEC-Q200 Rev.D Test Item/試験項目	Qty 数量	Specification 規格値		AEC-Q200 Rev.D Test Method/試験方法
14	ESD	30	Appearance 外観	No abnormality 異常のないこと	Heat treatment specified in this specification shall be conducted prior to test Per AEC-Q200-002 試験に先立ち、この仕様の番号2の熱処理を行う AEC-Q200-002に従う
			IR 絶縁抵抗	Relevant MLCCs shall satisfy the Specifications described in "Rated value list". 定格値一覧を 満足すること	
15	Solderability はんだぬれ性	15	More than 95% of terminal electrode shall be covered with fresh solder 端子電極部分の95%以上が新しい はんだで覆われていること		(a) Solder at 235±5°C for 5sec.Pb Free Solder. (a) はんだ温度:235±5°C浸漬時間:5秒 (b) Solder at 215±5°C for 5sec.SnPb Solder (b) はんだ温度:215±5°C 浸漬時間:5秒 (c) Solder at 260±5°C for 7sec.Wave Soldering Pb Free Solder (c) はんだ温度:260±5°C浸漬時間:7秒
16	Temperature Characteristic 静電容量温度特性	30	Per P.1 for ④ P1④参照		Heat treatment specified in this specification shall be conducted prior to test Capacitance shall be measured at room temperature as well as minimum and maximum operating temperatures. 試験に先立ち、この仕様の番号2の熱処理を行う 最低使用温度～最高使用温度での容量値を測定する。
17	Board Flex 耐基板曲げ性	30	Appearance 外観	No abnormality 異常のないこと	Heat treatment specified in this specification shall be conducted prior to test Test sample is soldered onto the test board shown in Fig 3. The board is bent 2.0mm for 60 seconds as shown in Fig.4. Measurement shall be conducted as the board is bent 2.0mm 試験に先立ち、この仕様の番号2の熱処理を行う 試料を図-3に示すような試験基板にはんだ付けする。 試験方法:試験状態は図-4に示す。 たわみ2mmにて60秒間力を加える。 測定は2mmにたわんだ状態にて行う。
			Cap. Change 容量変化	±12.5%	

番号 No	AEC-Q200 Rev.D Test Item/試験項目	Qty 数量	Specification 規格値		AEC-Q200 Rev.D Test Method/試験方法
18	Terminal Strength 端子電極固着力	30	Appearance 外観	No abnormality 異常のないこと	Per AEC-Q200-006 Test sample is soldered onto the test board shown in Fig 2. 0603 or greater (case size): 17.7N for 60±5 sec 0402 (case size): 5N for 30±5 sec. 0201 (case size): 2N for 30±5 sec AEC-Q200-006に従う 試料を図-2の試験基板にはんだ付けする。 1608形状以上: 17.7N、60±5秒間力を加える。 1005形状 : 5N、30±5秒間力を加える 0603形状 : 2N、30±5秒間力を加える
19	Beam Load Test 抗折試験	30	Destruction value should exceed 5N. 5N以上		Per AEC-Q200-003 AEC-Q200-003に従う。 

Table 3 Cap.,DF, and IR Changes after Test

Part number	Resistance to Soldering Heat/ Thermal Shock		High Temperature Loading/ High Temperature Exposure (Storage)			Humidity Loading		
	Cap.chg rate	DF [max]	Cap.chg rate	DF [max]	IR [min]	Cap.chg rate	DF [max]	IR [min]
UMK107 B7104KAHT	±15.0%	3.5%	±15.0%	7%	50MΩ・μF	±15.0%	7%	10MΩ・μF

Fig. 2: Board / Test Jig of Adhesive Force of Terminal Electrodes, Vibration, and Thermal Shock

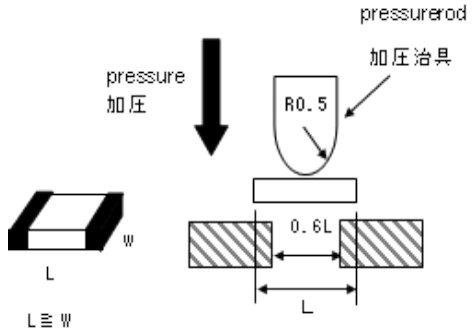
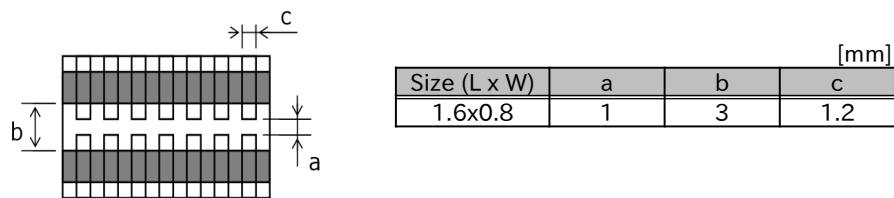

Material: Glass epoxy board [JIS C 6484]
 Copper foil (Thickness: 0.035mm)
 Solder resist

Remarks: Uniform soldering shall be conducted with solder by using soldering iron or soldering oven.
 Soldering shall be conducted with care to avoid abnormality such as heat shock.

Fig. 3: Board for Bending Strength Test

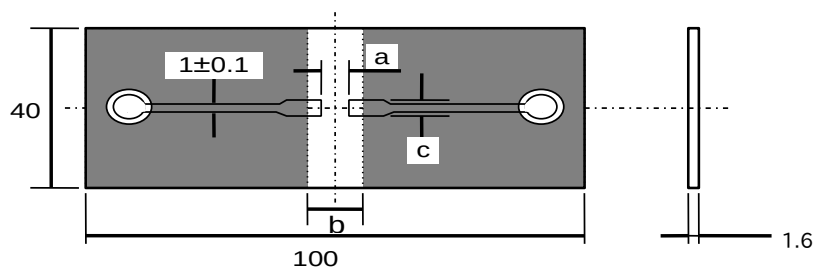

Material: Glass epoxy board [JIS C 6484]
 Copper foil (Thickness: 0.035 mm)
 Solder resist

Size (L x W)	a	b	c
1.6x0.8	1	3	1.2

Fig.4

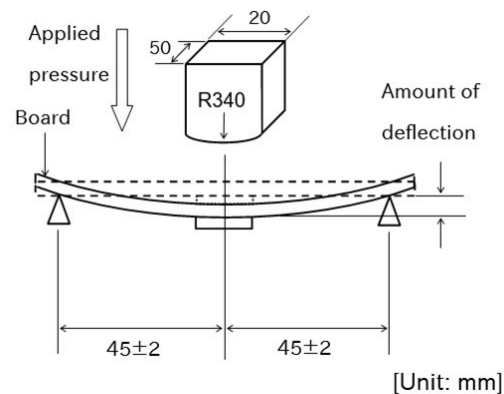

Apply pressure at the rate of 0.5mm/sec.
 until amount of deflection reaches 2.0mm.

6. Basic Information and Others

6-1. Basic Information

6-1-1. Equipment Intended for Use

The products listed in this specification are intended for general purpose and standard use in general electronic equipment (e.g., AV equipment, OA equipment, home electric appliances, office equipment, information and communication equipment including, without limitation, mobile phone, and PC) and other equipment specified in catalog or the individual product specification sheets.

TAIYO YUDEN has the line-up of the products intended for use in automotive electronic equipment, telecommunications infrastructure and industrial equipment, or medical devices classified as GHTF Classes A to C (Japan Classes I to III). Therefore, when using our products for these equipment, please check available applications specified in catalog or the individual product specification sheets and use the corresponding products.

6-1-2. Equipment Requiring Inquiry

Please be sure to contact TAIYO YUDEN for further information before using the products listed in this specification for the following equipment (excluding intended equipment as specified in catalog or the individual product specification sheets) which may cause loss of human life, bodily injury, serious property damage and/or serious public impact due to a failure or defect of the products and/or malfunction attributed thereto.

- (1) Transportation equipment (automotive powertrain control system, train control system, and ship control system, etc.)
- (2) Traffic signal equipment
- (3) Disaster prevention equipment, crime prevention equipment
- (4) Medical devices classified as GHTF Class C (Japan Class III)
- (5) Highly public information network equipment, data processing equipment (telephone exchange, and base station, etc.)
- (6) Any other equipment requiring high levels of quality and/or reliability equal to the equipment listed above

6-1-3. Equipment Prohibited for Use

Please do not incorporate our products into the following equipment requiring extremely high levels of safety and/or reliability.

- (1) Aerospace equipment (artificial satellite, rocket, etc.)
- (2) Aviation equipment *1
- (3) Medical devices classified as GHTF Class D (Japan Class IV), implantable medical devices *2
- (4) Power generation control equipment (nuclear power, hydroelectric power, thermal power plant control system, etc.)
- (5) Undersea equipment (submarine repeating equipment, underwater work equipment, etc.)
- (6) Military equipment
- (7) Any other equipment requiring extremely high levels of safety and/or reliability equal to the equipment listed above

*Notes:

1. There is a possibility that our products can be used only for aviation equipment that does not directly affect the safe operation of aircraft (e.g., in-flight entertainment, cabinlight, electric seat, cooking equipment) if such use meets requirements specified separately by TAIYO YUDEN. Please be sure to contact TAIYO YUDEN for further information before using our products for such aviation equipment.
2. Implantable medical devices contain not only internal unit which is implanted in a body, but also external unit which is connected to the internal unit.

6-1-4. Limitation of Liability

Please note that unless you obtain prior written consent of TAIYO YUDEN, TAIYO YUDEN shall not be in any way responsible for any damages incurred by you or third parties arising from use of the products listed in this specification for any equipment that is not intended for use by TAIYO YUDEN, or any equipment requiring inquiry to TAIYO YUDEN or prohibited for use by TAIYO YUDEN as described above.

■ Safety Design

When using our products for high safety and/or reliability-required equipment or circuits, please fully perform safety and/or reliability evaluation. In addition, please install (i) systems equipped with a protection circuit and a protection device and/or (ii) systems equipped with a redundant circuit or other system to prevent an unsafe status in the event of a single fault for a failsafe design to ensure safety.

6-2. Precautions in Usage

- This specification does not cover the products when Sn-Zn lead free solder is used.
- When the products are used in places where dew condensation develops and/or where corrosive gas such as hydrogen sulfide, sulfurous acid, or chlorine exists in the air, insulation (dielectric) deterioration may occur. Please do not use capacitors under such environmental conditions.

6-3. Storage Conditions

- Temperature and humidity in storage area shall be controlled carefully to maintain the solderability of terminal electrodes and to keep the packaging material in good condition. Humidity should especially be kept as low as possible.
- The ambient temperature must be kept from 5 to 40°C. Even under ideal storage conditions, capacitor electrode solderability decreases with time. Therefore, ceramic chip capacitors should be used within six (6) months from the time of delivery. If the period is exceeded, please check solderability before using the capacitors.
- The packaging material should be kept where no chlorine or sulfur exists in the air. T

6-4. RoHS Compliance

- The products conform to RoHS.
- “RoHS compliance” means that the products do not contain lead, cadmium, mercury, hexavalent chromium, PBB ,PBDE ,DEHP,BBP,DBP,DIBP referring to Directive (EU)2015/863, except other non-restricted substances or impurities which cannot be technically removed at refining process.
- The products are halogen-free products.

6-5. Resin Coating:

- Coating/molding capacitors with resin may have negative effects on the functions of the products.
- When the products are coated/molded with resin, please check effects on the products by analyzing them in actual applications/devices before use.

6-6. AEC-Q200 Reliability Tests and Approval

The products have been tested according to AEC-Q200, the reliability test standard for approval of passive components used in automotive applications.

Upon your request, we submit the test results. After validating and verifying whether or not the products meet the specifications of your specific equipment requiring AEC-Q200, please determine whether or not the products are used therein.

In addition, the term “AEC-Q200 qualified” as used in this specification shall mean that the products have been tested according to AEC-Q200.

The scope of performance warranty for the products shall be only rated value, and shape and dimensions described in next page.

Please contact us if you have further requirements or questions.

7. Packaging

[Tape Packaging: 107, 212, 316, 325, and 432 Type]

- 107-case-type products: paper tape and embossed tape (taping code: R)
- 212 and 316-case-type products with 0.85mm-thickness: paper tape
- Embossed tape: Products with 1.15mm-thickness or over and 325-case-type products with 0.85mm-thickness.

Dimensions [Unit: mm]※1

Type	A	B
107	1.0±0.2	1.8±0.2
	1.1±0.2 ※2	1.9±0.2 ※2
	1.2±0.2 ※3	2.0±0.2 ※3
212	1.65±0.2	2.4±0.2

Type	A	B
316	2.0±0.2	3.6±0.2
	2.1±0.2 ※4	3.7±0.2 ※4
325	2.8±0.2	3.6±0.2
	3.0±0.2 or 3.1±0.2 ※5	3.7±0.2 or 4.0±0.2 ※5
432	3.7±0.2	5.05±0.2

Dimensions [Unit: mm]

Type	C	D	E	F	G	H	J	K ※1	t ※1
107※3	8.0 ± 0.3	3.5 ± 0.05	1.75 ± 0.1	4.0 ± 0.1	2.0 ± 0.05	4.0 ± 0.1	φ 1.5 +0.1/-0	1.4 max.	0.25±0.1
107~ 325								- (Paper tape)	1.1 max. (Paper tape)
								- (Paper tape)	1.2 max. (Paper tape) ※2
325※5	12.0 ± 0.3	5.5 ± 0.05		8.0 ± 0.1				3.4 max.	0.6 max.
432								3.7 max.	
								4.0 max.	

※1. A, B, K, t: Sufficient clearances are secured.

※2.*MK107B*****T

※3.*MK107B*****RE

※4.*MK316B*****T

※5.*MK325A**157****,*MK325A**227****,*MK325A**337****,*MK325A**476**** (12mm width tape)

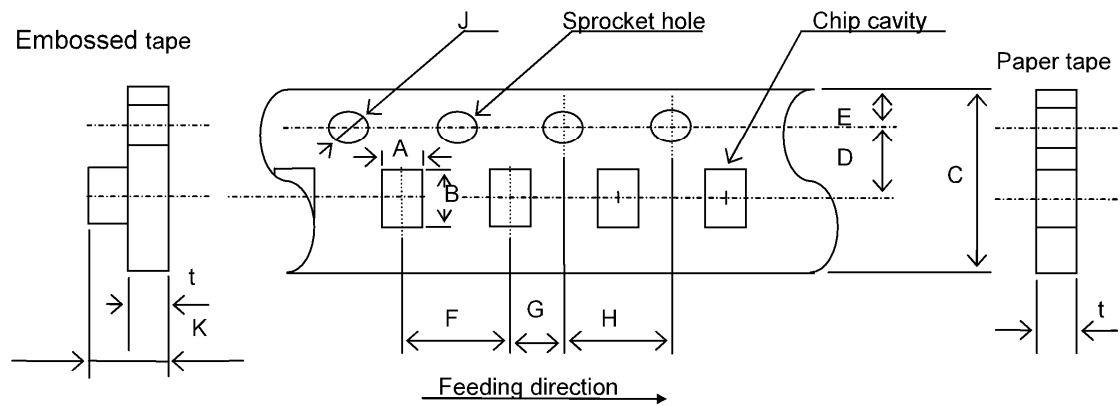

Dimensions of Reel [Unit: mm]

Type	A	B	C	D	E	W	t	R
107 to 325	$\phi 178 \pm 2.0$	$\phi 50 \text{ min.}$	$\phi 13.0 \pm 0.2$	$\phi 21.0 \pm 0.8$	2.0 ± 0.5	10.0 ± 1.5	2.5 max.	1.0
325※, 432	$\phi 178 \pm 2.0$	$\phi 50 \text{ min.}$	$\phi 13.0 \pm 0.2$	$\phi 21.0 \pm 0.8$	2.0 ± 0.5	14.0 ± 1.5	2.5 max.	1.0

※12mm width tape

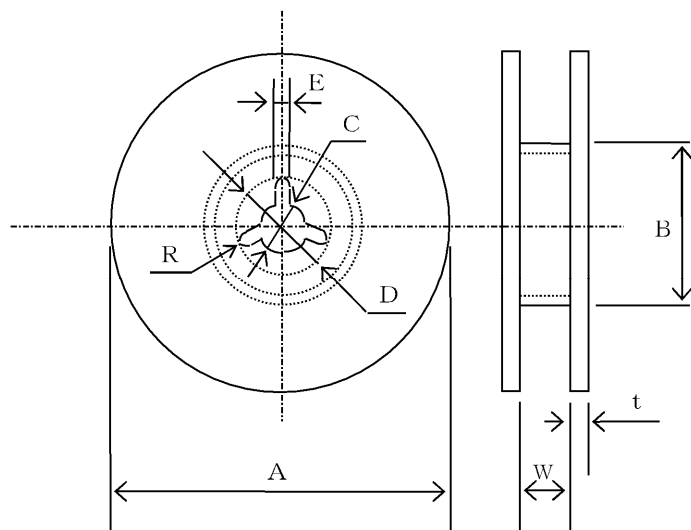

- 1) Taping shall be right-sided wound. Sprocket hole shall be on the right side against the pull-out direction.
- 2) Either the width side (W) or the thickness side (t) of the products below faces up at random when the products are inserted in the chip cavities:

107 (0603) type with 0.8 mm thickness, 212 (0805) type with 1.25 mm thickness,
 316 (1206) type with 1.6 mm thickness, 325 (1210) type with 2.5 mm thickness

- 3) There shall be blank spaces in each reel tape as shown in the following figure.

- Leader part 400 mm min.
- Leader part (Blank part) 100 mm min.
- Trailer (Blank part) 160 mm min.

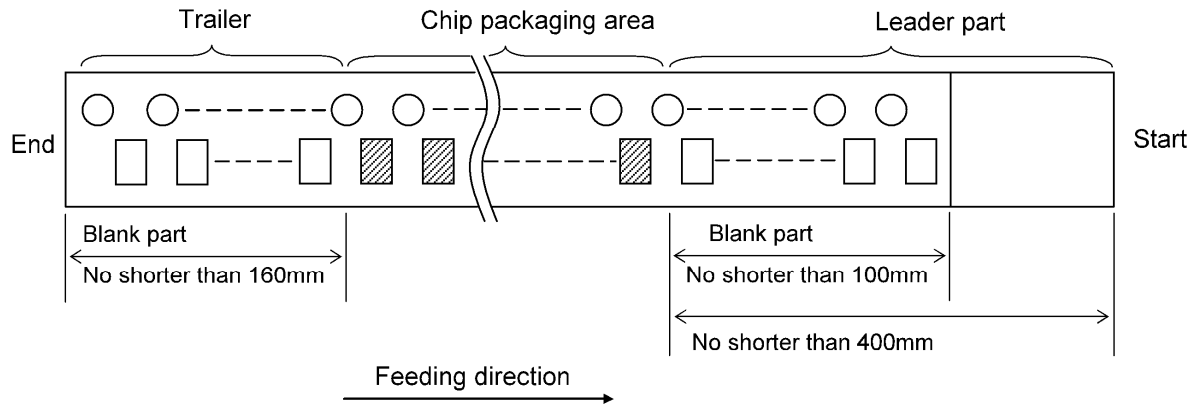

- 4) Neither top/bottom tapes of paper tape nor top tape of embossed tape shall cover sprocket holes.
- 5) There shall be no seam on paper tape or embossed tape.
- 6) Tensile strength of the tape shall be 5N (0.51 kgf) or over.
- 7) The number of the chip missing from tape reel shall be one (1) piece at a maximum per reel.
- 8) The number of packaged chips per reel is shown in the table below.
- 9) Label indicating part No., quantity and control No. shall be attached to the outside of each reel.
- 10) Peeling strength of top tape shall be 0.1 to 0.7N (10.2 to 71.4 gf) when top tape is peeled from carrier tape at an angle of 0 to 20 degrees.

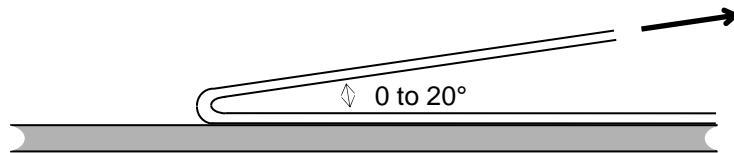

Quantity of taping package

Type	Thickness [Unit: mm] (Thickness code)	Quantity (pcs/reel)	Carrier tape
107	0.45 (K)	4,000	Paper
	0.80 (A)		Embossed (Plastic)
212	0.85 (D)	3,000	Paper
	1.25 (G)		Embossed (Plastic)
316	0.85 (D)	4,000	Paper
	1.15 (F)	3,000	Embossed (Plastic)
	1.25 (G)		
	1.60 (L)	2,000	

Type	Thickness [Unit: mm] (Thickness code)	Quantity (pcs/reel)	Carrier tape
325	0.85 (D)	2,000	Embossed (Plastic)
	1.15 (F)		
	1.50 (H)		
	1.90 (N)		
	1.9+0.1/-0.2 (Y)		
	2.50 (M)	1,000	
432	2.50 (M)	500	

※For 325 size with 2.50 (M)-thickness products, Packaging code *P/*PR means 1000 pieces per reel and *T/*TR means 500 pieces per reel.

■ PRECAUTIONS

1. Circuit Design

Precautions	<ul style="list-style-type: none">◆ Verification of operating environment, electrical rating and performance<ol style="list-style-type: none">1. A malfunction of equipment in fields such as medical, aerospace, nuclear control, etc. may cause serious harm to human life or have severe social ramifications. Therefore, any capacitors to be used in such equipment may require higher safety and reliability, and shall be clearly differentiated from them used in general purpose applications.◆ Operating Voltage (Verification of Rated voltage)<ol style="list-style-type: none">1. The operating voltage for capacitors must always be their rated voltage or less. If an AC voltage is loaded on a DC voltage, the sum of the two peak voltages shall be the rated voltage or less. For a circuit where an AC or a pulse voltage may be used, the sum of their peak voltages shall also be the rated voltage or less.2. Even if an applied voltage is the rated voltage or less reliability of capacitors may be deteriorated in case that either a high frequency AC voltage or a pulse voltage having rapid rise time is used in a circuit.
-------------	--

2. PCB Design

Precautions	<ul style="list-style-type: none">◆ Pattern configurations (Design of Land-patterns)<ol style="list-style-type: none">1. When capacitors are mounted on PCBs, the amount of solder used (size of fillet) can directly affect the capacitor performance. Therefore, the following items must be carefully considered in the design of land patterns:<ol style="list-style-type: none">(1) Excessive solder applied can cause mechanical stresses which lead to chip breaking or cracking. Therefore, please consider appropriate land-patterns for proper amount of solder.(2) When more than one component are jointly soldered onto the same land, each component's soldering point shall be separated by solder-resist.◆ Pattern configurations (Capacitor layout on PCBs)<p>After capacitors are mounted on boards, they can be subjected to mechanical stresses in subsequent manufacturing processes (PCB cutting, board inspection, mounting of additional parts, assembly into the chassis, wave soldering of the boards, etc.). For this reason, land pattern configurations and positions of capacitors shall be carefully considered to minimize stresses</p>
-------------	---

◆Pattern configurations (Design of Land-patterns)

The following diagrams and tables show some examples of recommended land patterns to prevent excessive solder amounts.

(1) Recommended land dimensions for typical chip capacitors

● Multilayer Ceramic Capacitors : Recommended land dimensions

(unit: mm)

Wave-soldering

Type	107	212	316	325	
Size	L	1.6	2.0	3.2	3.2
	W	0.8	1.25	1.6	2.5
A	0.8 to 1.0	1.0 to 1.4	1.8 to 2.5	1.8 to 2.5	
B	0.5 to 0.8	0.8 to 1.5	0.8 to 1.7	0.8 to 1.7	
C	0.6 to 0.8	0.9 to 1.2	1.2 to 1.6	1.8 to 2.5	

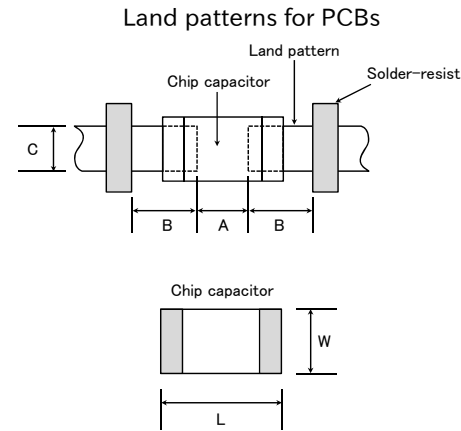

Reflow-soldering

Type	021	042	063	105	107	212	316	325	432
Size	L	0.25	0.4	1.0	1.6	2.0	3.2	3.2	4.5
	W	0.125	0.2	0.3	0.5	0.8	1.25	1.6	2.5
A	0.095~ 0.135	0.15~ 0.25	0.20~ 0.30	0.45~ 0.55	0.8~1.0	0.8~1.2	1.8~2.5	1.8~2.5	2.5~3.5
B	0.085~ 0.125	0.15~ 0.20	0.20~ 0.30	0.40~ 0.50	0.6~0.8	0.8~1.2	1.0~1.5	1.0~1.5	1.5~1.8
C	0.110~ 0.150	0.15~ 0.30	0.25~ 0.40	0.45~ 0.55	0.6~0.8	0.9~1.6	1.2~2.0	1.8~3.2	2.3~3.5

Note: Recommended land size might be different according to the allowance of the size of the product.

● LWDC: Recommended land dimensions for reflow-soldering

(unit: mm)

Type	105	107	212	
Size	L	0.52	0.8	1.25
	W	1.0	1.6	2.0
A	0.18~ 0.22	0.25~0.3	0.5~0.7	
B	0.2~0.25	0.3~0.4	0.4~0.5	
C	0.9~1.1	1.5~1.7	1.9~2.1	

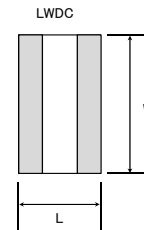

Technical
considerati
ons

(2) Examples of good and bad solder application

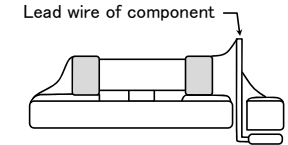
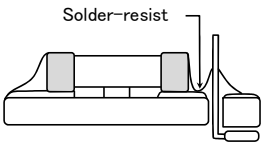
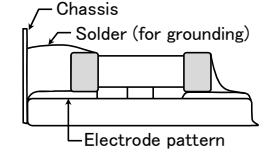
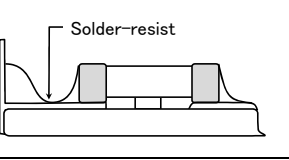
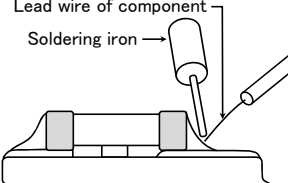
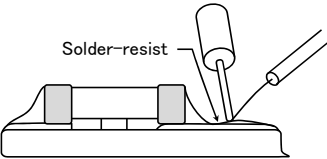
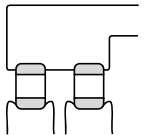
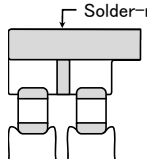
Item	Not recommended	Recommended
Mixed mounting of SMD and leaded components		
Component placement close to the chassis		
Hand-soldering of leaded components near mounted components		
Horizontal component placement		

◆Pattern configurations (Capacitor layout on PCBs)

1-1. The following is examples of good and bad capacitor layouts ; capacitors shall be located to minimize any possible mechanical stresses from board warp or deflection.

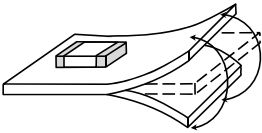
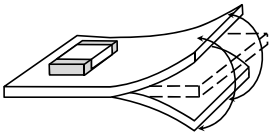
Items	Not recommended	Recommended
Deflection of board		 <p data-bbox="1137 225 1397 384">Place the product at a right angle to the direction of the anticipated mechanical stress.</p>

1-2. The amount of mechanical stresses given will vary depending on capacitor layout. Please refer to diagram below.

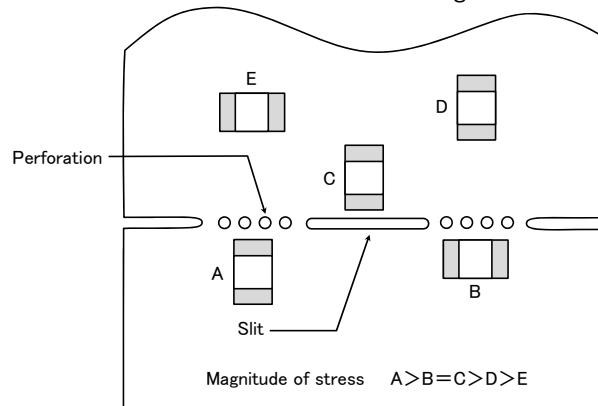

1-3. When PCB is split, the amount of mechanical stress on the capacitors can vary according to the method used. The following methods are listed in order from least stressful to most stressful: push-back, slit, V-grooving, and perforation. Thus, please consider the PCB, split methods as well as chip location.

3. Mounting

Precautions

- ◆ Adjustment of mounting machine
 1. When capacitors are mounted on PCB, excessive impact load shall not be imposed on them.
 2. Maintenance and inspection of mounting machines shall be conducted periodically.
- ◆ Selection of Adhesives
 1. When chips are attached on PCBs with adhesives prior to soldering, it may cause capacitor characteristics degradation unless the following factors are appropriately checked : size of land patterns, type of adhesive, amount applied, hardening temperature and hardening period. Therefore, please contact us for further information.

Technical considerations

- ◆ Adjustment of mounting machine
 1. When the bottom dead center of a pick-up nozzle is too low, excessive force is imposed on capacitors and causes damages. To avoid this, the following points shall be considerable.
 - (1) The bottom dead center of the pick-up nozzle shall be adjusted to the surface level of PCB without the board deflection.
 - (2) The pressure of nozzle shall be adjusted between 1 and 3 N static loads.
 - (3) To reduce the amount of deflection of the board caused by impact of the pick-up nozzle, supporting pins or back-up pins shall be used on the other side of the PCB. The following diagrams show some typical examples of good and bad pick-up nozzle placement:

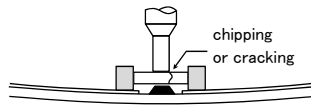
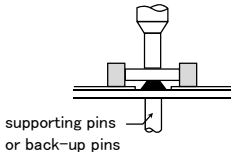
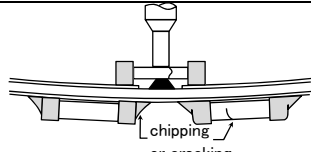
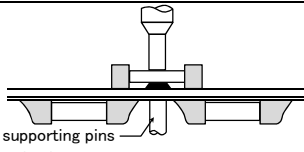
Item	Improper method	Proper method
Single-sided mounting		
Double-sided mounting		

2. As the alignment pin is worn out, adjustment of the nozzle height can cause chipping or cracking of capacitors because of mechanical impact on the capacitors. To avoid this, the monitoring of the width between the alignment pins in the stopped position, maintenance, check and replacement of the pin shall be conducted periodically.

- ◆ Selection of Adhesives

Some adhesives may cause IR deterioration. The different shrinkage percentage of between the adhesive and the capacitors may result in stresses on the capacitors and lead to cracking. Moreover, too little or too much adhesive applied to the board may adversely affect components. Therefore, the following precautions shall be noted in the application of adhesives.

- (1) Required adhesive characteristics
- The adhesive shall be strong enough to hold parts on the board during the mounting & solder process.
 - The adhesive shall have sufficient strength at high temperatures.
 - The adhesive shall have good coating and thickness consistency.
 - The adhesive shall be used during its prescribed shelf life.
 - The adhesive shall harden rapidly.
 - The adhesive shall have corrosion resistance.
 - The adhesive shall have excellent insulation characteristics.
 - The adhesive shall have no emission of toxic gasses and no effect on the human body.

(2) The recommended amount of adhesives is as follows;

[Recommended condition]

Figure	212/316 case sizes as examples
a	0.3mm min
b	100 to 120 μ m
c	Adhesives shall not contact land

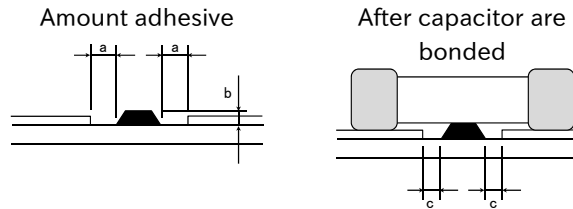

4. Soldering

Precautions

◆ Selection of Flux

Since flux may have a significant effect on the performance of capacitors, it is necessary to verify the following conditions prior to use;

- Flux used shall be less than or equal to 0.1 wt% (in Cl equivalent) of halogenated content. Flux having a strong acidity content shall not be applied.
- When shall capacitors are soldered on boards, the amount of flux applied shall be controlled at the optimum level.
- When water-soluble flux is used, special care shall be taken to properly clean the boards.

◆ Soldering

Temperature, time, amount of solder, etc. shall be set in accordance with their recommended conditions.

Sn-Zn solder paste can adversely affect MLCC reliability.

Please contact us prior to usage of Sn-Zn solder.

Technical considerations

◆ Selection of Flux

- 1-1. When too much halogenated substance (Chlorine, etc.) content is used to activate flux, or highly acidic flux is used, it may lead to corrosion of terminal electrodes or degradation of insulation resistance on the surfaces of the capacitors.
- 1-2. Flux is used to increase solderability in wave soldering. However if too much flux is applied, a large amount of flux gas may be emitted and may adversely affect the solderability. To minimize the amount of flux applied, it is recommended to use a flux-bubbling system.
- 1-3. Since the residue of water-soluble flux is easily dissolved in moisture in the air, the residues on the surfaces of capacitors in high humidity conditions may cause a degradation of insulation resistance and reliability of the capacitors. Therefore, the cleaning methods and the capability of the machines used shall also be considered carefully when water-soluble flux is used.

◆Soldering

- Ceramic chip capacitors are susceptible to thermal shock when exposed to rapid or concentrated heating or rapid cooling.
- Therefore, the soldering must be conducted with great care so as to prevent malfunction of the components due to excessive thermal shock.
- Preheating : Capacitors shall be preheated sufficiently, and the temperature difference between the capacitors and solder shall be within 130°C.
- Cooling : The temperature difference between the capacitors and cleaning process shall not be greater than 100°C.

[Reflow soldering]

[Recommended conditions for eutectic soldering]

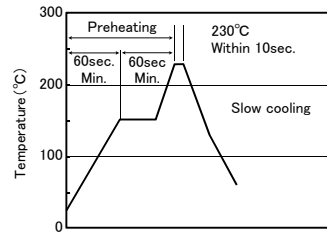

[Recommended condition for Pb-free soldering]

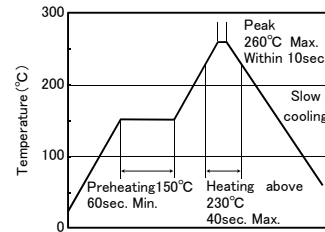

Caution

- ①The ideal condition is to have solder mass (fillet) controlled to 1/2 to 1/3 of the thickness of a capacitor.
- ②Because excessive dwell times can adversely affect solderability, soldering duration shall be kept as close to recommended times as possible. soldering for 2 times.

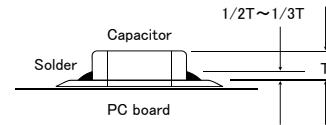

[Wave soldering]

[Recommended conditions for eutectic soldering]

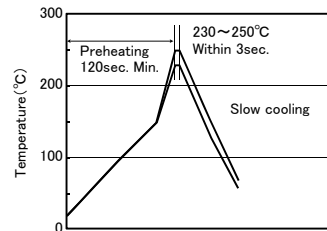

[Recommended condition for Pb-free soldering]

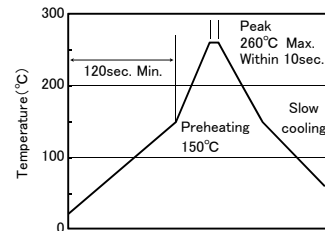

Caution

- ①Wave soldering must not be applied to capacitors designated as for reflow soldering only. soldering for 1 times.

[Hand soldering]
 [Recommended conditions for eutectic soldering]

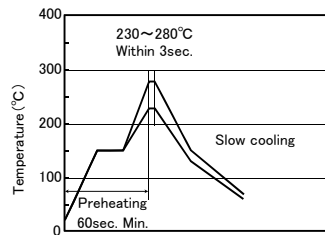

[Recommended condition for Pb-free soldering]

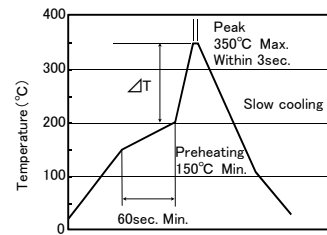

	ΔT
316type or less	$\Delta T \leq 150^{\circ}\text{C}$

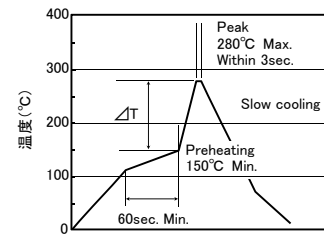

	ΔT
325type or more	$\Delta T \leq 130^{\circ}\text{C}$

Caution

- ① Use a 20W soldering iron with a maximum tip diameter of 1.0 mm.
- ② The soldering iron shall not directly touch capacitors. soldering for 1 times.

5. Cleaning

Precautions

- ◆Cleaning conditions
1. When PCBs are cleaned after capacitors mounting, please select the appropriate cleaning solution in accordance with the intended use of the cleaning. (e.g. to remove soldering flux or other materials from the production process.)
 2. Cleaning condition shall be determined after it is verified by using actual cleaning machine that the cleaning process does not affect capacitor's characteristics.

Technical considerations

1. The use of inappropriate cleaning solutions can cause foreign substances such as flux residue to adhere to capacitors or deteriorate their outer coating, resulting in a degradation of the capacitor's electrical properties (especially insulation resistance).
2. Inappropriate cleaning conditions (insufficient or excessive cleaning) may adversely affect the performance of the capacitors.
 In the case of ultrasonic cleaning, too much power output can cause excessive vibration of PCBs which may lead to the cracking of capacitors or the soldered portion, or decrease the terminal electrodes' strength. Therefore, the following conditions shall be carefully checked;
 Ultrasonic output : 20 W/ℓ or less Ultrasonic frequency : 40 kHz or less
 Ultrasonic washing period : 5 min. or less

6. Resin coating and mold

Precautions

1. With some type of resins, decomposition gas or chemical reaction vapor may remain inside the resin during the hardening period or while left under normal storage conditions resulting in the deterioration of the capacitor's performance.
2. When a resin's hardening temperature is higher than capacitor's operating temperature, the stresses generated by the excessive heat may lead to damage or destruction of capacitors.
 The use of such resins, molding materials etc. is not recommended.

7. Handling

Precautions	<ul style="list-style-type: none">◆Splitting of PCB<ol style="list-style-type: none">1. When PCBs are split after components mounting, care shall be taken so as not to give any stresses of deflection or twisting to the board.2. Board separation shall not be done manually, but by using the appropriate devices.◆Mechanical considerations<p>Be careful not to subject capacitors to excessive mechanical shocks.</p><ol style="list-style-type: none">(1) If ceramic capacitors are dropped onto a floor or a hard surface, they shall not be used.(2) Please be careful that the mounted components do not come in contact with or bump against other boards or components.
-------------	--

8. Storage conditions

Precautions	<ul style="list-style-type: none">◆Storage<ol style="list-style-type: none">1. To maintain the solderability of terminal electrodes and to keep packaging materials in good condition, care must be taken to control temperature and humidity in the storage area. Humidity should especially be kept as low as possible.<ul style="list-style-type: none">·Recommended conditions Ambient temperature : Below 30°C Humidity : Below 70% RHThe ambient temperature must be kept below 40°C. Even under ideal storage conditions, solderability of capacitor is deteriorated as time passes, so capacitors shall be used within 6 months from the time of delivery.·Ceramic chip capacitors shall be kept where no chlorine or sulfur exists in the air.2. The capacitance values of high dielectric constant capacitors will gradually decrease with the passage of time, so care shall be taken to design circuits. Even if capacitance value decreases as time passes, it will get back to the initial value by a heat treatment at 150°C for 1 hour.
Technical considerations	If capacitors are stored in a high temperature and humidity environment, it might rapidly cause poor solderability due to terminal oxidation and quality loss of taping/packaging materials. For this reason, capacitors shall be used within 6 months from the time of delivery. If exceeding the above period, please check solderability before using the capacitors.

※RCR-2335 (Safety Application Guide for fixed ceramic capacitors for use in electronic equipment) is published by JEITA.

Please check the guide regarding precautions for deflection test, soldering by spot heat, and so on.