

---

---

## USB Firmware Memory

---

---

### Features

- Firmware Memory Companion for the USB491X Family of USB Controllers
- Targeted for USB 2.0 High-Speed Infotainment Applications Including:
  - Integration with head unit systems
  - First, second, and third row USB media hubs
- Memory Size:
  - 512 KByte (4 Mbit)
- Single Voltage Read and Write Operations:
  - 2.7-3.6V
- Serial Interface Architecture:
  - SPI Compatible: Mode 0 and Mode 3
- High Speed Clock Frequency:
  - 40 MHz
- READ Support:
  - Fast-Read Dual-Output
  - Fast-Read Single I/O
- Superior Reliability:
  - Endurance: 100,000 Cycles
  - Greater than 20 years Data Retention
- Ultra-Low Power Consumption:
  - Active Read Current: 5 mA (typical)
  - Standby Current: 5  $\mu$ A (typical)
  - Power-down Mode Standby Current: 3  $\mu$ A (typical)
- Flexible Erase Capability:
  - Uniform 4 KByte sectors
  - Uniform 64 KByte overlay blocks
- Page Program Mode:
  - 256 Bytes/Page
- Fast Erase and Page-Program:
  - Chip Erase Time: 250 ms (typical)
  - Sector Erase Time: 40 ms (typical)
  - Block Erase Time: 80 ms (typical)
  - Page-Program Time: 4 ms/ 256 bytes (typical)
- End-of-Write Detection:
  - Software polling the BUSY bit in Status Register
- Hold Pin (HOLD#):
  - Suspend a serial sequence without deselecting the device
- Write Protection (WP#):
  - Enables/Disables the Lock-Down function of the status register

- Software Write Protection:
  - Write protection through Block-Protection bits in status register
- Temperature Range:
  - Automotive Grade 1: -40°C to 125°C
  - Automotive Grade 2: -40°C to 105°C
  - Automotive Grade 3: -40°C to 85°C
- Packages Available:
  - 8-lead SOIC (150 mils)
  - 8-contact USON (2x3 mm)
- All Devices are RoHS Compliant

### Product Description

USBF4100, a USB Firmware memory chip, is a companion to the Microchip Automotive USB Smart Hub devices: USB491X. Factory pre-programming is available for custom firmware and configurations. The USBF4100 memory function assures proper functionality, providing for decreased development time and engineering resource, and overall faster time to market.

The USB Firmware memory family features a four-wire, SPI-compatible interface that allows for a low pin count package, which occupies less board space and ultimately lowers total system costs. It is manufactured with proprietary, high-performance CMOS SuperFlash technology. The split-gate cell design and thick-oxide tunneling injector attain better reliability and manufacturability compared with alternate approaches ideal for applications requiring high quality and reliability.

USBF4100 is offered in 8-lead SOIC and 8-contact USON. See [Figure 1-1](#) for the pin assignments.

## TO OUR VALUED CUSTOMERS

It is our intention to provide our valued customers with the best documentation possible to ensure successful use of your Microchip products. To this end, we will continue to improve our publications to better suit your needs. Our publications will be refined and enhanced as new volumes and updates are introduced.

If you have any questions or comments regarding this publication, please contact the Marketing Communications Department via E-mail at [docerrors@microchip.com](mailto:docerrors@microchip.com). We welcome your feedback.

### Most Current Data Sheet

To obtain the most up-to-date version of this data sheet, please register at our Worldwide Website at:

<http://www.microchip.com>

You can determine the version of a data sheet by examining its literature number found on the bottom outside corner of any page. The last character of the literature number is the version number, (e.g., DS30000000A is version A of document DS30000000).

### Errata

An errata sheet, describing minor operational differences from the data sheet and recommended workarounds, may exist for current devices. As device/documentation issues become known to us, we will publish an errata sheet. The errata will specify the revision of silicon and revision of document to which it applies.

To determine if an errata sheet exists for a particular device, please check with one of the following:

- Microchip's Worldwide Website; <http://www.microchip.com>
- Your local Microchip sales office (see last page)

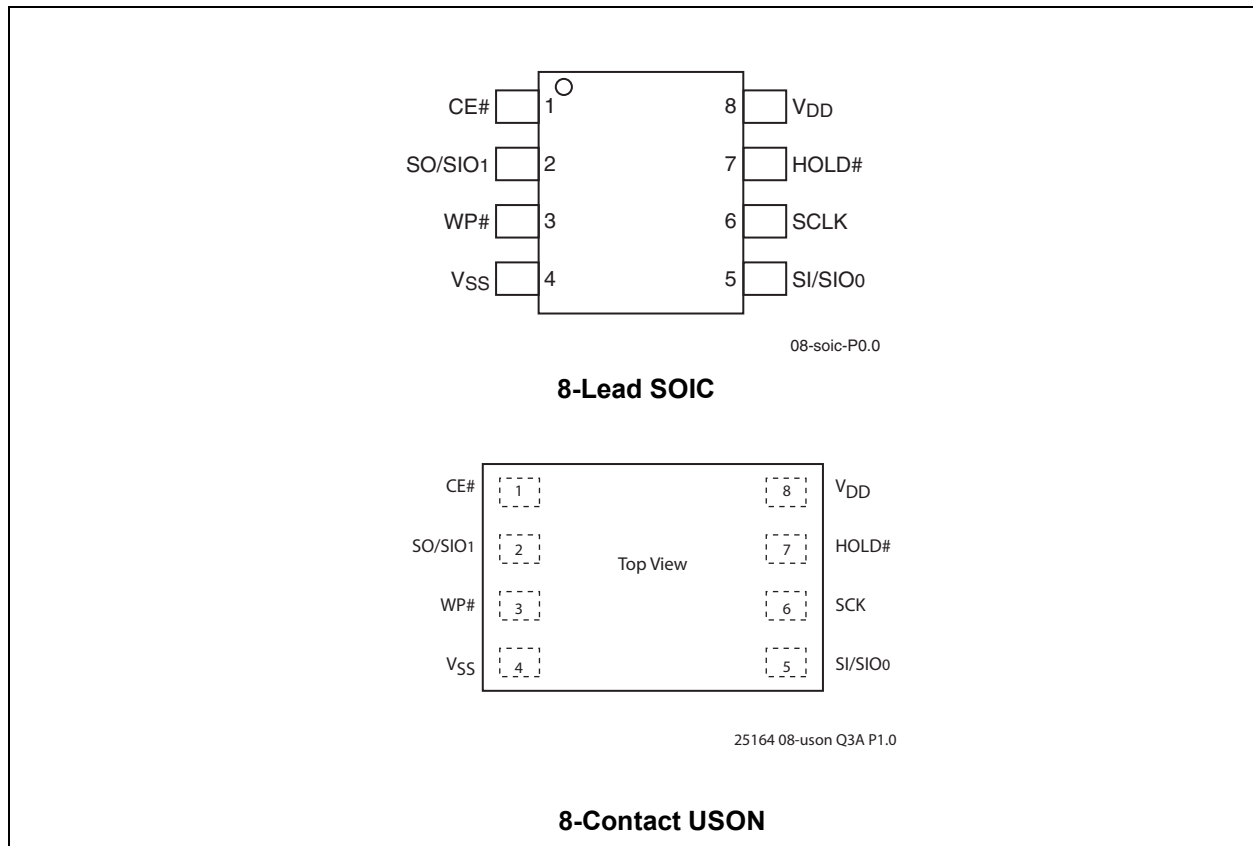
When contacting a sales office, please specify which device, revision of silicon and data sheet (include literature number) you are using.

### Customer Notification System

Register on our website at [www.microchip.com](http://www.microchip.com) to receive the most current information on all of our products.

## 1.0 PIN ASSIGNMENTS

**FIGURE 1-1: PIN ASSIGNMENTS**



**TABLE 1-1: PIN DESCRIPTION**

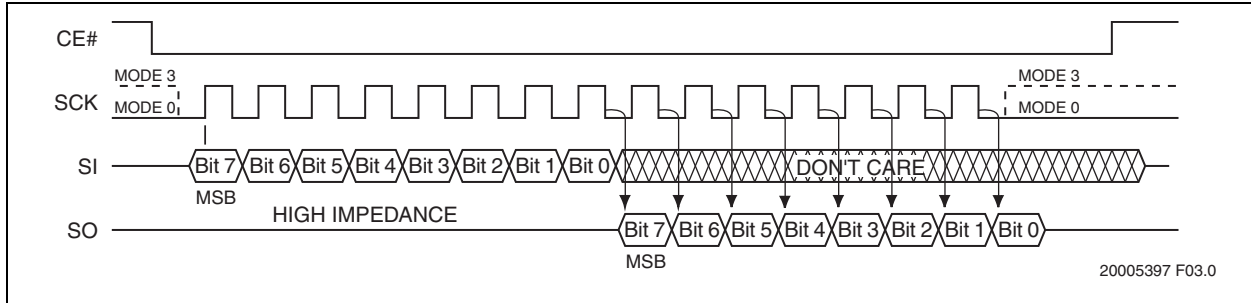
Symbol	Pin Name	Functions
SCK	Serial Clock	To provide the input/output timing of the serial interface. Commands, addresses, or input data are latched on the rising edge of the clock input, while output data is shifted out on the falling edge of the clock input.
SI	Serial Data Input	To transfer commands, addresses, or data serially into the device. Inputs are latched on the rising edge of the serial clock.
SO	Serial Data Output	To transfer data serially out of the device. Data is shifted out on the falling edge of the serial clock.
SIO <sub>[0:1]</sub>	Serial Data Input/Output for Dual I/O Mode	To transfer commands, addresses, or data serially into the device, or data out of the device. Inputs are latched on the rising edge of the serial clock. Data is shifted out on the falling edge of the serial clock. These pins are used in Dual I/O mode
CE#	Chip Enable	The device is enabled by a high to low transition on CE#. CE# must remain low for the duration of any command sequence. The device is deselected and placed in Standby mode when CE# is high.
WP#	Write-Protect	The Write-Protect (WP#) pin is used to enable/disable BPL bit in the STATUS register.
HOLD#	Hold	To temporarily stop serial communication with USB Firmware memory while device is selected.
V <sub>DD</sub>	Power Supply	To provide power supply voltage: 2.7-3.6V
V <sub>SS</sub>	Ground	

## 2.0 DEVICE OPERATION

USBF4100 is accessed through the SPI (Serial Peripheral Interface) bus compatible protocol. The SPI bus consist of four control lines: Chip Enable (CE#) is used to select the device, and data is accessed through the Serial Data Input (SI), Serial Data Output (SO), and Serial Clock (SCK).

The USBF4100 supports both Mode 0 (0,0) and Mode 3 (1,1) of SPI bus operations. The difference between the two modes, as shown in Figure 2-1, is the state of the SCK signal when the bus master is in Standby mode and no data is being transferred. The SCK signal is low for Mode 0 and SCK signal is high for Mode 3. For both modes, the Serial Data In (SI) is sampled at the rising edge of the SCK clock signal and the Serial Data Output (SO) is driven after the falling edge of the SCK clock signal.

**FIGURE 2-1: SPI PROTOCOL**



## 3.0 INSTRUCTIONS

Instructions are used to read, write (Erase and Program), and configure the USBF4100 devices. The instruction bus cycles are 8 bits each for commands (Op Code), data, and addresses. The Write-Enable (WREN) instruction must be executed prior to Sector Erase, Block Erase, Page-Program, Write-Status-Register, or Chip Erase instructions. The complete instructions are provided in Table 3-1. All instructions are synchronized off a high-to-low transition of CE#. Inputs will be accepted on the rising edge of SCK starting with

the Most Significant bit. CE# must be driven low before an instruction is entered and must be driven high after the last bit of the instruction has been shifted in (except for Read, Read-ID, and Read-Status-Register instructions). Any low-to-high transition on CE#, before receiving the last bit of an instruction bus cycle, will terminate the instruction in progress and return the device to Standby mode. Instruction commands (Op Code), addresses, and data are all input from the Most Significant bit (MSB) first.

**TABLE 3-1: DEVICE OPERATION INSTRUCTIONS**

Instruction	Description	Op Code Cycle <sup>1</sup>	Address Cycle(s) <sup>2</sup>	Dummy Cycle(s)	Data Cycle(s)	Maximum Frequency
Read	Read Memory	0000 0011b (03H)	3	0	1 to ∞	25 MHz
High-Speed Read	Read Memory at Higher Speed	0000 1011b (0BH)	3	1	1 to ∞	40 MHz
Fast-Read Dual-Output	Read Memory with Dual Output	0011 1011b (3BH)	3	1 <sup>3</sup>	1 to ∞ <sup>3</sup>	
Fast-Read Dual I/O	Read Memory with Dual Address Input and Data Output	1011 1011b (BBH)	3 <sup>3</sup>	1 <sup>3</sup>	1 to ∞ <sup>3</sup>	
4 KByte Sector Erase <sup>4</sup>	Erase 4 KByte of memory array	0010 0000b (20H) 1101 0111b (D7H)	3	0	0	
64 KByte Block Erase <sup>5</sup>	Erase 64 KByte block of memory array	1101 1000b (D8H)	3	0	0	
Chip Erase	Erase Full Memory Array	0110 0000b (60H) or 1100 0111b (C7H)	0	0	0	
Page-Program	To program up to 256 Bytes	0000 0010b (02H)	3	0	1 to 256	
RDSR <sup>6</sup>	Read-Status-Register	0000 0101b (05H)	0	0	1 to ∞	
WRSR	Write-Status-Register	0000 0001b (01H)	0	0	1	
WREN	Write-Enable	0000 0110b (06H)	0	0	0	
WRDI	Write-Disable	0000 0100b (04H)	0	0	0	
RDID <sup>7, 8</sup>	Read-ID	1010 1011b (ABH)	3	0	1 to ∞	
JEDEC-ID	JEDEC ID Read	1001 1111b (9FH)	0	0	4 to ∞	
DPD	Deep Power-Down Mode	1011 1001b (B9H)	0	0	0	
RDPD <sup>8</sup>	Release from Deep Power-Down or Read ID	1010 1011b (ABH)	0	0	0	

1. One bus cycle is eight clock periods.
2. Address bits above the Most Significant bit of each density can be V<sub>IL</sub> or V<sub>IH</sub>.
3. One bus cycle is four clock periods in Dual Operation
4. 4 KByte Sector Erase addresses: use A<sub>MS</sub>-A<sub>12</sub>, remaining addresses are don't care but must be set either at V<sub>IL</sub> or V<sub>IH</sub>.
5. 64 KByte Block Erase addresses: use A<sub>MS</sub>-A<sub>16</sub>, remaining addresses are don't care but must be set either at V<sub>IL</sub> or V<sub>IH</sub>.
6. The Read-Status-Register is continuous with ongoing clock cycles until terminated by a low to high transition on CE#.
7. Device ID = 6EH is read after three dummy address bytes. The Device ID output stream is continuous until terminated by a low-to-high transition on CE#.
8. The instructions Release from Deep Power-Down and Read-ID are similar instructions (ABH). Executing Read-ID requires the ABH instruction, followed by 24 dummy address bits to retrieve the Device ID. Release from Deep Power-Down only requires the instruction ABH. JEDEC-ID data = 62H 06H 13H 00H.

## 4.0 ELECTRICAL SPECIFICATIONS

**Absolute Maximum Stress Ratings** (Applied conditions greater than those listed under “Absolute Maximum Stress Ratings” may cause permanent damage to the device. This is a stress rating only and functional operation of the device at these conditions or conditions greater than those defined in the operational sections of this data sheet is not implied. Exposure to absolute maximum stress rating conditions may affect device reliability.)

Temperature Under Bias .....	-55°C to +125°C
Storage Temperature .....	-55°C to +150°C
D. C. Voltage on Any Pin to Ground Potential .....	-0.5V to $V_{DD}+0.5V$
Transient Voltage (<20 ns) on Any Pin to Ground Potential .....	-2.0V to $V_{DD}+2.0V$
Package Power Dissipation Capability ( $T_A = 25^\circ C$ ) .....	1.0W
Surface Mount Solder Reflow Temperature .....	260°C for 10 seconds
Output Short Circuit Current <sup>1</sup> .....	50 mA

1. Output shorted for no more than one second. No more than one output shorted at a time.

**TABLE 4-1: OPERATING RANGE**

Range	Ambient Temp	$V_{DD}$
Automotive Grade 1	-40°C to +125°C	2.7 - 3.6V
Automotive Grade 2	-40°C to +105°C	2.7 - 3.6V
Automotive Grade 3	-40°C to +85°C	2.7 - 3.6V

**TABLE 4-2: AC CONDITIONS OF TEST**

Input Rise/Fall Time	Output Load
5ns	$C_L = 30 \text{ pF}$

## 4.1 Power-Up Specifications

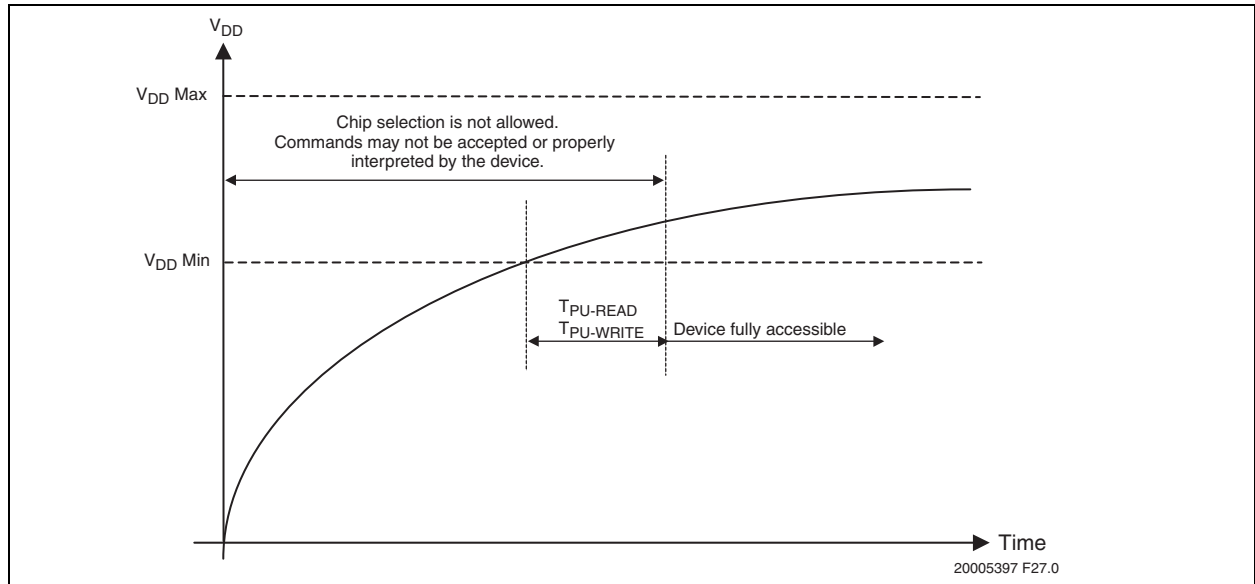
All functionalities and DC specifications are specified for a  $V_{DD}$  ramp rate of greater than 1V per 100 ms (0V to 3.3V in less than 330 ms). See [Table 4-3](#) and [Figure 4-2](#) for more information.

**TABLE 4-3: RECOMMENDED SYSTEM POWER-UP TIMINGS**

Symbol	Parameter	Minimum	Units
$T_{PU-READ}^1$	$V_{DD}$ Min to Read Operation	100	$\mu s$
$T_{PU-WRITE}^1$	$V_{DD}$ Min to Write Operation	100	$\mu s$

1. This parameter is measured only for initial qualification and after a design or process change that could affect this parameter.

**FIGURE 4-1: POWER-UP TIMING DIAGRAM**

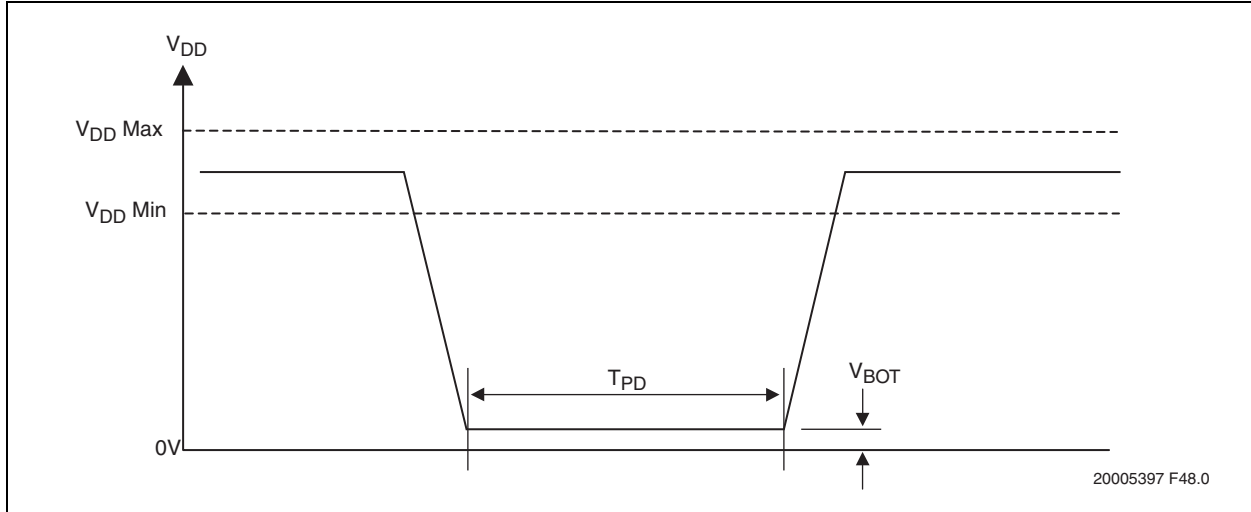


## 4.2 Hardware Data Protection

USBF4100 provides a power-up reset function. To ensure that the power reset circuit will operate correctly, the device must meet the conditions shown in

Figure 4-2 and Table 4-4. Microchip does not guarantee the data in the event of an instantaneous power failure that occurs during a Write operation.

**FIGURE 4-2: POWER-DOWN TIMING DIAGRAM**



**TABLE 4-4: RECOMMENDED SYSTEM POWER-DOWN TIMINGS**

Symbol	Parameter	Min	Max	Units
T <sub>PD</sub>	Power-down time	10		ms
V <sub>BOT</sub>	Power-down voltage		0.2	V

## 4.3 Software Data Protection

USBF4100 prevents unintentional operations by not recognizing commands under the following conditions:

- After inputting a Write command, if the rising CE# edge timing is not in a bus cycle (8 CLK units of SCK)
- When the Page-Program data is not in 1-byte increments
- If the Write Status Register instruction is input for two bus cycles or more.

## 4.4 Decoupling Capacitor

A 0.1μF ceramic capacitor must be provided for each device and connected between V<sub>DD</sub> and V<sub>SS</sub> to ensure that the device will operate correctly.



## 4.5 DC Characteristics

**TABLE 4-5: DC OPERATING CHARACTERISTICS**

Symbol	Parameter	Limits				Test Conditions
		Min	Typ <sup>1</sup>	Max	Units	
I <sub>DDR</sub>	Read Current			6	mA	CE#=0.1 V <sub>DD</sub> /0.9 V <sub>DD</sub> @25 MHz, SO=open; Single I/O
I <sub>DDR2</sub>	Read Current			10	mA	CE#=0.1 V <sub>DD</sub> /0.9V <sub>DD</sub> @40 MHz, SO=open
I <sub>DDR3</sub>	Read Current			12	mA	CE#=0.1 V <sub>DD</sub> /0.9V <sub>DD</sub> @40 MHz, SO=open; Dual I/O;
I <sub>DDW</sub>	Program and Erase Current			15	mA	CE#=V <sub>DD</sub>
I <sub>SB</sub>	Standby Current			50	μA	CE#=V <sub>DD</sub> , V <sub>IN</sub> =V <sub>DD</sub> or V <sub>SS</sub>
I <sub>DPD</sub>	Deep Power-Down			10	μA	CE#=V <sub>DD</sub> , V <sub>IN</sub> =V <sub>DD</sub> or V <sub>SS</sub>
I <sub>LI</sub>	Input Leakage Current			2	μA	V <sub>IN</sub> =GND to V <sub>DD</sub> , V <sub>DD</sub> =V <sub>DD</sub> Max
I <sub>LO</sub>	Output Leakage Current			2	μA	V <sub>OUT</sub> =GND to V <sub>DD</sub> , V <sub>DD</sub> =V <sub>DD</sub> Max
V <sub>IL</sub>	Input Low Voltage	-0.3		0.3	V	V <sub>DD</sub> =V <sub>DD</sub> Min
V <sub>IH</sub>	Input High Voltage	0.7 V <sub>DD</sub>		V <sub>DD</sub> +0.3	V	V <sub>DD</sub> =V <sub>DD</sub> Max
V <sub>OL</sub>	Output Low Voltage			0.2	V	I <sub>OL</sub> =100 μA, V <sub>DD</sub> =V <sub>DD</sub> Min
V <sub>OH</sub>	Output High Voltage	V <sub>DD</sub> -0.2			V	I <sub>OH</sub> =-100 μA, V <sub>DD</sub> =V <sub>DD</sub> Min

1. Value characterized, not fully tested in production.

**TABLE 4-6: CAPACITANCE (T<sub>A</sub> = 25°C, F=1 MHz, OTHER PINS OPEN)**

Parameter	Description	Test Condition	Maximum
C <sub>OUT</sub> <sup>1</sup>	Output Pin Capacitance	V <sub>OUT</sub> = 0V	12 pF
C <sub>IN</sub> <sup>1</sup>	Input Capacitance	V <sub>IN</sub> = 0V	6 pF

1. This parameter is measured only for initial qualification and after a design or process change that could affect this parameter.

**TABLE 4-7: RELIABILITY CHARACTERISTICS**

Symbol	Parameter	Minimum Specification	Units	Test Method
N <sub>END</sub> <sup>1</sup>	Endurance	100,000	Cycles	JEDEC Standard A117
	Status Register Write Cycle	100,000	Cycles	JEDEC Standard A117
T <sub>DR</sub> <sup>1</sup>	Data Retention	20	Years	JEDEC Standard A103
I <sub>LTH</sub> <sup>1</sup>	Latch Up	100 + I <sub>DD</sub>	mA	JEDEC Standard 78

1. This parameter is measured only for initial qualification and after a design or process change that could affect this parameter.

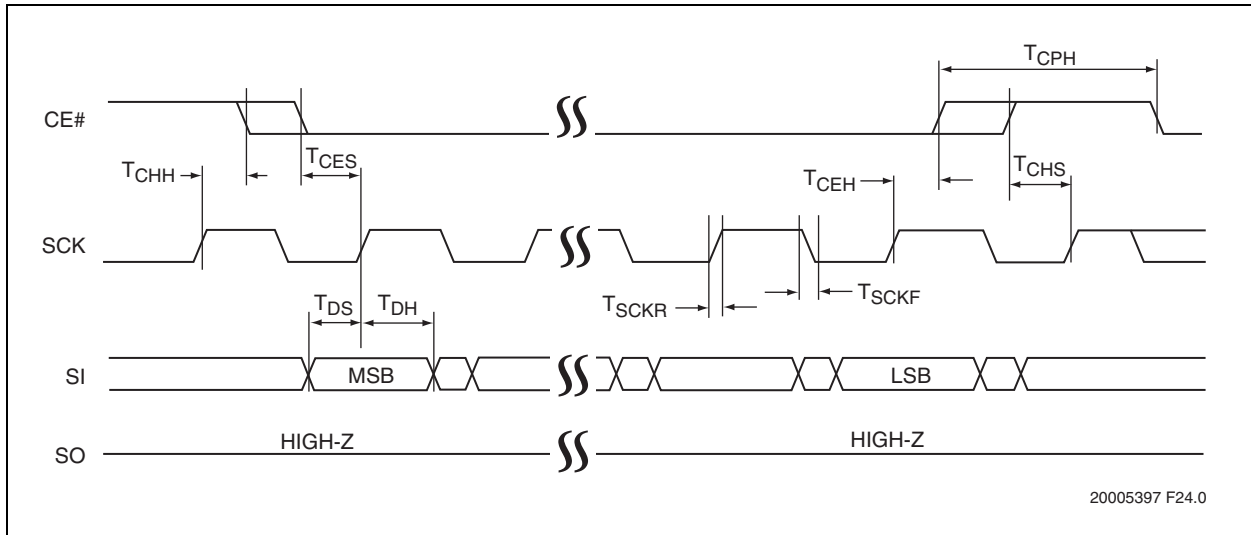
## 4.6 AC Characteristics

**TABLE 4-8: AC OPERATING CHARACTERISTICS**

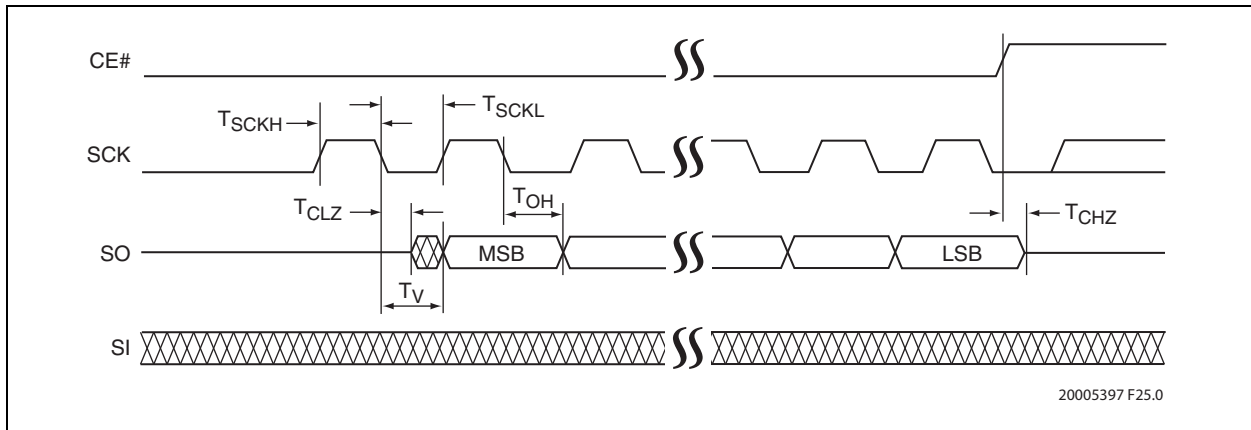
Symbol	Parameter	Limits - 25 MHz			Limits - 40 MHz			Units
		Min	Typical	Max	Min	Typical	Max	
F <sub>CLK</sub> <sup>1</sup>	Serial Clock Frequency			25			40	MHz
T <sub>SCKH</sub>	Serial Clock High Time	18			11.5			ns
T <sub>SCKL</sub>	Serial Clock Low Time	18			11.5			ns
T <sub>SCKR</sub>	Serial Clock Rise Time			5			5	ns
T <sub>SCKF</sub>	Serial Clock Fall Time			5			5	ns
T <sub>CES</sub> <sup>2</sup>	CE# Active Setup Time	8			8			ns
T <sub>CEH</sub> <sup>2</sup>	CE# Active Hold Time	8			8			ns
T <sub>CHS</sub> <sup>2</sup>	CE# Not Active Setup Time	8			8			ns
T <sub>CHH</sub> <sup>2</sup>	CE# Not Active Hold Time	8			8			ns
T <sub>CPH</sub>	CE# High Time	25			25			ns
T <sub>CHZ</sub>	CE# High to High-Z Output			8			8	ns
T <sub>CLZ</sub>	SCK Low to Low-Z Output	0			0			ns
T <sub>DS</sub>	Data In Setup Time	2			2			ns
T <sub>DH</sub>	Data In Hold Time	5			5			ns
T <sub>HLS</sub>	HOLD# Low Setup Time	5			5			ns
T <sub>HHS</sub>	HOLD# High Setup Time	5			5			ns
T <sub>HLH</sub>	HOLD# Low Hold Time	5			5			ns
T <sub>HHS</sub>	HOLD# High Hold Time	5			5			ns
T <sub>HZ</sub>	HOLD# Low to High-Z Output			9			9	ns
T <sub>LZ</sub>	HOLD# High to Low-Z Output			9			9	ns
T <sub>OH</sub>	Output Hold from SCK Change	1			1			ns
T <sub>V</sub>	Output Valid from SCK			11			11	ns
T <sub>WPS</sub>	WP# Setup Time	20			20			ns
T <sub>WPH</sub>	WP# Hold Time	20			20			ns
T <sub>WRSR</sub>	Status Register Write Time			10			15	ms
T <sub>DPD</sub>	CE# High to Deep Power-Down			3			3	μs
T <sub>SBR</sub>	Deep Power-Down (CE# High) to Standby Mode			3			3	μs
T <sub>SE</sub>	Sector Erase		40	150		40	150	ms
T <sub>BE</sub>	Block Erase		80	250		80	250	ms
T <sub>CE</sub>	Chip Erase		0.25	2		0.25	2	s
T <sub>PP</sub>	Page-Program (256 Byte)		4	5		4	5	ms

1. Maximum clock frequency for Read instruction, 03H, is 25 MHz
2. Relative to SCK

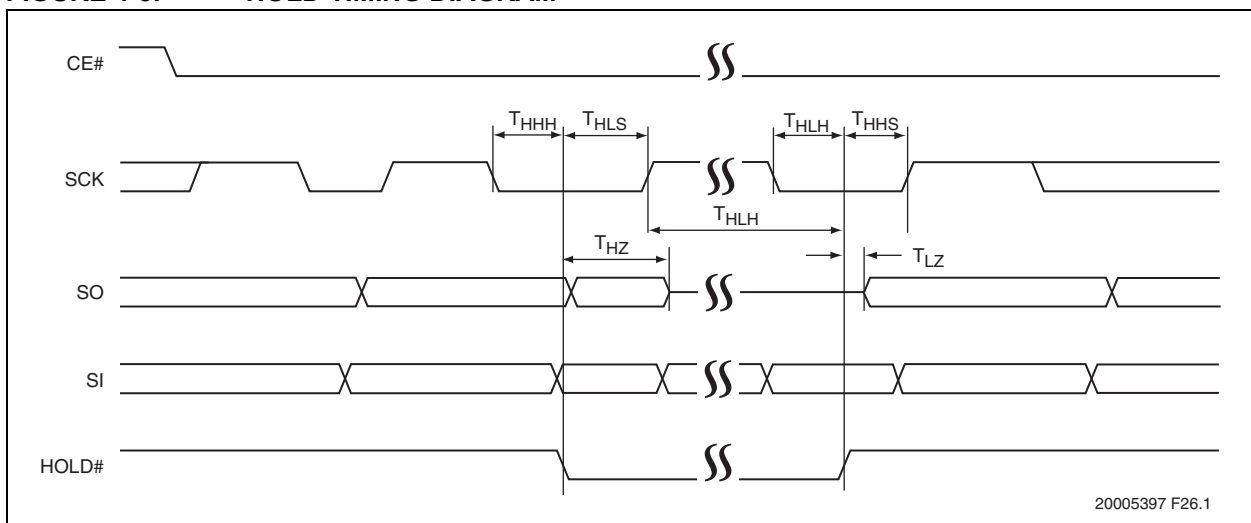
**FIGURE 4-3: SERIAL OUTPUT TIMING DIAGRAM**



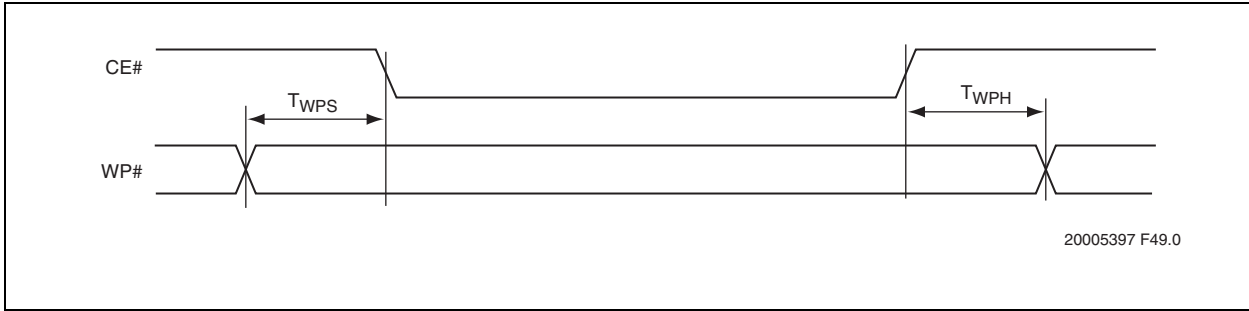
**FIGURE 4-4: SERIAL INPUT TIMING DIAGRAM**



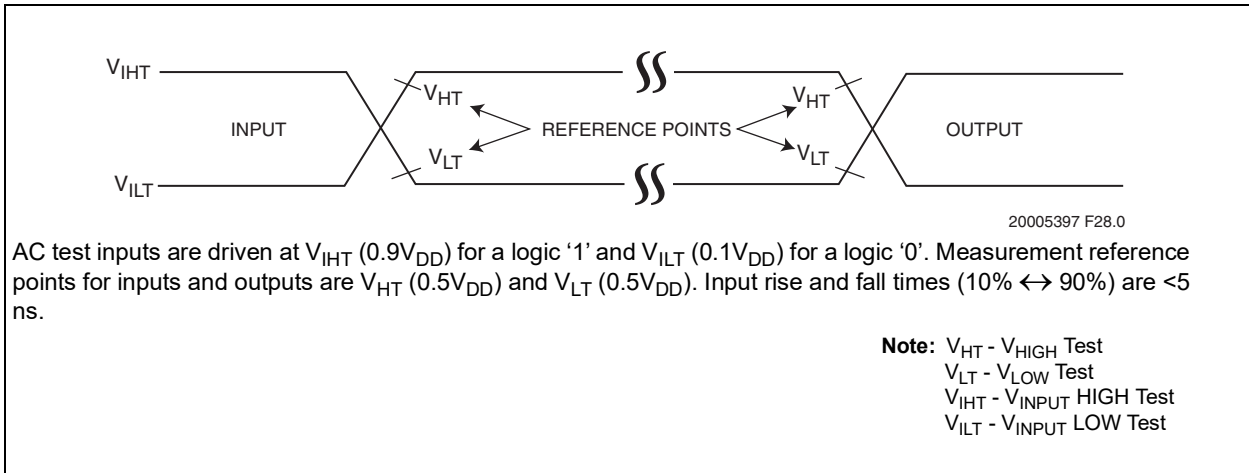
**FIGURE 4-5: HOLD TIMING DIAGRAM**



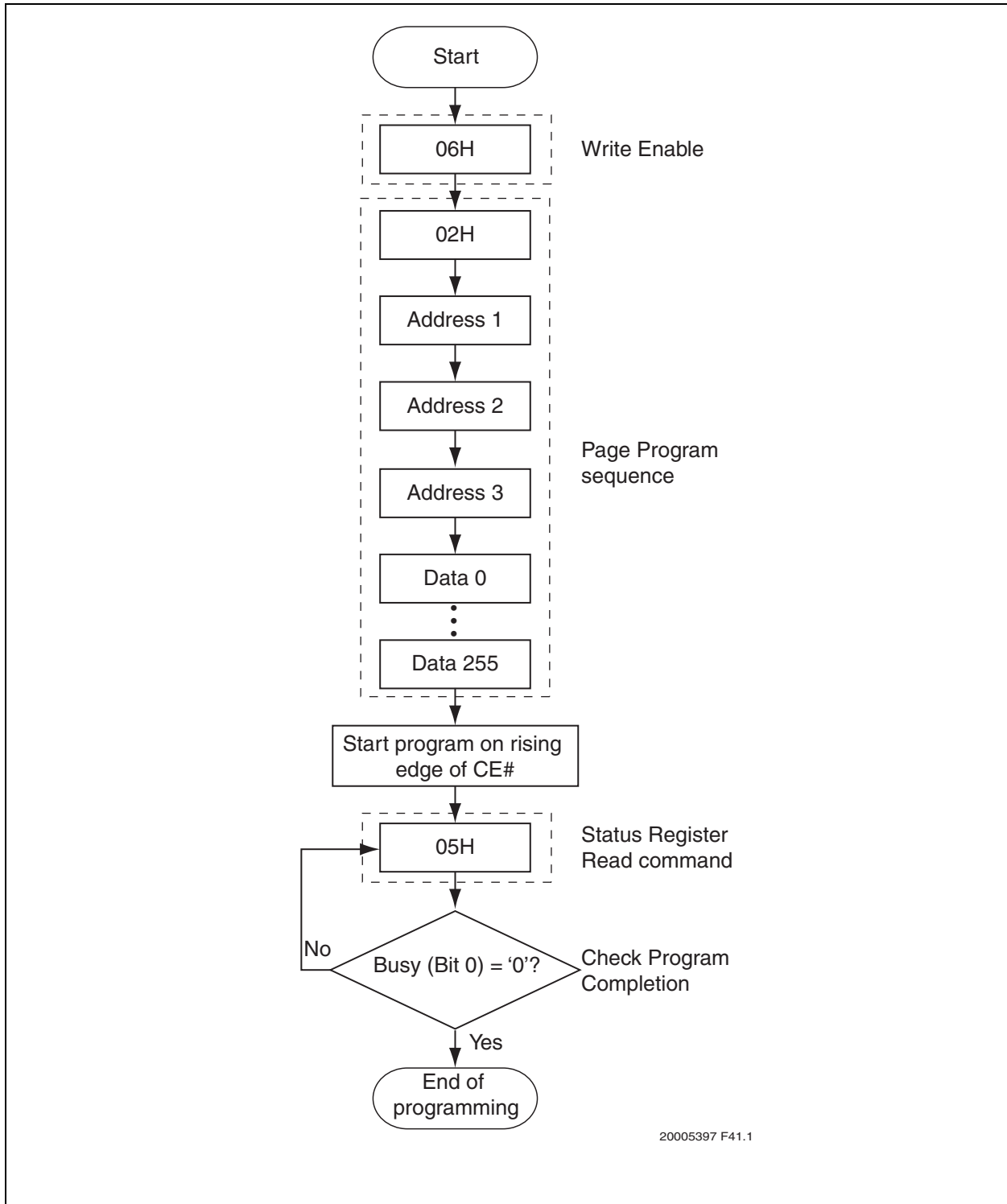
**FIGURE 4-6: STATUS REGISTER WRITE TIMING**



**FIGURE 4-7: AC INPUT/OUTPUT REFERENCE WAVEFORMS**

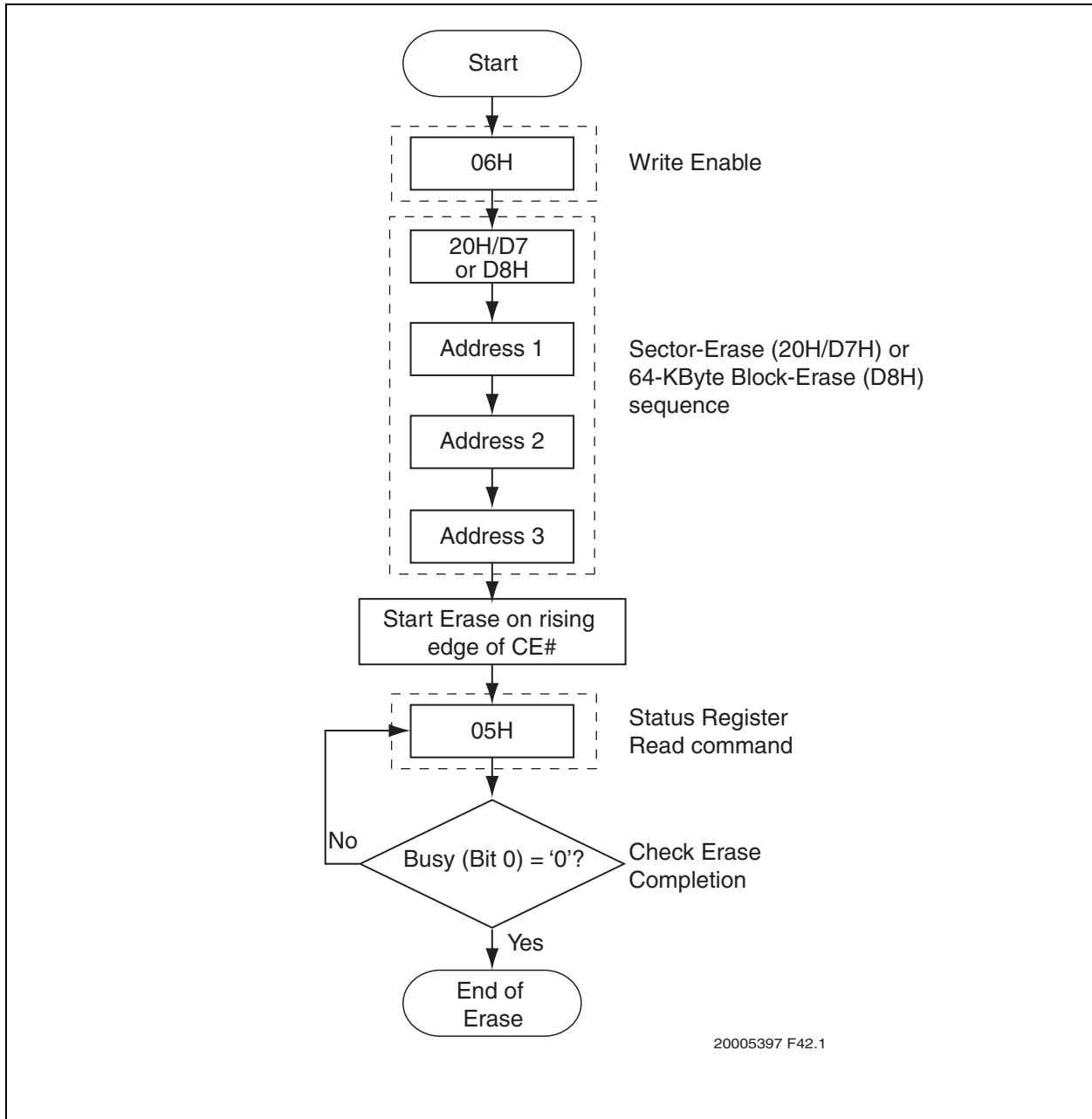


**FIGURE 4-8: PAGE-PROGRAM FLOW CHART**

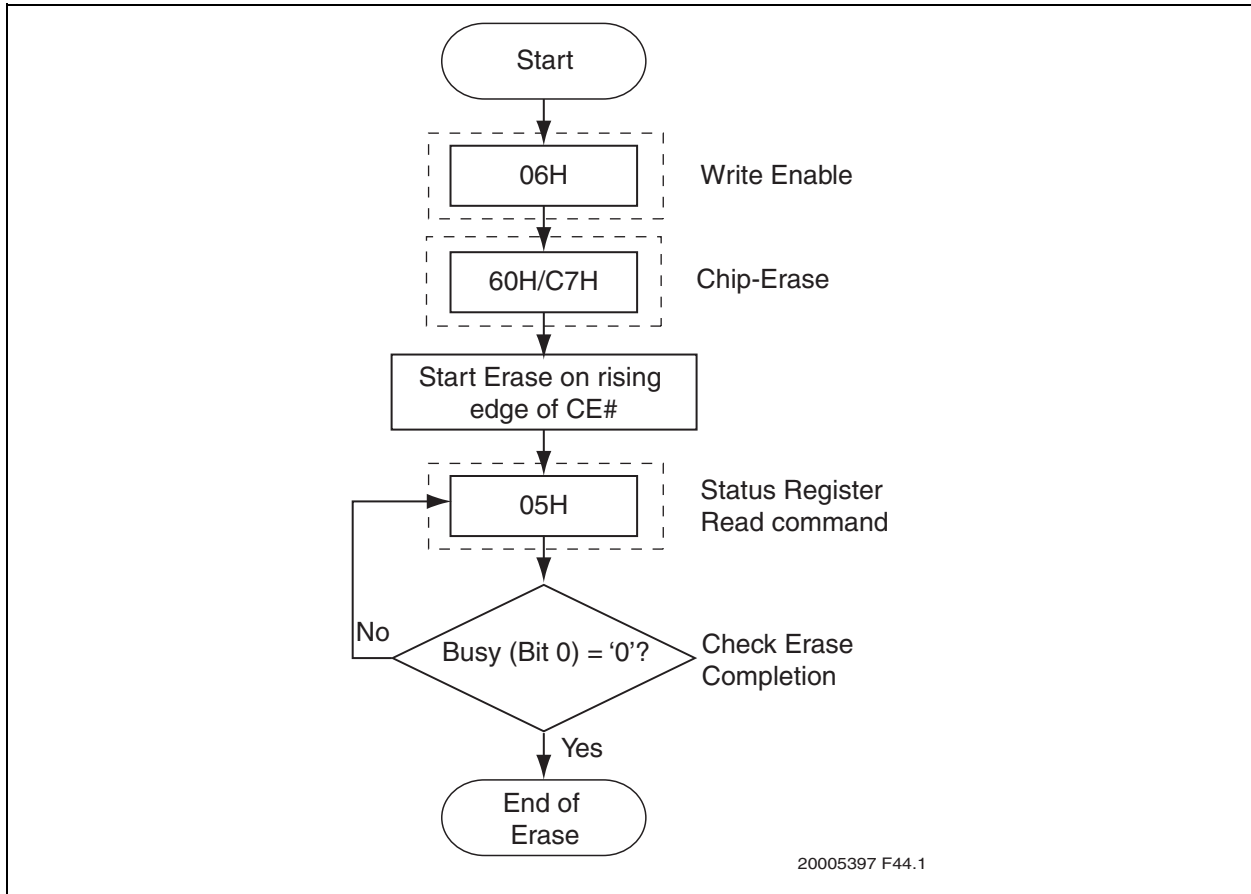


20005397 F41.1

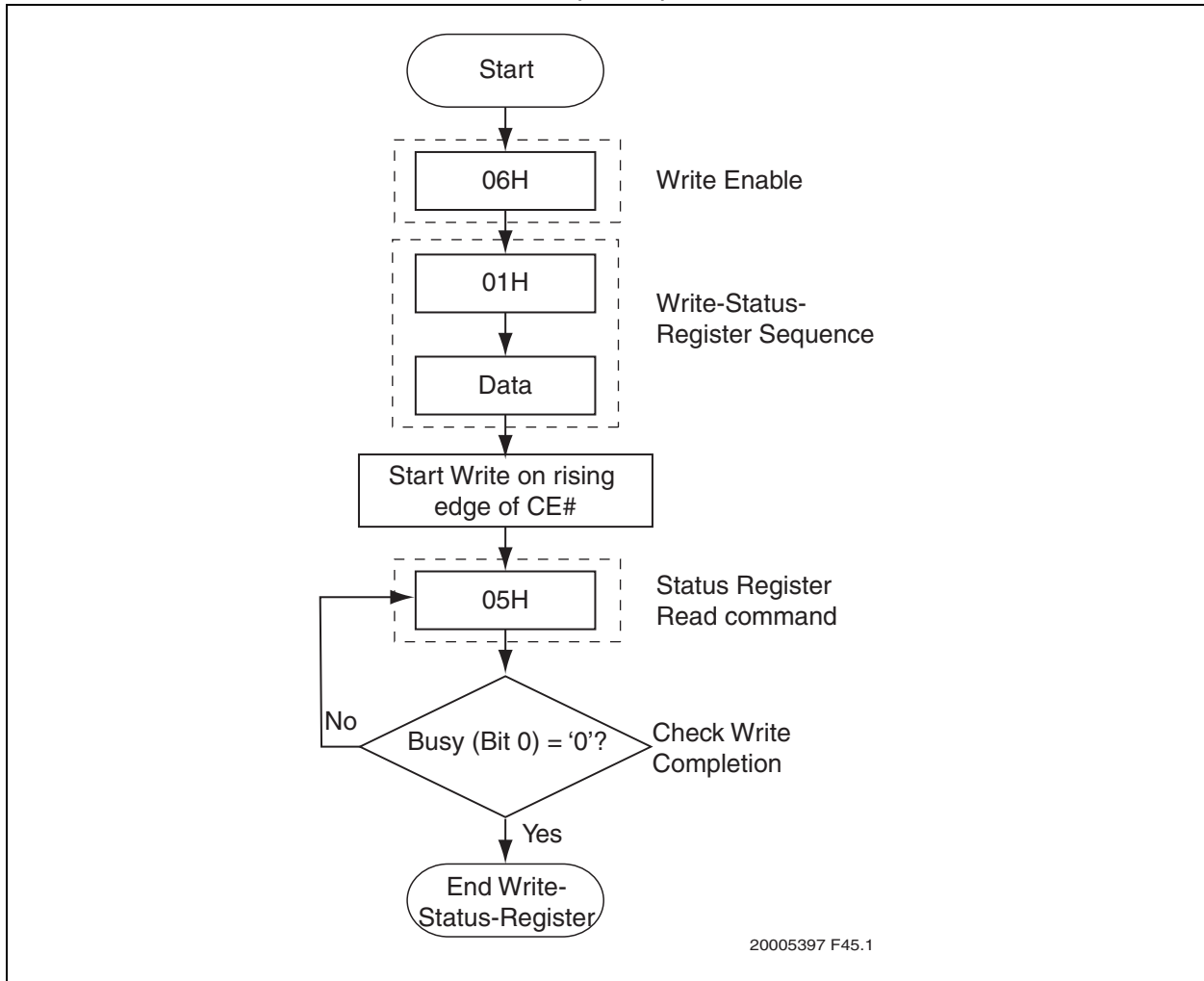
**FIGURE 4-9: SECTOR ERASE OR 64-KBYTE BLOCK ERASE FLOW CHART**



**FIGURE 4-10: CHIP ERASE FLOW CHART**



**FIGURE 4-11: WRITE-STATUS-REGISTER (WRSR) FLOW CHART**

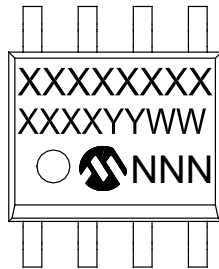




## 5.0 PACKAGING DIAGRAMS

### 5.1 Package Marking

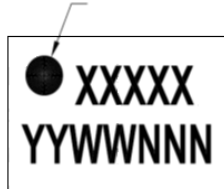
8-Lead SOIC (3.90 mm)



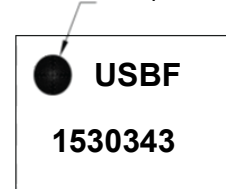
Example



8-Lead USON (2x3 mm)



Example



Part Number	Package Type	1st Line Marking Codes
USBF4100	SOIC	USBF
USBF4100	USON	USBF

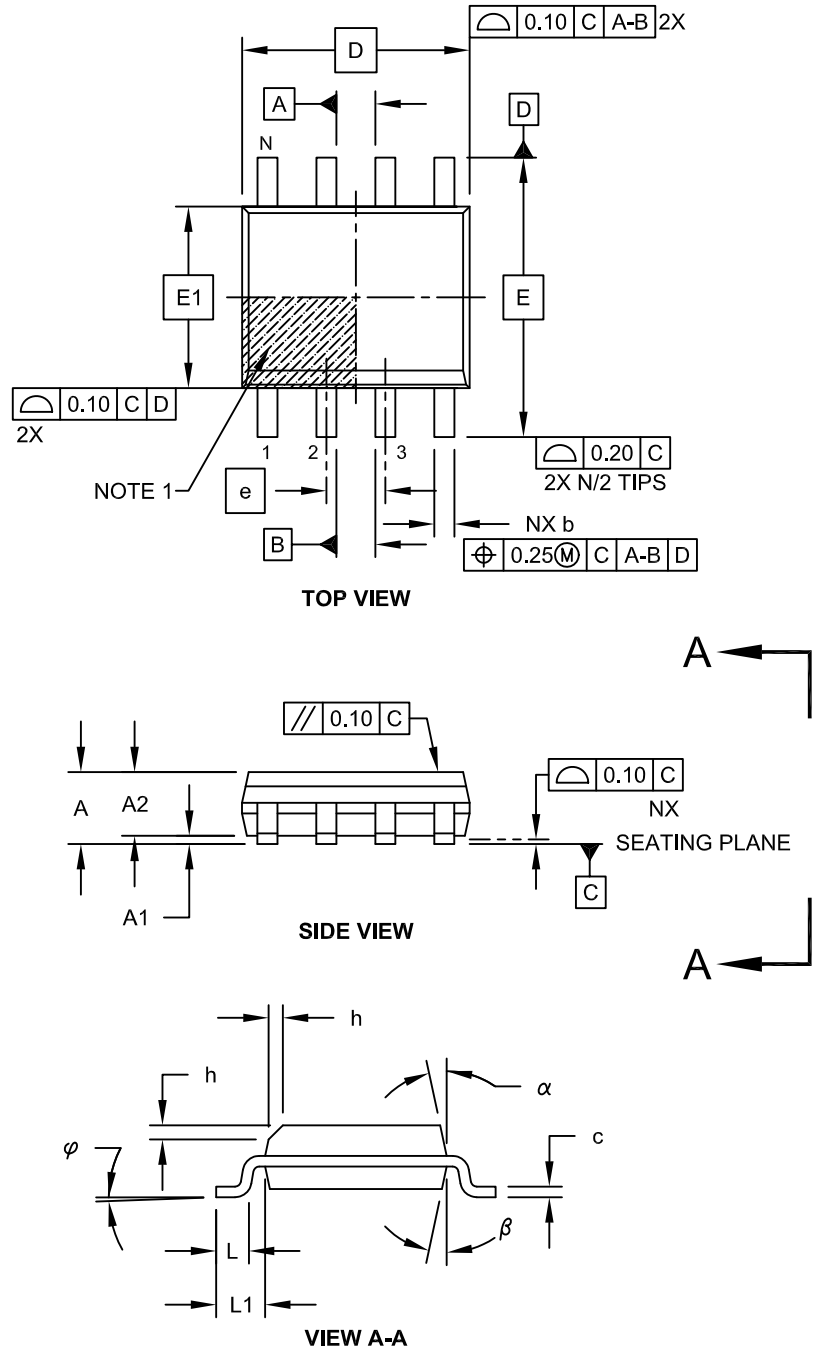
<b>Legend:</b>	XX...X	Part number or part number code
	Y	Year code (last digit of calendar year)
	YY	Year code (last 2 digits of calendar year)
	WW	Week code (week of January 1 is week '01')
	NNN	Alphanumeric traceability code (2 characters for small packages)
	(e3)	Pb-free JEDEC® designator for Matte Tin (Sn)

**Note:** For very small packages with no room for the Pb-free JEDEC® designator (e3), the marking will only appear on the outer carton or reel label.

**Note:** In the event the full Microchip part number cannot be marked on one line, it will be carried over to the next line, thus limiting the number of available characters for customer-specific information.

## 8-Lead Plastic Small Outline (SN) - Narrow, 3.90 mm Body [SOIC]

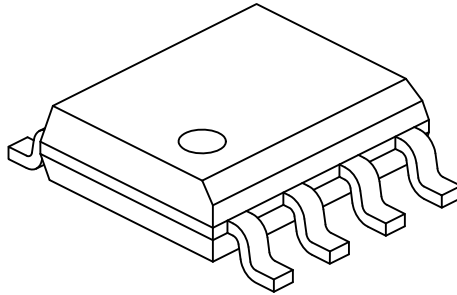
**Note:** For the most current package drawings, please see the Microchip Packaging Specification located at <http://www.microchip.com/packaging>



Microchip Technology Drawing No. C04-057C Sheet 1 of 2

## 8-Lead Plastic Small Outline (SN) - Narrow, 3.90 mm Body [SOIC]

**Note:** For the most current package drawings, please see the Microchip Packaging Specification located at <http://www.microchip.com/packaging>



Dimension Limits	Units	MILLIMETERS		
		MIN	NOM	MAX
Number of Pins	N	8		
Pitch	e	1.27 BSC		
Overall Height	A	-	-	1.75
Molded Package Thickness	A2	1.25	-	-
Standoff §	A1	0.10	-	0.25
Overall Width	E	6.00 BSC		
Molded Package Width	E1	3.90 BSC		
Overall Length	D	4.90 BSC		
Chamfer (Optional)	h	0.25	-	0.50
Foot Length	L	0.40	-	1.27
Footprint	L1	1.04 REF		
Foot Angle	$\varphi$	0°	-	8°
Lead Thickness	c	0.17	-	0.25
Lead Width	b	0.31	-	0.51
Mold Draft Angle Top	$\alpha$	5°	-	15°
Mold Draft Angle Bottom	$\beta$	5°	-	15°

**Notes:**

- Pin 1 visual index feature may vary, but must be located within the hatched area.
- § Significant Characteristic
- Dimensions D and E1 do not include mold flash or protrusions. Mold flash or protrusions shall not exceed 0.15mm per side.
- Dimensioning and tolerancing per ASME Y14.5M

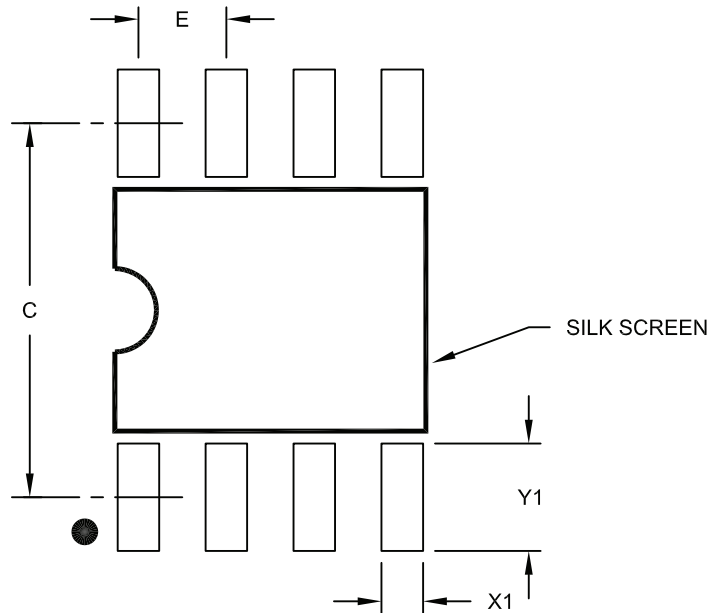
BSC: Basic Dimension. Theoretically exact value shown without tolerances.

REF: Reference Dimension, usually without tolerance, for information purposes only.

Microchip Technology Drawing No. C04-057C Sheet 2 of 2

## 8-Lead Plastic Small Outline (SN) – Narrow, 3.90 mm Body [SOIC]

**Note:** For the most current package drawings, please see the Microchip Packaging Specification located at <http://www.microchip.com/packaging>



RECOMMENDED LAND PATTERN

Dimension Limits	Units	MILLIMETERS		
		MIN	NOM	MAX
Contact Pitch	E	1.27 BSC		
Contact Pad Spacing	C		5.40	
Contact Pad Width (X8)	X1			0.60
Contact Pad Length (X8)	Y1			1.55

Notes:

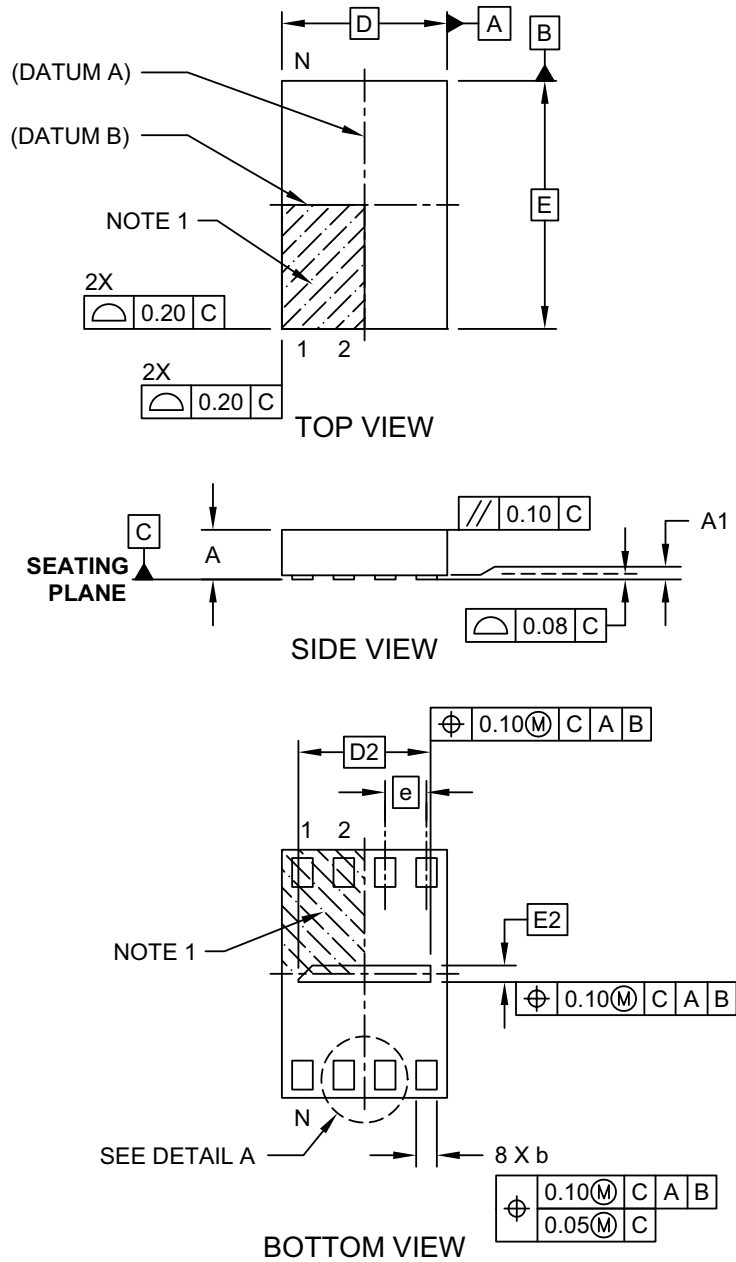
1. Dimensioning and tolerancing per ASME Y14.5M

BSC: Basic Dimension. Theoretically exact value shown without tolerances.

Microchip Technology Drawing No. C04-2057A

## 8-Lead Plastic Ultra Thin Small Outline No Lead Package (NP) - 2x3 mm Body [USON] [Also called UDFN]

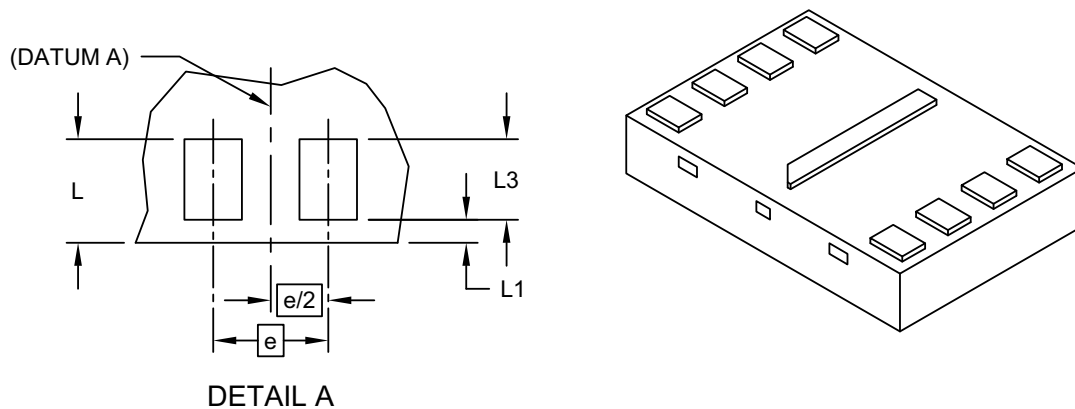
**Note:** For the most current package drawings, please see the Microchip Packaging Specification located at <http://www.microchip.com/packaging>



Microchip Technology Drawing C04-203C [NP] Sheet 1 of 2

## 8-Lead Plastic Ultra Thin Small Outline No Lead Package (NP) - 2x3 mm Body [USON] [Also called UDFN]

**Note:** For the most current package drawings, please see the Microchip Packaging Specification located at <http://www.microchip.com/packaging>



Units		MILLIMETERS		
Dimension Limits		MIN	NOM	MAX
Number of Terminals	N	8		
Pitch	e	0.50 BSC		
Overall Height	A	0.45	0.55	0.60
Standoff	A1	0.00	0.02	0.05
Overall Width	D	2.00 BSC		
Exposed Pad Width	D2	1.50	1.60	1.70
Overall Length	E	3.00 BSC		
Exposed Pad Length	E2	0.10	0.20	0.30
Terminal Width	b	0.20	0.25	0.30
Package Edge to Terminal Edge	L	0.40	0.45	0.50
Package Edge to Terminal Edge	L1	—	0.10	—
Terminal Length	L3	0.30	0.35	0.40

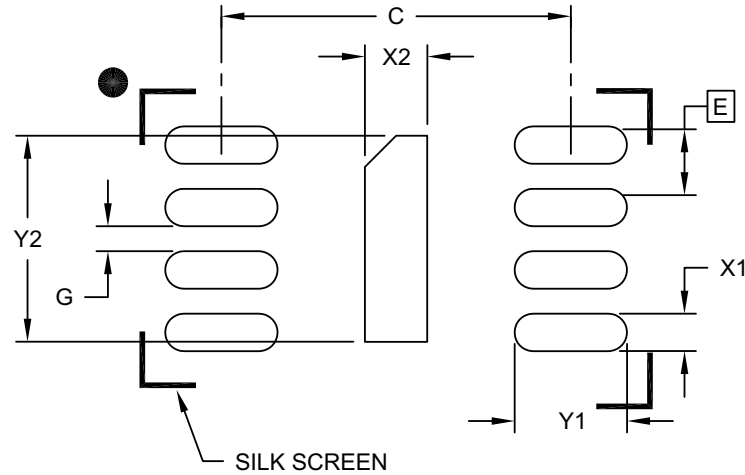
**Notes:**

- Pin 1 visual index feature may vary, but must be located within the hatched area.
- Package is saw singulated
- Dimensioning and tolerancing per ASME Y14.5M
  - BSC: Basic Dimension. Theoretically exact value shown without tolerances.
  - REF: Reference Dimension, usually without tolerance, for information purposes only.

Microchip Technology Drawing C04-203C [NP] Sheet 2 of 2

## 8-Lead Plastic Ultra Thin Small Outline No Lead Package (NP) - 2x3 mm Body [USON] [Also called UDFN]

**Note:** For the most current package drawings, please see the Microchip Packaging Specification located at <http://www.microchip.com/packaging>



### RECOMMENDED LAND PATTERN

Dimension Limits	Units	MILLIMETERS		
		MIN	NOM	MAX
Terminal Pitch	E	0.50 BSC		
Optional Center Pad Width	X2			0.25
Optional Center Pad Length	Y2			1.65
Terminal Pad Spacing	C		2.80	
Terminal Pad Width (X8)	X1			0.30
Terminal Pad Length (X8)	Y1			0.90
Minimum Between Terminal Pads	G	0.20		

**Notes:**

1. Dimensioning and tolerancing per ASME Y14.5M

BSC: Basic Dimension. Theoretically exact value shown without tolerances.

Microchip Technology Drawing C04-2203B [NP]

## APPENDIX A: REVISION HISTORY

### April 2020

- Added automotive grade 1/extended temperature.

### June 2018

- Initial release.



## 6.0 PRODUCT IDENTIFICATION SYSTEM

To order or obtain information, e.g., on pricing or delivery, refer to the factory or the listed sales office.

<u>PART NO.</u>		<u>X</u>	<u>XX</u>	<u>XX</u>	<u>XXX</u>
Device	Tape/Reel Indicator	Temperature	Package	Grade	
Device:	USBF4100	= USB Firmware Memory			
Tape and Reel Flag:	T	= Tape and Reel			
Temperature:	I	= -40°C to +85°C			
	V	= -40°C to +105°C			
	E	= -40°C to +125°C			
Package:	SN	= SOIC (3.90 mm Body), 8-lead			
	NP	= USON (2x3 mm Body), 8-contact			
Grade:	VAO	= Automotive Grade			
					<b>Valid Combinations:</b> USBF4100-I/SNVAO USBF4100T-I/SNVAO USBF4100T-I/NPVAO USBF4100-V/SNVAO USBF4100T-V/SNVAO USBF4100T-V/NPVAO USBF4100-E/SNVAO USBF4100T-E/SNVAO

## THE MICROCHIP WEBSITE

Microchip provides online support via our WWW site at [www.microchip.com](http://www.microchip.com). This website is used as a means to make files and information easily available to customers. Accessible by using your favorite Internet browser, the website contains the following information:

- **Product Support** – Data sheets and errata, application notes and sample programs, design resources, user's guides and hardware support documents, latest software releases and archived software
- **General Technical Support** – Frequently Asked Questions (FAQ), technical support requests, online discussion groups, Microchip consultant program member listing
- **Business of Microchip** – Product selector and ordering guides, latest Microchip press releases, listing of seminars and events, listings of Microchip sales offices, distributors and factory representatives

## CUSTOMER CHANGE NOTIFICATION SERVICE

Microchip's customer notification service helps keep customers current on Microchip products. Subscribers will receive e-mail notification whenever there are changes, updates, revisions or errata related to a specified product family or development tool of interest.

To register, access the Microchip website at [www.microchip.com](http://www.microchip.com). Under "Support", click on "Customer Change Notification" and follow the registration instructions.

## CUSTOMER SUPPORT

Users of Microchip products can receive assistance through several channels:

- Distributor or Representative
- Local Sales Office
- Field Application Engineer (FAE)
- Technical Support

Customers should contact their distributor, representative or Field Application Engineer (FAE) for support. Local sales offices are also available to help customers. A listing of sales offices and locations is included in the back of this document.

**Technical support is available through the website at: <http://microchip.com/support>**

---

**Note the following details of the code protection feature on Microchip devices:**

- Microchip products meet the specification contained in their particular Microchip Data Sheet.
- Microchip believes that its family of products is one of the most secure families of its kind on the market today, when used in the intended manner and under normal conditions.
- There are dishonest and possibly illegal methods used to breach the code protection feature. All of these methods, to our knowledge, require using the Microchip products in a manner outside the operating specifications contained in Microchip's Data Sheets. Most likely, the person doing so is engaged in theft of intellectual property.
- Microchip is willing to work with the customer who is concerned about the integrity of their code.
- Neither Microchip nor any other semiconductor manufacturer can guarantee the security of their code. Code protection does not mean that we are guaranteeing the product as “unbreakable.”

Code protection is constantly evolving. We at Microchip are committed to continuously improving the code protection features of our products. Attempts to break Microchip's code protection feature may be a violation of the Digital Millennium Copyright Act. If such acts allow unauthorized access to your software or other copyrighted work, you may have a right to sue for relief under that Act.

---

Information contained in this publication regarding device applications and the like is provided only for your convenience and may be superseded by updates. It is your responsibility to ensure that your application meets with your specifications. MICROCHIP MAKES NO REPRESENTATIONS OR WARRANTIES OF ANY KIND WHETHER EXPRESS OR IMPLIED, WRITTEN OR ORAL, STATUTORY OR OTHERWISE, RELATED TO THE INFORMATION, INCLUDING BUT NOT LIMITED TO ITS CONDITION, QUALITY, PERFORMANCE, MERCHANTABILITY OR FITNESS FOR PURPOSE. Microchip disclaims all liability arising from this information and its use. Use of Microchip devices in life support and/or safety applications is entirely at the buyer's risk, and the buyer agrees to defend, indemnify and hold harmless Microchip from any and all damages, claims, suits, or expenses resulting from such use. No licenses are conveyed, implicitly or otherwise, under any Microchip intellectual property rights unless otherwise stated.

### Trademarks

The Microchip name and logo, the Microchip logo, Adaptec, AnyRate, AVR, AVR logo, AVR Freaks, BesTime, BitCloud, chipKIT, chipKIT logo, CryptoMemory, CryptoRF, dsPIC, FlashFlex, flexPWR, HELDO, IGLoo, JukeBlox, KeeLoq, Klear, LANCheck, LinkMD, maXStylus, maXTouch, MediaLB, megaAVR, Microsemi, Microsemi logo, MOST, MOST logo, MPLAB, OptoLyzer, PackeTime, PIC, picoPower, PICSTART, PIC32 logo, PolarFire, Prochip Designer, QTouch, SAM-BA, SenGenuity, SpyNIC, SST, SST Logo, SuperFlash, Symmetricom, SyncServer, Tachyon, TempTrackr, TimeSource, tinyAVR, UNI/O, Vectron, and XMEGA are registered trademarks of Microchip Technology Incorporated in the U.S.A. and other countries.

APT, ClockWorks, The Embedded Control Solutions Company, EtherSynch, FlashTec, Hyper Speed Control, HyperLight Load, IntelliMOS, Libero, motorBench, mTouch, Powermite 3, Precision Edge, ProASIC, ProASIC Plus, ProASIC Plus logo, Quiet-Wire, SmartFusion, SyncWorld, Temux, TimeCesium, TimeHub, TimePictra, TimeProvider, Vite, WinPath, and ZL are registered trademarks of Microchip Technology Incorporated in the U.S.A.

Adjacent Key Suppression, AKS, Analog-for-the-Digital Age, Any Capacitor, AnyIn, AnyOut, BlueSky, BodyCom, CodeGuard, CryptoAuthentication, CryptoAutomotive, CryptoCompanion, CryptoController, dsPICDEM, dsPICDEM.net, Dynamic Average Matching, DAM, ECAN, EtherGREEN, In-Circuit Serial Programming, ICSP, INICnet, Inter-Chip Connectivity, JitterBlocker, KlearNet, KlearNet logo, memBrain, Mindi, MiWi, MPASM, MPF, MPLAB Certified logo, MPLIB, MPLINK, MultiTRAK, NetDetach, Omniscient Code Generation, PICDEM, PICDEM.net, PICkit, PICtail, PowerSmart, PureSilicon, QMatrix, REAL ICE, Ripple Blocker, SAM-ICE, Serial Quad I/O, SMART-I.S., SQI, SuperSwitcher, SuperSwitcher II, Total Endurance, TSHARC, USBCheck, VariSense, ViewSpan, WiperLock, Wireless DNA, and ZENA are trademarks of Microchip Technology Incorporated in the U.S.A. and other countries.

SQTP is a service mark of Microchip Technology Incorporated in the U.S.A.

The Adaptec logo, Frequency on Demand, Silicon Storage Technology, and Symmcom are registered trademarks of Microchip Technology Inc. in other countries.

GestIC is a registered trademark of Microchip Technology Germany II GmbH & Co. KG, a subsidiary of Microchip Technology Inc., in other countries.

All other trademarks mentioned herein are property of their respective companies.

© 2018-2020, Microchip Technology Incorporated, All Rights Reserved.

ISBN: 978-1-5224-5942-2

For information regarding Microchip's Quality Management Systems, please visit [www.microchip.com/quality](http://www.microchip.com/quality).



# MICROCHIP

## Worldwide Sales and Service

### AMERICAS

**Corporate Office**  
2355 West Chandler Blvd.  
Chandler, AZ 85224-6199  
Tel: 480-792-7200  
Fax: 480-792-7277  
Technical Support:  
<http://www.microchip.com/support>  
Web Address:  
[www.microchip.com](http://www.microchip.com)

**Atlanta**  
Duluth, GA  
Tel: 678-957-9614  
Fax: 678-957-1455

**Austin, TX**  
Tel: 512-257-3370

**Boston**  
Westborough, MA  
Tel: 774-760-0087  
Fax: 774-760-0088

**Chicago**  
Itasca, IL  
Tel: 630-285-0071  
Fax: 630-285-0075

**Dallas**  
Addison, TX  
Tel: 972-818-7423  
Fax: 972-818-2924

**Detroit**  
Novi, MI  
Tel: 248-848-4000

**Houston, TX**  
Tel: 281-894-5983

**Indianapolis**  
Noblesville, IN  
Tel: 317-773-8323  
Fax: 317-773-5453  
Tel: 317-536-2380

**Los Angeles**  
Mission Viejo, CA  
Tel: 949-462-9523  
Fax: 949-462-9608  
Tel: 951-273-7800

**Raleigh, NC**  
Tel: 919-844-7510

**New York, NY**  
Tel: 631-435-6000

**San Jose, CA**  
Tel: 408-735-9110  
Tel: 408-436-4270

**Canada - Toronto**  
Tel: 905-695-1980  
Fax: 905-695-2078

### ASIA/PACIFIC

**Australia - Sydney**  
Tel: 61-2-9868-6733

**China - Beijing**  
Tel: 86-10-8569-7000

**China - Chengdu**  
Tel: 86-28-8665-5511

**China - Chongqing**  
Tel: 86-23-8980-9588

**China - Dongguan**  
Tel: 86-769-8702-9880

**China - Guangzhou**  
Tel: 86-20-8755-8029

**China - Hangzhou**  
Tel: 86-571-8792-8115

**China - Hong Kong SAR**  
Tel: 852-2943-5100

**China - Nanjing**  
Tel: 86-25-8473-2460

**China - Qingdao**  
Tel: 86-532-8502-7355

**China - Shanghai**  
Tel: 86-21-3326-8000

**China - Shenyang**  
Tel: 86-24-2334-2829

**China - Shenzhen**  
Tel: 86-755-8864-2200

**China - Suzhou**  
Tel: 86-186-6233-1526

**China - Wuhan**  
Tel: 86-27-5980-5300

**China - Xian**  
Tel: 86-29-8833-7252

**China - Xiamen**  
Tel: 86-592-2388138

**China - Zhuhai**  
Tel: 86-756-3210040

### ASIA/PACIFIC

**India - Bangalore**  
Tel: 91-80-3090-4444

**India - New Delhi**  
Tel: 91-11-4160-8631

**India - Pune**  
Tel: 91-20-4121-0141

**Japan - Osaka**  
Tel: 81-6-6152-7160

**Japan - Tokyo**  
Tel: 81-3-6880-3770

**Korea - Daegu**  
Tel: 82-53-744-4301

**Korea - Seoul**  
Tel: 82-2-554-7200

**Malaysia - Kuala Lumpur**  
Tel: 60-3-7651-7906

**Malaysia - Penang**  
Tel: 60-4-227-8870

**Philippines - Manila**  
Tel: 63-2-634-9065

**Singapore**  
Tel: 65-6334-8870

**Taiwan - Hsin Chu**  
Tel: 886-3-577-8366

**Taiwan - Kaohsiung**  
Tel: 886-7-213-7830

**Taiwan - Taipei**  
Tel: 886-2-2508-8600

**Thailand - Bangkok**  
Tel: 66-2-694-1351

**Vietnam - Ho Chi Minh**  
Tel: 84-28-5448-2100

### EUROPE

**Austria - Wels**  
Tel: 43-7242-2244-39  
Fax: 43-7242-2244-393

**Denmark - Copenhagen**  
Tel: 45-4485-5910  
Fax: 45-4485-2829

**Finland - Espoo**  
Tel: 358-9-4520-820

**France - Paris**  
Tel: 33-1-69-53-63-20  
Fax: 33-1-69-30-90-79

**Germany - Garching**  
Tel: 49-8931-9700

**Germany - Haan**  
Tel: 49-2129-3766400

**Germany - Heilbronn**  
Tel: 49-7131-72400

**Germany - Karlsruhe**  
Tel: 49-721-625370

**Germany - Munich**  
Tel: 49-89-627-144-0  
Fax: 49-89-627-144-44

**Germany - Rosenheim**  
Tel: 49-8031-354-560

**Israel - Ra'anana**  
Tel: 972-9-744-7705

**Italy - Milan**  
Tel: 39-0331-742611  
Fax: 39-0331-466781

**Italy - Padova**  
Tel: 39-049-7625286

**Netherlands - Drunen**  
Tel: 31-416-690399  
Fax: 31-416-690340

**Norway - Trondheim**  
Tel: 47-7288-4388

**Poland - Warsaw**  
Tel: 48-22-3325737

**Romania - Bucharest**  
Tel: 40-21-407-87-50

**Spain - Madrid**  
Tel: 34-91-708-08-90  
Fax: 34-91-708-08-91

**Sweden - Gothenberg**  
Tel: 46-31-704-60-40

**Sweden - Stockholm**  
Tel: 46-8-5090-4654

**UK - Wokingham**  
Tel: 44-118-921-5800  
Fax: 44-118-921-5820