



5	6
REV.	ECN NO OR DESCRIPTION
REVISED	DATE

NOTES:

SPECIFICATION:

- CURRENT RATING: 5A FOR VBUS PIN; 1.25A FOR VCONN PIN.
- DIELECTRIC WITHSTANDING VOLTAGE: 100V AC R.M.S.
- TEMPERATURE RANGE: -30 °C ~ 85 °C
- CONTACT RESISTANCE: 40mΩ Max
- INSULATION RESISTANCE: 100 MΩ Min.
- INSERTION FORCE : 5N~20N
- UNMATING FORCE: 8N~20N
- DURABILITY: 10,000 CYCLES
- SALT SPRAY: 24H
- PLATING:
TERMINAL CONTACT: GOLD PLATING ALL OVER
50U" NICKEL AND 80U" TIN ALL OVER
50U" NICKEL ON SOLDER AREA.
SHELL:50U" NICKEL ALL OVER.
- "▼" SHOWS QIP INSPECTION ITEM.

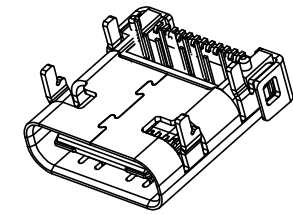

PIN ASSIGNMENTS:

A1	GND	B12	GND
A2	SSTXP1	B11	SSRXP1
A3	SSTXN1	B10	SSRXN1
A4	VBUS	B9	VBUS
A5	CC1	B8	SBU2
A6	DP1	B7	DN2
A7	DN1	B6	DP2
A8	SBU1	B5	CC2
A9	VBUS	B4	VBUS
A10	SSRXN2	B3	SSTXN2
A11	SSRXP2	B2	SSTXP2
A12	GND	B1	GND
PIN	SIGNAL NAME	PIN	SIGNAL NAME

TABLE A

P / N	DIM A
MC-208C	1.25

4	SHELL	STAINLESS STEEL	Ni Plated	1PCS
3	SPRING	STAINLESS STEEL	---	1PCS
2	CONTACT	COPPER ALLOY	Au on Contact area	2SET
1	HOUSING	HIGH TEMPERATURE PLASTIC	BLACK	1PCS
NO.	DESCRIPTION	MATERIAL	REMARKS	QTY

UNLESS OTHERWISE SPECIFIED TOLERANCES

DECIMALS: X. :±0.20 X.X :±0.15 X.XX :±0.10

ANGLES: X° :±2° X.X° :±1°

TITLE: DWN xiong MC-208C

CHKD: lee SCALE: 1:1 UNIT: mm

APVD: wang SIZE: A4 SHEET: 10F 1 REV: A4

CUSTOMER COPY

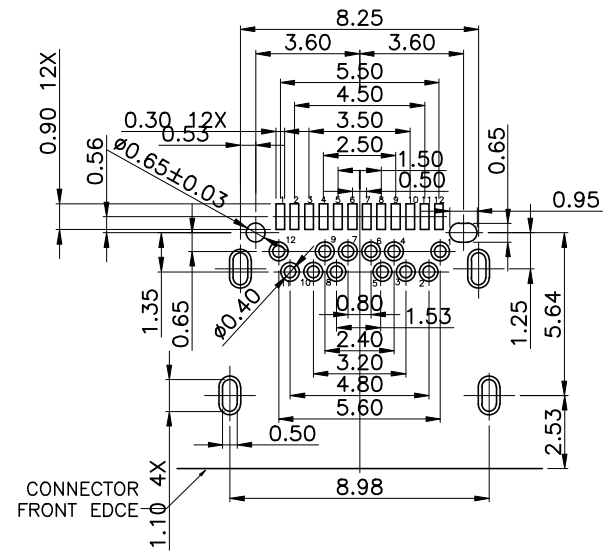
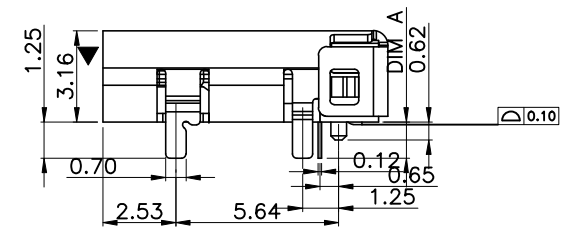
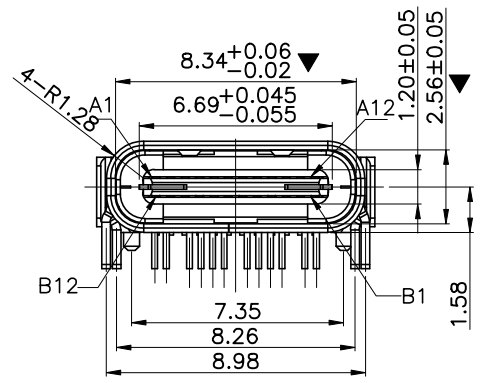
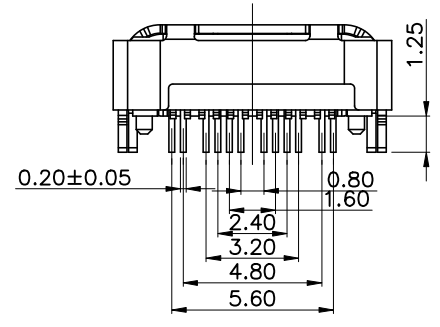
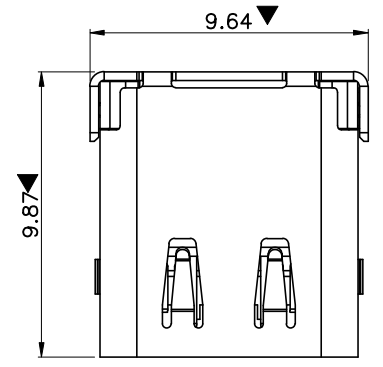

RECOMMENDED P.C.B. LAYOUT
TOLERANCE UNSPECIFIED ±0.05mm

A
B
C
D

A
B
C
D